

الإمارة الإسلامية بأفغانستان

مكتب الخدمات

قيادة المعسكرات والجبهات

موسوعة الجهاد

الجزء الثاني

الطبعة الالكترونية الأولى

١٤٢٣هـ

كلمة لا بد منها

.(:)

()

:)

: (:)

": (:)

()." :

:
()(. :)

—

. / : 1

— — () 2

()

.

.

:

...

:

...

- -

.. ..

...

.

.

بسم الله الرحمن الرحيم

الإهداء الأول

كلمة حق ودمعة وفاء ...

إلى الأخ الحبيب وشيخنا الفاضل **عبد الله عزام** - رحمه الله تعالى -

الذي أحيا روح الجهاد في نفوس الشباب بكلماته وكتاباته.

الذي ربى النفوس على الجهاد بصدقه وإخلاصه.

الذي قدم ما تعجز أي جماعة عن عمله.

الذي قدم الجهاد الأفغاني الاسلامي للعالم.

الذي صبر ولم يترك الميدان رغم الحجج ورغم الضغوط ورغم الايذاء من معظم الناس إلا من والديه رحمهم الله.

الذي قدم حياته وحياة ثمرتين من فؤاده من أجل الجهاد.

إلى الله هذا العمل ثم إليك.

أسأل الله أن يجعله في ميزان حسناتك وكل من يستفيد منه إلى يوم القيامة ثم إلى أرواح الشهداء المسلمين في أفغانستان وغيرها.

مكتب الخدمات

قيادة المعسكرات والجبهات

بسم الله الرحمن الرحيم

الإهداء الثاني

إلى الأخ الحبيب **أبي عبد الله - أسامة بن لادن - ...**

الذي شارك الشهيد عبد الله عزام في جهاده، وفي تأسيسه لمكتب الخدمات.

الذي جاهد في أفغانستان بنفسه وما يملك.

الذي ما زال يجاهد ويحرض على الجهاد حتى الآن.

الذي ظلمه في جهاده معظم الملتزمين بالاسلام أفراداً وجماعات.

أسأل الله أن يصبرك ويجزيك عن الاسلام والمسلمين والجهاد والمجاهدين كل خير.

مكتب الخدمات

قيادة المعسكرات والجبهات

بسم الله الرحمن الرحيم

الإهداء الثالث

إلى **قادة الجهاد الأفغاني الاسلامي** ...

الذين أعادوا للمسلمين روح الجهاد بعد أن خمدت.

الذين قدموا للمجاهدين المسلمين في كل مكان طاقاتهم والذي تعتبر هذه الموسوعة إحدى الطاقات التي قدموها.

الذين وضعوا بجهادهم أول لبنة في صرح خلافة إسلامية عادلة، أسأل الله أن يجعل في حسناتهم كل من استفاد من هذا الجهاد في إقامة صرح خلافة المسلمين.

مكتب الخدمات

قيادة المعسكرات والجبهات

بسم الله الرحمن الرحيم

الإهداء الرابع

إلى **الإخوة الذين ساهموا في إخراج هذه الموسوعة** والذين لا يعلمهم إلا الله ...

نسأل الله أن يجعل ذلك في ميزان حسناتكم يوم القيامة؛ وأن يجزي خيراً كل من شارك فيها سواءً بالترجمة أو الرسم أو الطباعة أو الكتابة أو المراجعة أو الإعداد وجمع المادة - أو من ساهم بمعلومة بالتجربة أو التصوير أو من ارسل أجهزة الكمبيوتر أو أمدنا بكتاب أو مذكرة - أو غير ذلك مما نكون قد نسيناه. وأن يجعل ذلك في ميزان حسناتكم يوم القيامة.

مكتب الخدمات

قيادة المعسكرات والجبهات

الجزء الثاني

الدورات العملية

:

Smothering

)

.(...

.()

()

)

(

.

.

.

:

.

.

.

:

▪

▪

()

.

.

()

()

() :

()

:

()

(CO₂) :

(CO)

(C₂H₄)

()

(Cupros Chloride)

()

.()

:

)

.(

(

)

(

)

:

()	
()	

()

:

)

:

(

()

:

:()

▪

:

▪

▪

()

(antenna)

Filter Plans

)

(

()

(Tape).

()

)

.(

()

)

(

(- -)

.

:

.



.

.

.()

()

.

The war quit

()

()

.()

(Hunga – Munga)

(war quit)

(Lawn dart)

(

(,)

()

()

()

()

(

()

“ ”

.()

(

(

(

(

()

()

(

()

(

(

(

()

(

()

(

(

) (potasium ferro chloride)

(

(

(

:

	Tepp
	Disyston
	Guthion
	EPN
	Syston
	OMPA
	Phosdrin
	Trithion
	Parthoin
	Mathlparathion

(

(

(

)

(

(

(

(

(

(

-
-
-

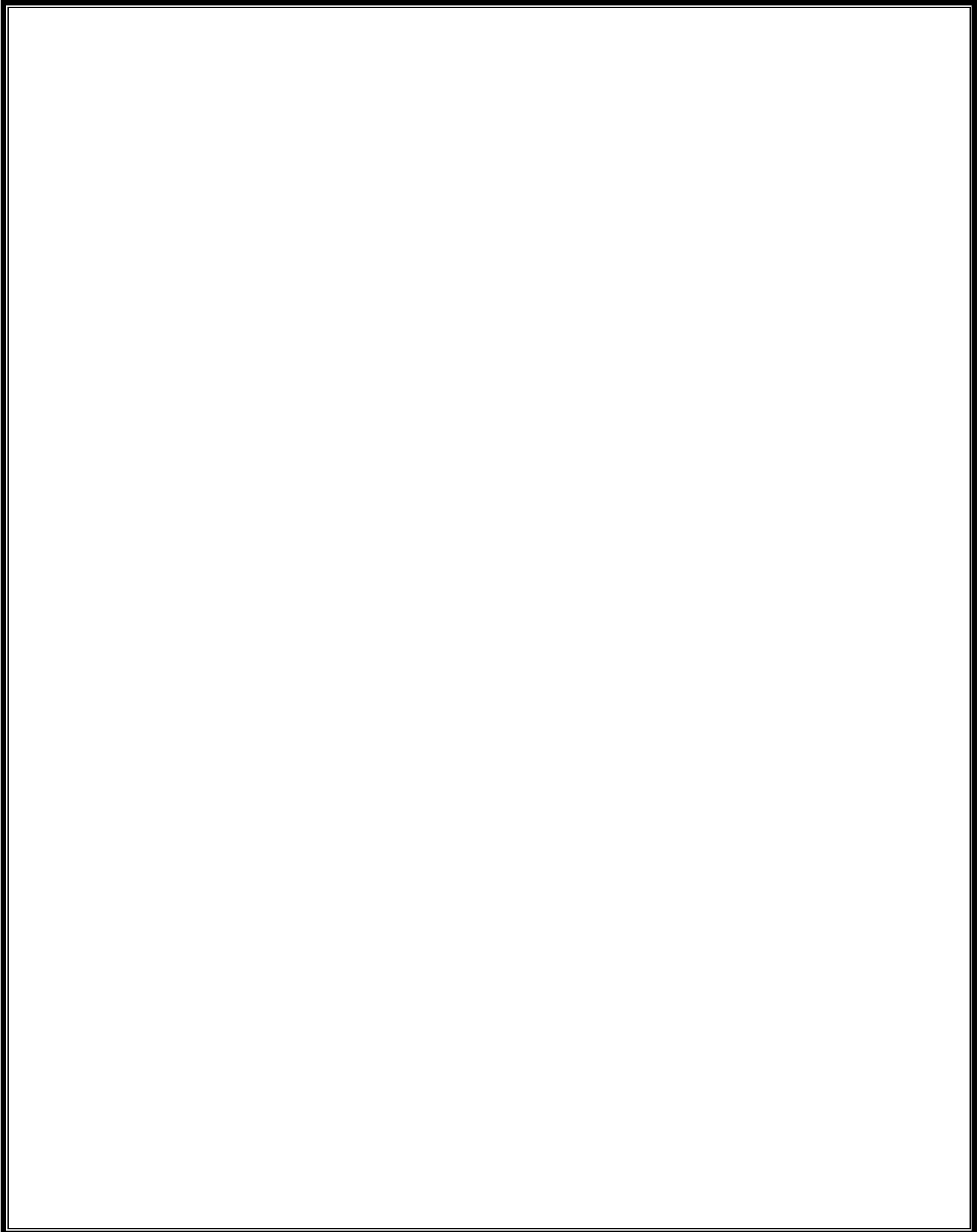

▪ :PETN

▪ :T.N.T

▪ R.D.X

D.M.S.O

T.N.T

D.M.S.O

D.M.S.O

D.M.S.O

()

:

(.....)

()

()

) ()

(

()
()

) () :
() :
()

()

.()

. ()

.

.

-
-
-
-

)

.(

()

.....

(
(
(
(
(
(
(
(
(
(
(
(

()
()

▪
▪

(A) ()

+

:

:()

()

:()

()

()

()

(
(
(
(

()

- -
 -
 -
 -
- () : .
- ()

-
- (
 - (
 - (

:

:

(

(

(

(

(

(

(

(

(

(

(

(

.(

.(

)

)

()

:

▪

▪

()
()

.

. / /

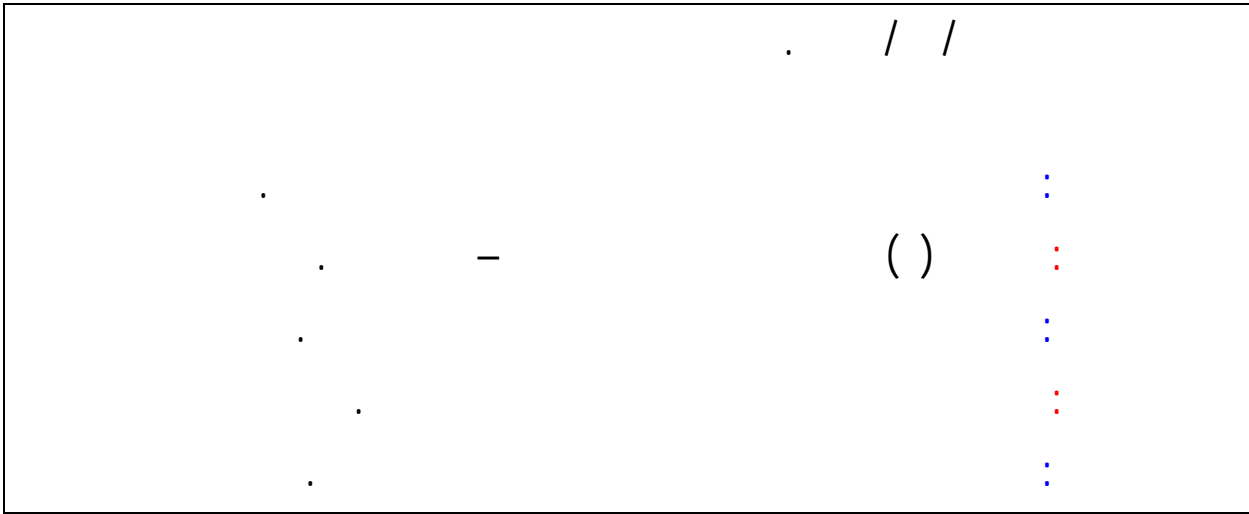

(

(

.()

(

()

()

()

:

(

(

(
(

)

(
()

_____ (

:

Phenol Phthalin (

(
(

Carbon Tetrachloride (

(

(

pint (copper sulphate)

(

(copper sulphate)

()

(

(MIT)

(ferrus sulphate)

(

(

.%

(

:

:

:

(

,

,

,

.crafito

()

.

:

(

▪

:

▪

(

-
-

:

.

(

-
-

:

() .

.

(

-
-

:

.

(

-
-

:

.

(

▪

:

▪

(

▪

.()

:

▪

(

+

▪

:

▪

(

▪

:

▪

(

· + · : · ■

(

· : · ■

(

· : · ■

(

· : · ■

(

-
-
-

(

-
-
-

()

-
-

(,)

-
-

Blank area for content with faint bleed-through text and four horizontal green lines.

-

()

+

()()

+

()()

()

()

() + () .

()

()

() .

()

. +

.

. + + (Paratoludin) + (Resoroinol)

+

.

.

.

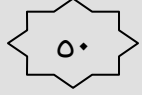

.

:

(

/

(

/

(

(

.()

(

(

(

(

▪

▪

(
(
(

▪
▪

+

▪
▪

()

+

▪

.

▪

.

()

▪

▪

.

.

+

+

+

▪

▪

.

. +

()

. + + . .

+ . :

()

. % :

▪

:

▪

▪

:

/

+ /

.

▪

)

(

.

▪

()

▪

.

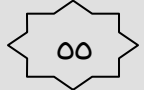

.

/ + /

.

.

+

.

.

.

:

.

.

.

.

'	'	
'	'	
'	'	

$$\cdot / \quad \times \quad \times =$$

:()

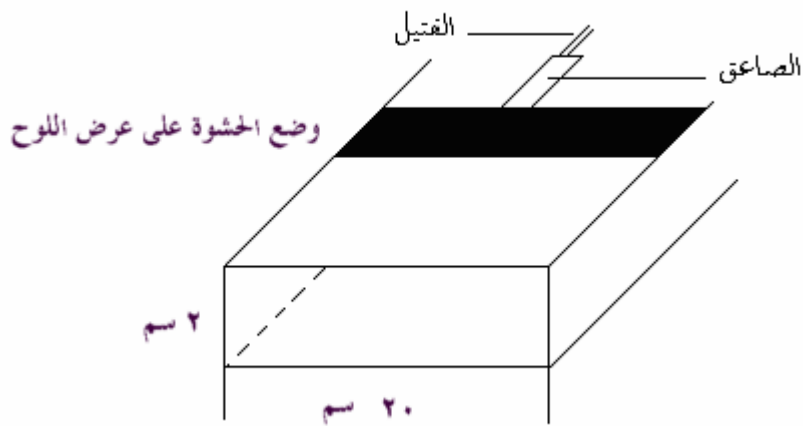

$() = () \times ()$ ()
 $() = \times$ ()
 $() = \times$ ()
 T.N.T , / ()

:()

. / × , = × () =
 .T.N.T , =

:()

/ (× , = × (,) =
 . T.N.T =
 : : =
 = =
 =

((/ (×)) × = :

:()

(H)

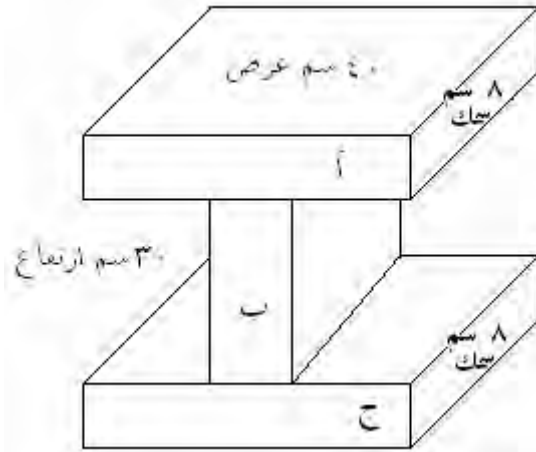

:

() () ()

:() :

= (

= (

= (

= × = (

((/ (×)) × = :

:

, =

, = × , (

() = × , ()
 () = / ()

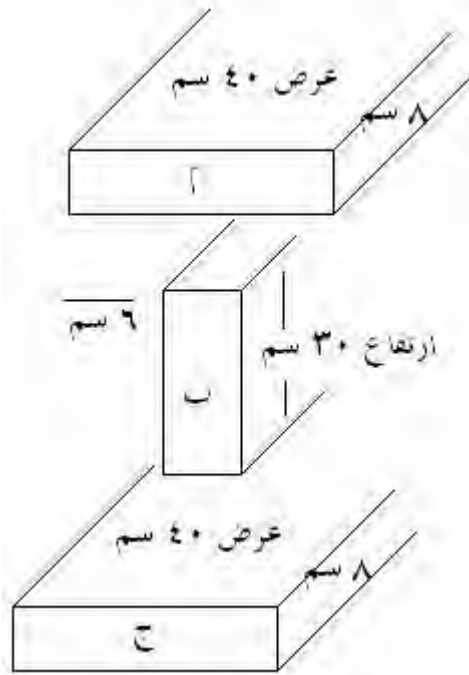

:() :

, = × , = × :

= × , :

= × :

() , = / ()

:() :

, = × , ()

, = () × , ()

= () × , ()

() = / ()

$$\frac{() + () + ()}{}$$

$$, = + , +$$

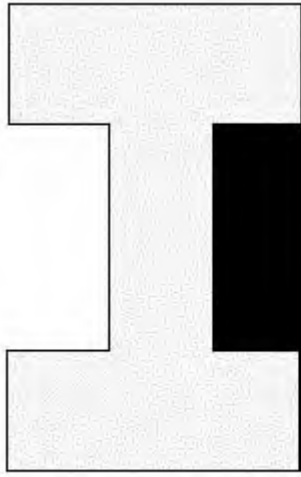

شكل (٢) مع حشوة مغمضة

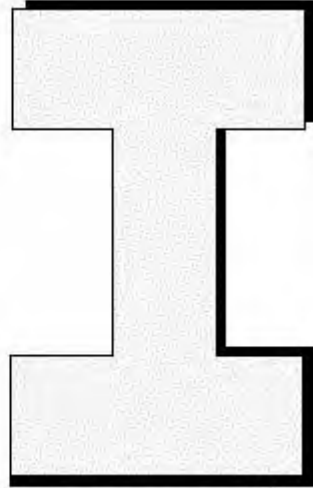

شكل (١) مع الحشوة

:

()

$$, = \times ,$$

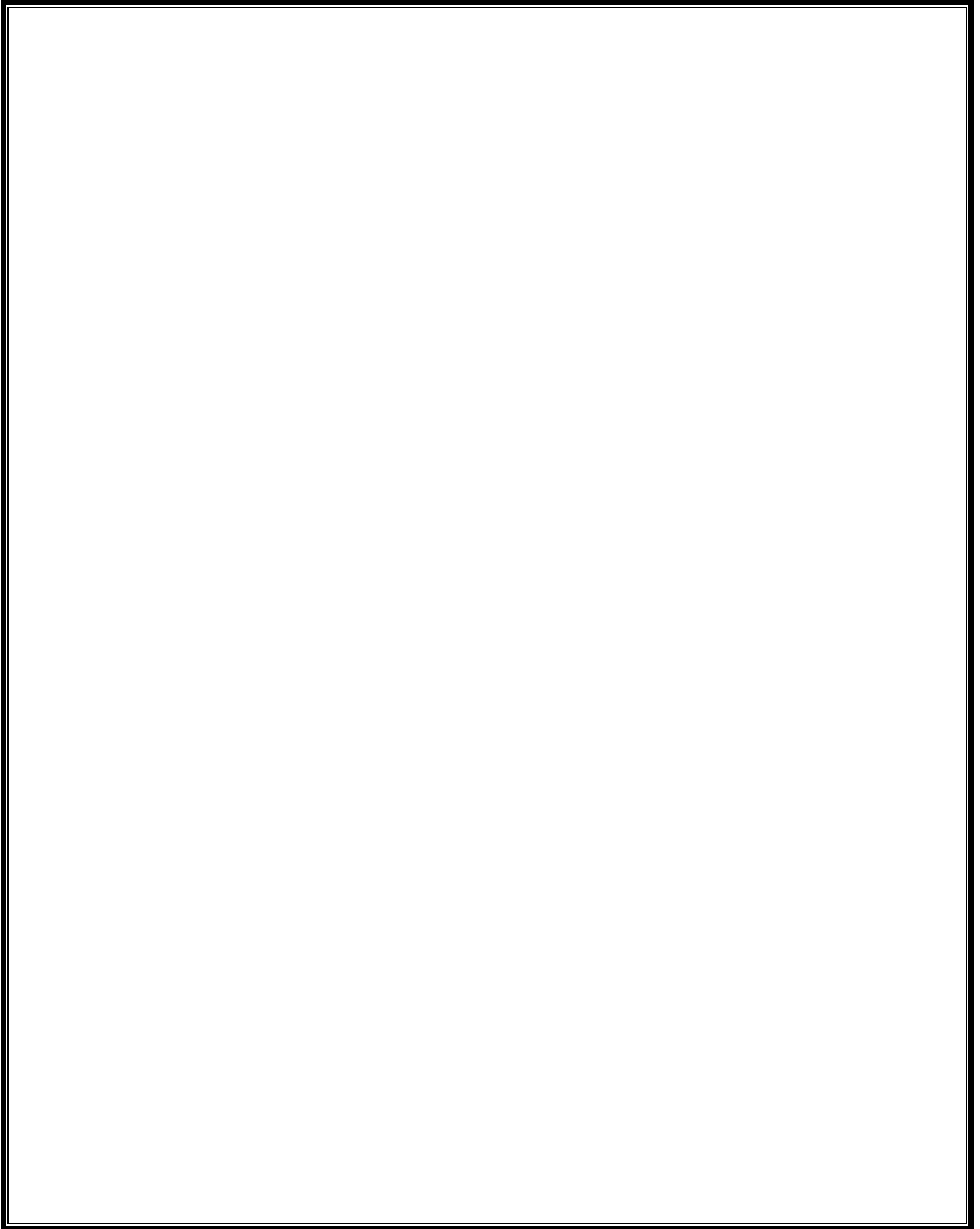

:()

$$/ (\times) = :$$

$$/ (\times \times \times ,)$$

$$, = / , =$$

:

=

=

=

=

$$/ (\times) = :$$

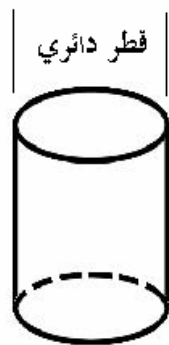
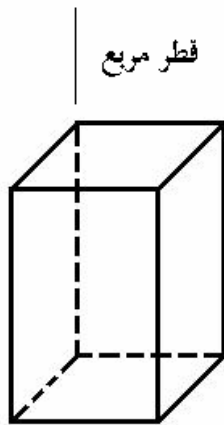

:()

$$/ (\times) = :$$

$$\begin{aligned}
 & \cdot () \quad (\\
 & \cdot = (\times \times) \quad (\\
 & \cdot = \times \quad (\\
 & \cdot \text{T.N.T} = / \quad (\\
 & \cdot \quad (
 \end{aligned}$$

:

—

—

:()

$$\begin{aligned}
 & \cdot (/) \times , : \quad , \\
 & \cdot \quad , = \times , \quad (\\
 & \cdot \text{T.N.T} , = / , \quad (
 \end{aligned}$$

:()

/ × ()

. = × ()
= / ()

:

▪

: (× ,)

,

.()

▪

(/)

.()

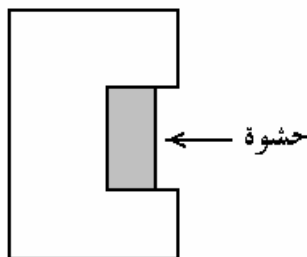
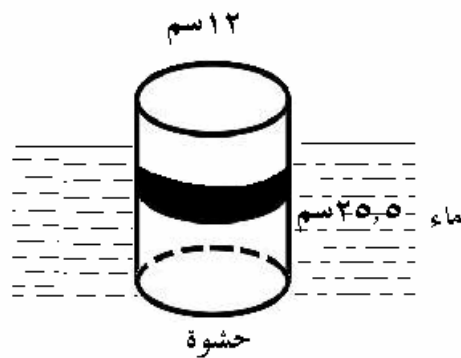
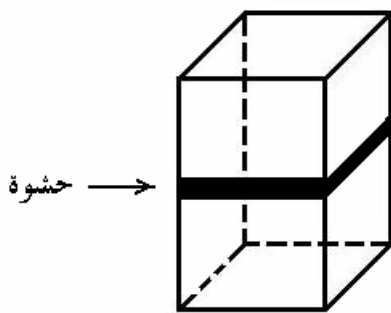

:()

▪

يوجد صفحة ناقصة

.T.N.T = × = ▪

., / = : × = : ▪

. × =

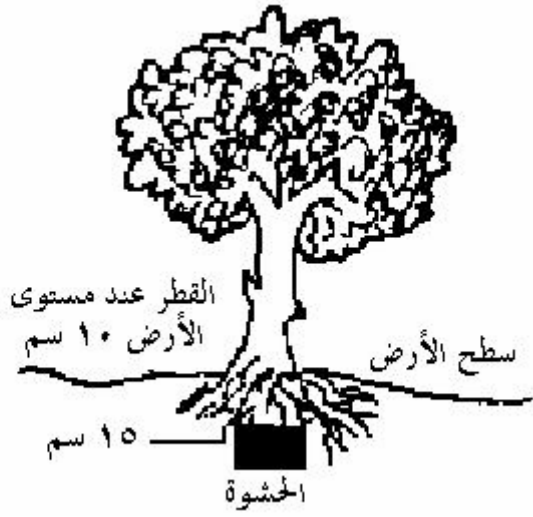

:

_____ :

. × × () = _____

_____ :

.T.N.T = () × () , × = :

_____ :

. × × () = _____

_____ :

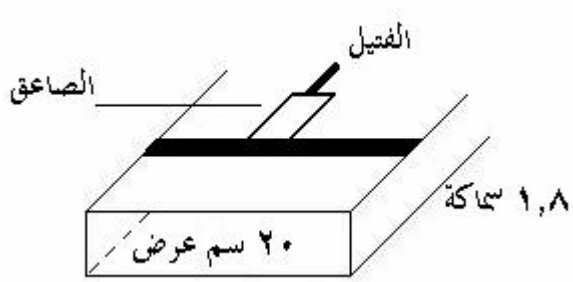

_____ :

.T.N.T , = () × (() ,) × = :

:

. × × =

:

:

T.N.T = × , × ■

■



. × × =

. ,

. × , × , × = ■

T.N.T , = ■

:

.

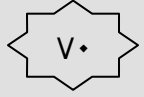

:

-
-

=

× ()

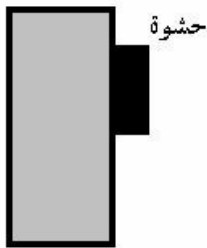

T.N.T , = , × , × = () (,) × =

:

$$\wedge \times =$$

=

_____ :

. × ()

: _____

. ,

: _____

() ^ , × = :

T.N.T , = , × , × , ×

:

$$^ \times =$$

() _____

^ =

. ^ =

.

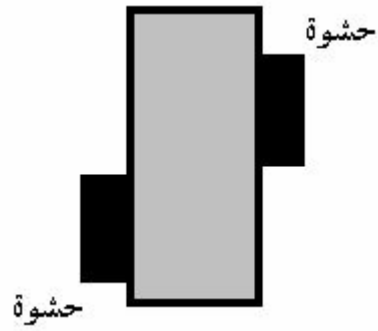

:

:

:

T.N.T

T.N.T

:

/ (

⋮

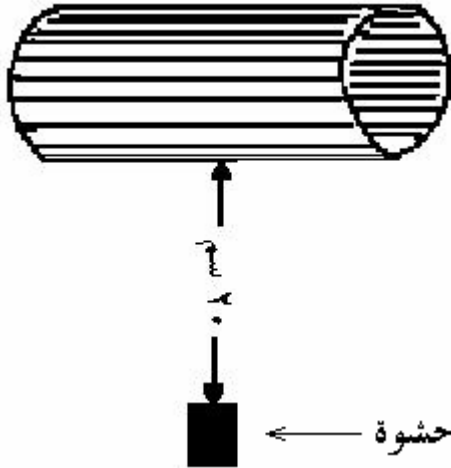

⋮

\cdot , (/) = (

\cdot , (/) (

\cdot / (^ , x , x , x () = (

\cdot T.N.T = (

$=$ $=$ $=$ $:$

\cdot = $=$

$/ (^ x x x = :$

(

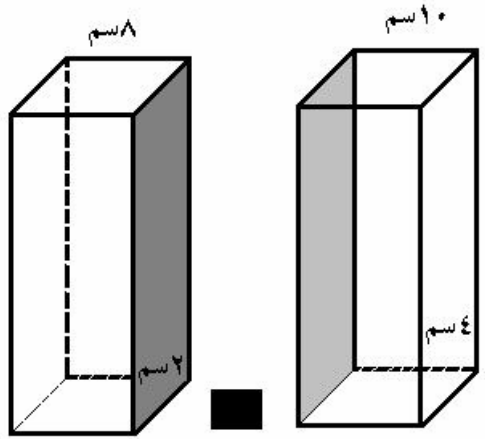

:

(

- , = = ■
- , = = ■
- , = = ■

/() × × × = :









T.N.T , = , / (^ ,) × , × , × =

:

-	,
,	
,	
,	
,	

.

= :

=					
=	,				
/ =	,	,			
÷					
=	,	,			

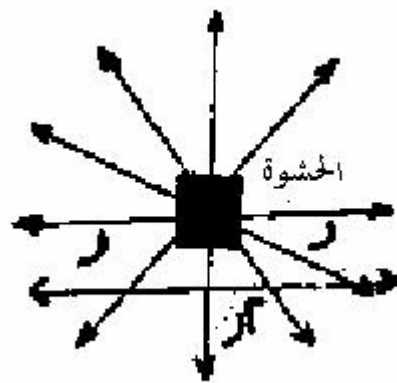

_____ :

.()

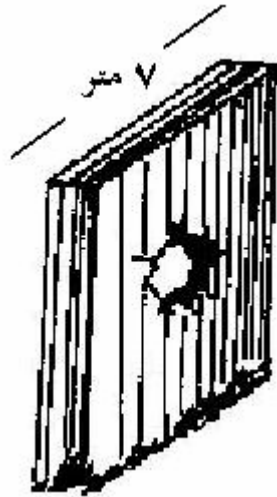

:

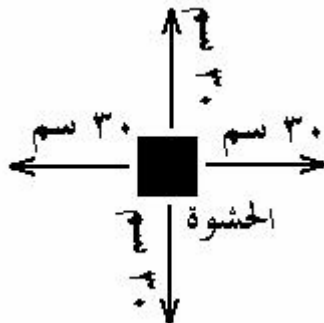

. / [] = = .

- = (,) / = = :
- = , × = × :
- . ,
- .
- :
- / [× () × ×] =
- . / [× × ×] = :

- =
- =

,	,	,	,	,	,
,	,	,	,	,	,
,	,		,	,	,
,	,	,	,	,	,
,	,	,	,	,	,
,	,	,	,	، - ،	، -
,	,	,	,	، - ،	، - ،
,	,	,	,	، - ،	، - ،
,	,	,	,	، - ،	- ،

:

) × × () :

(

$$\times \times =$$

:

▪

▪

▪

×

×

×

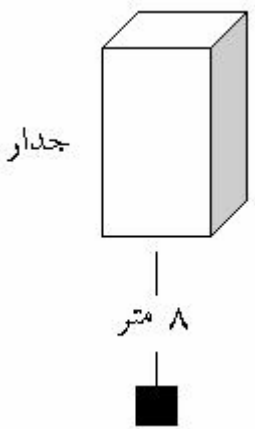

.T.N.T

:

=

.T.N.T

×

=

▪

▪



:

× () × () , =

:

× =

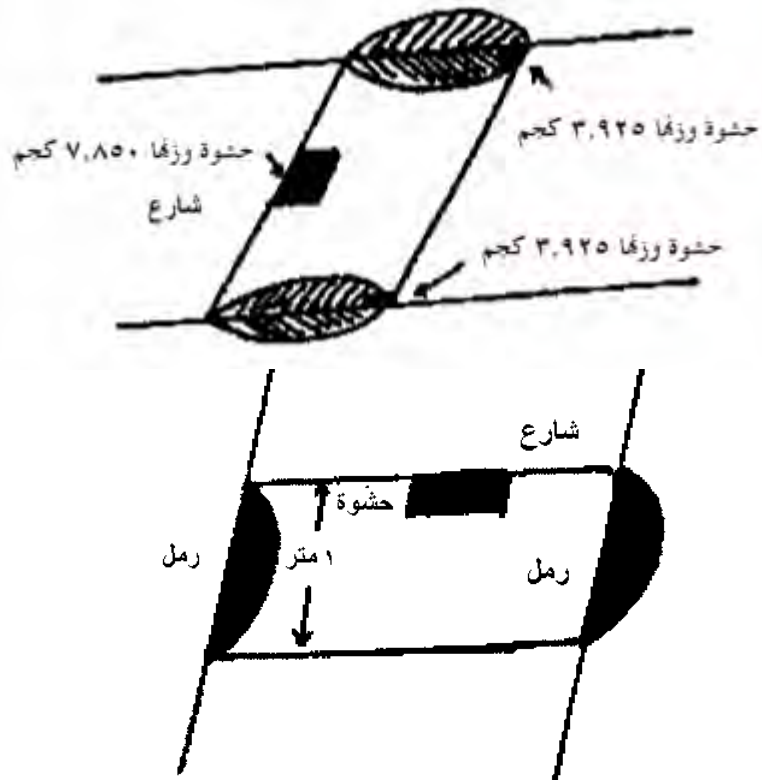

() ... :

:

() × () × = ▪

· + = : ▪

() = = ▪

()	
,	
,	
,	
,	
,	
,	
,	
,	
,	
,	
,	
,	
,	

T.N.T

:

:

:C3

T.N.T

.T.N.T

, =

C3

(

.C3

, ÷

(

:C4

.T.N.T , = C4 (

.C4 = , ÷ (

:

. ÷ = (

.

(

: _____

: _____

. = ÷

:

:

.

.

.

.

.

.

.

()

-
-
-

()

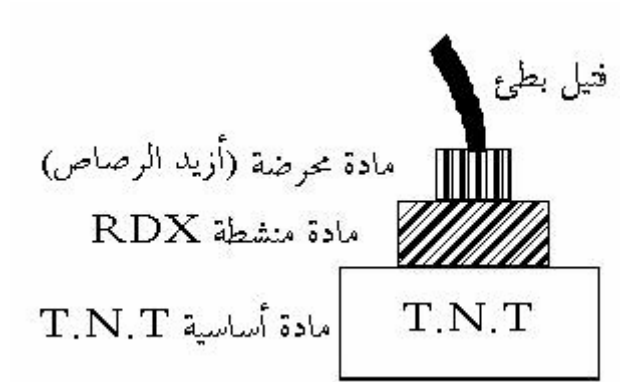

())

.(%

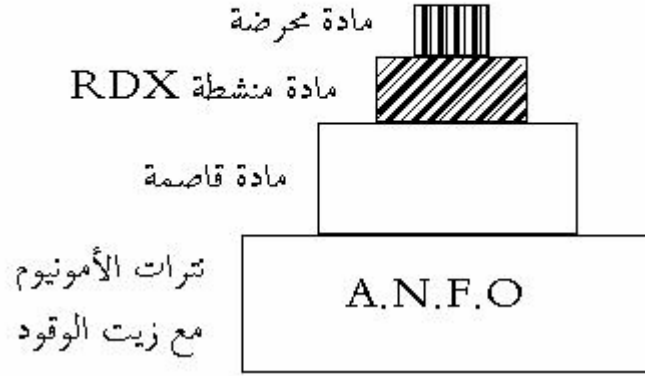

:

:

(

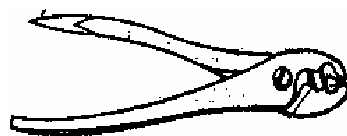

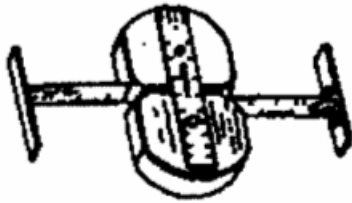
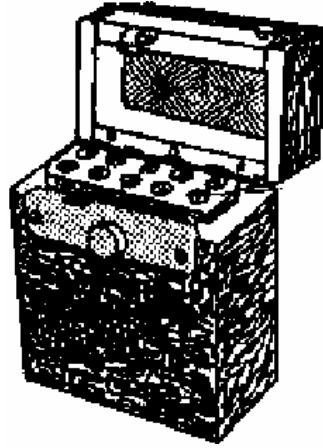
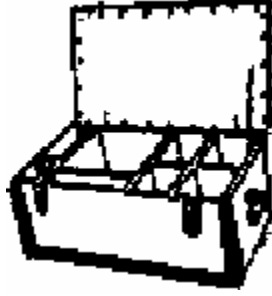

شريط حاسب



:

()

:

()

()

()

()

()

()

:

()

()

()

()

()

()

:



()



()

T.N.T

:

:

()

▪

▪

R.D.X

()

R.D.X

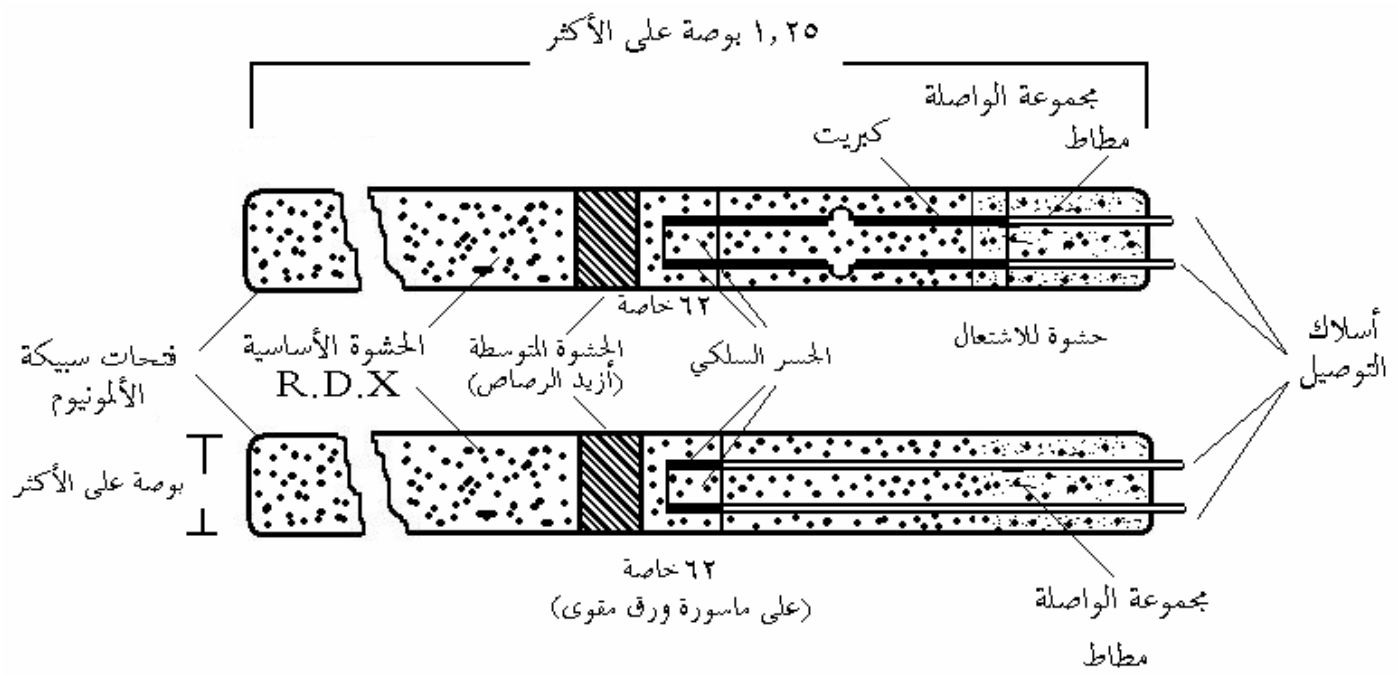

()

_____ :

()

: (

)
() .(

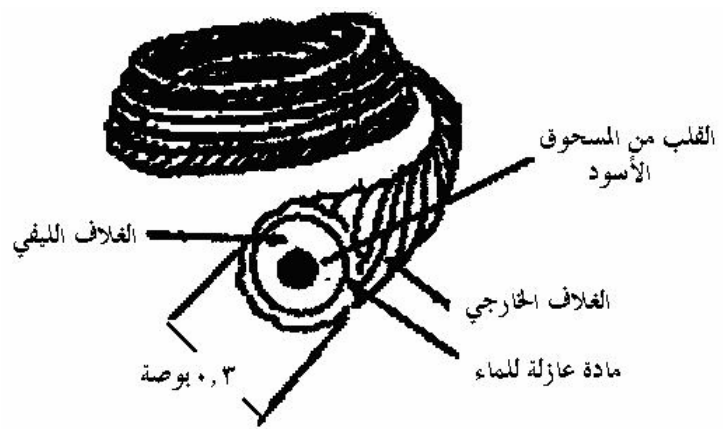

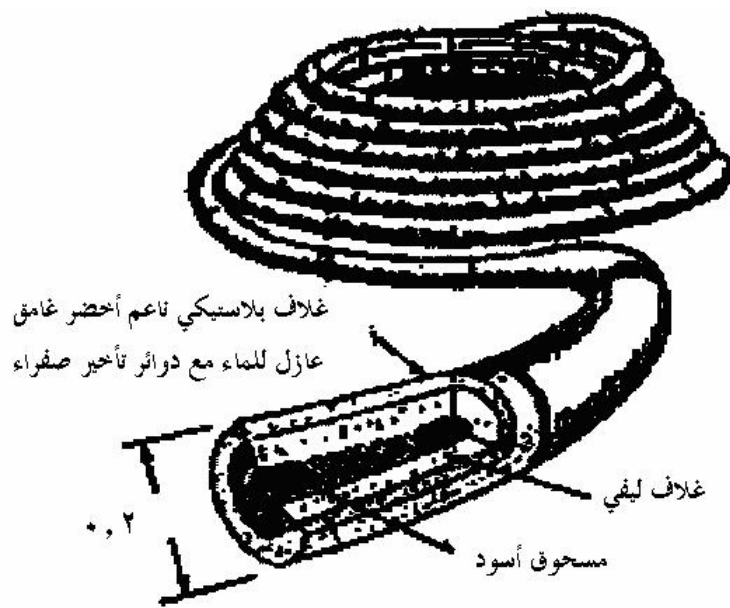

(: /)
.
: : ()
) (/)
.

:
()
.
() : ()
())
.
()

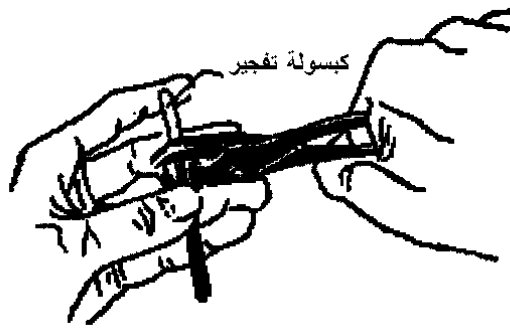
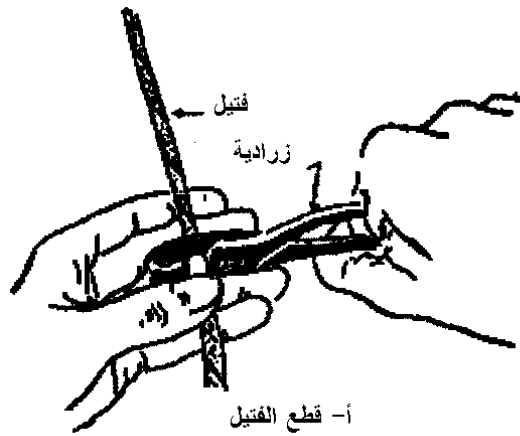

(

)

.(

(

(

(

(/ - /)

(

.

.

:

(

)

.(

(

()

(

.

:

: ()

(

.

(

(

(

:

()

-()

-

()

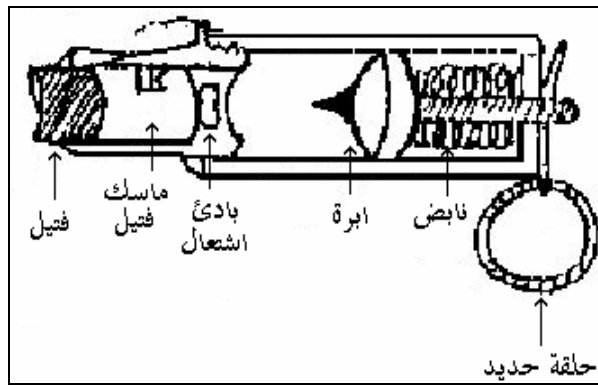
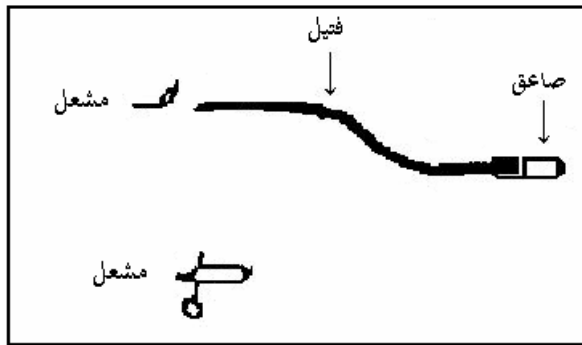
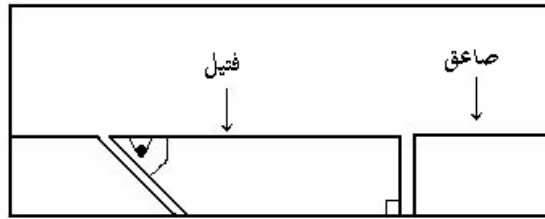

:

: _____

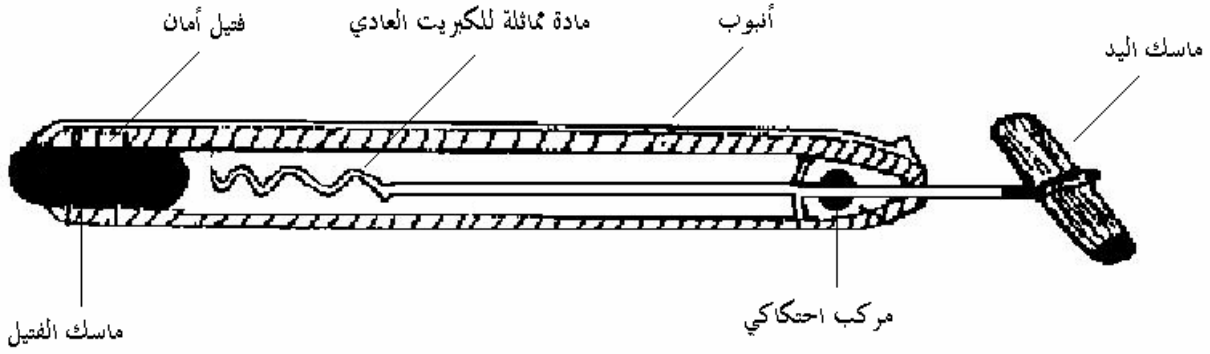

() :

(PETN) :

/ /

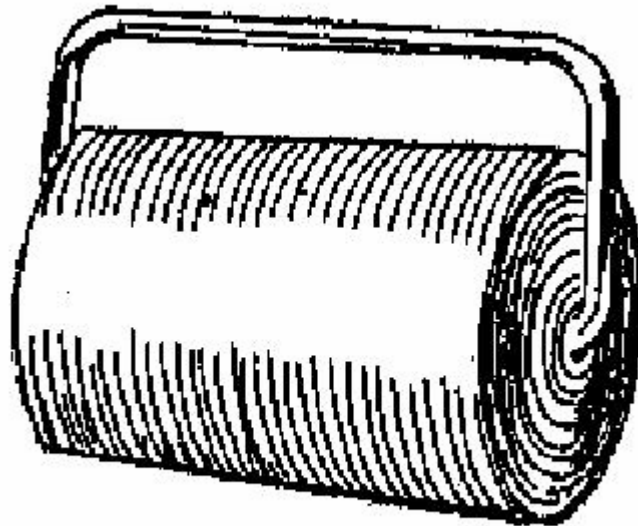
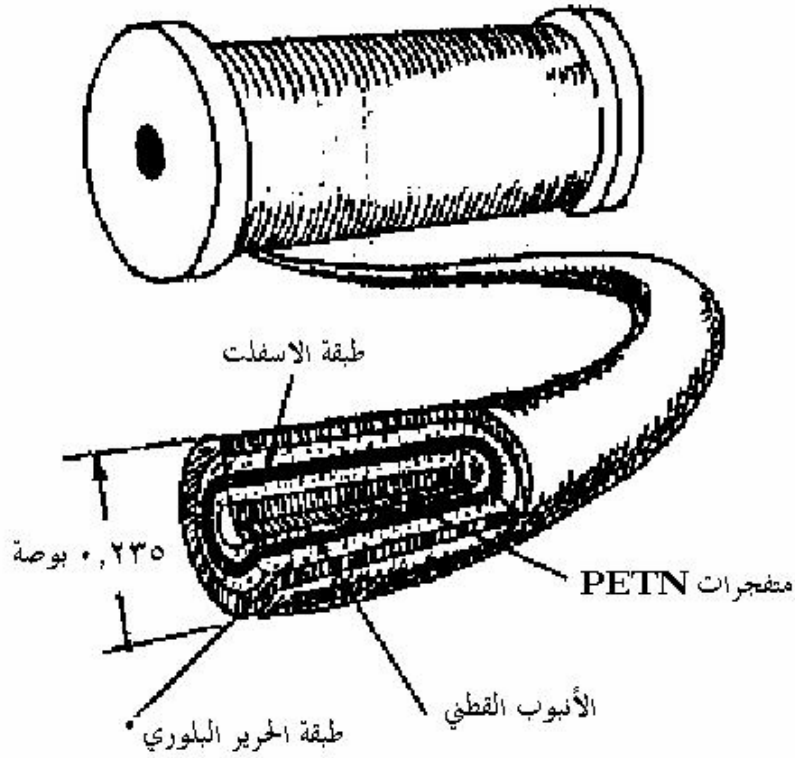

فتيل التفجير المتوي المغلف بغشاء مطاطي خفيف

:

. / (-)

(

(

.() ()

(

(

(

(

(

(

(

. (-)

(

(

(

()

:

:

(

(

(

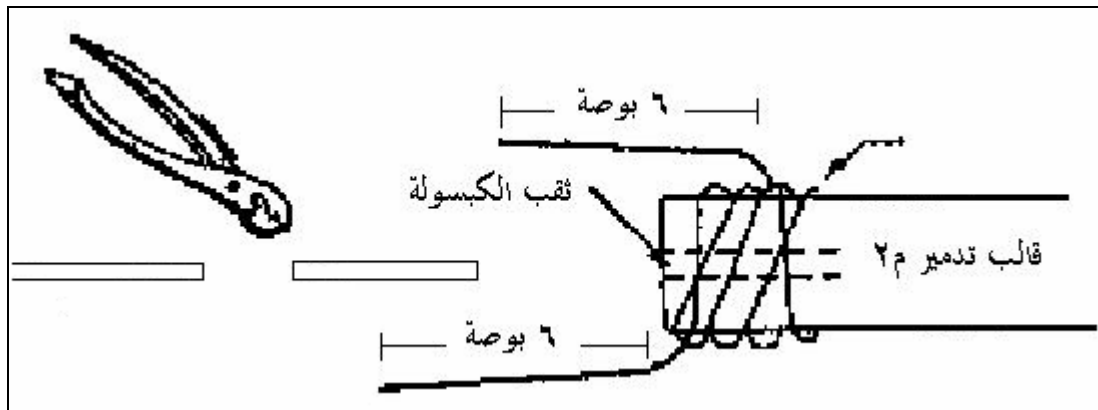

:

(

(

(

(

(

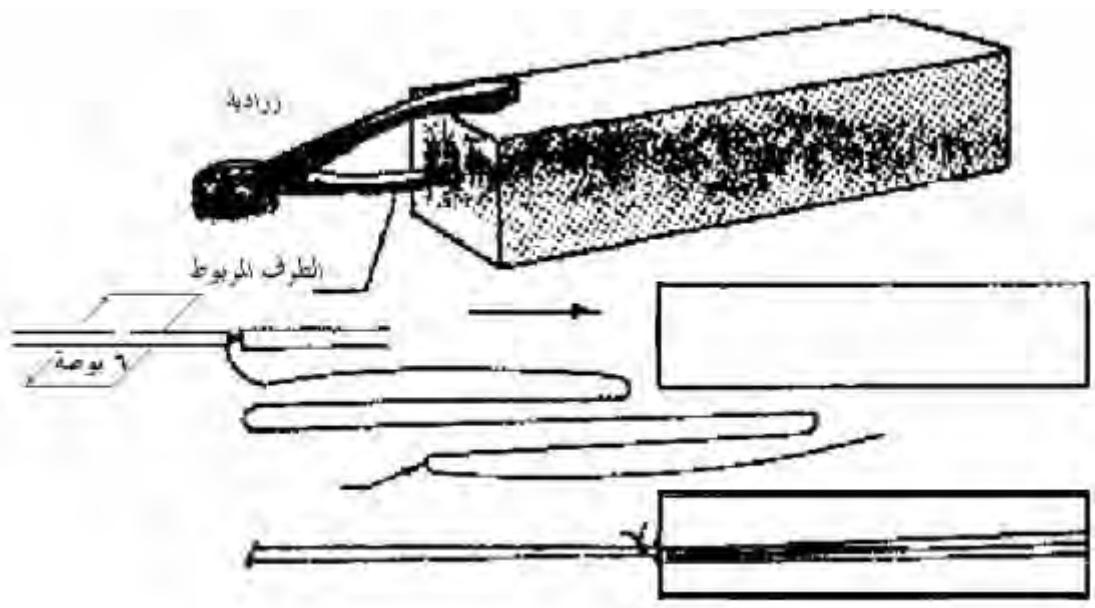

:

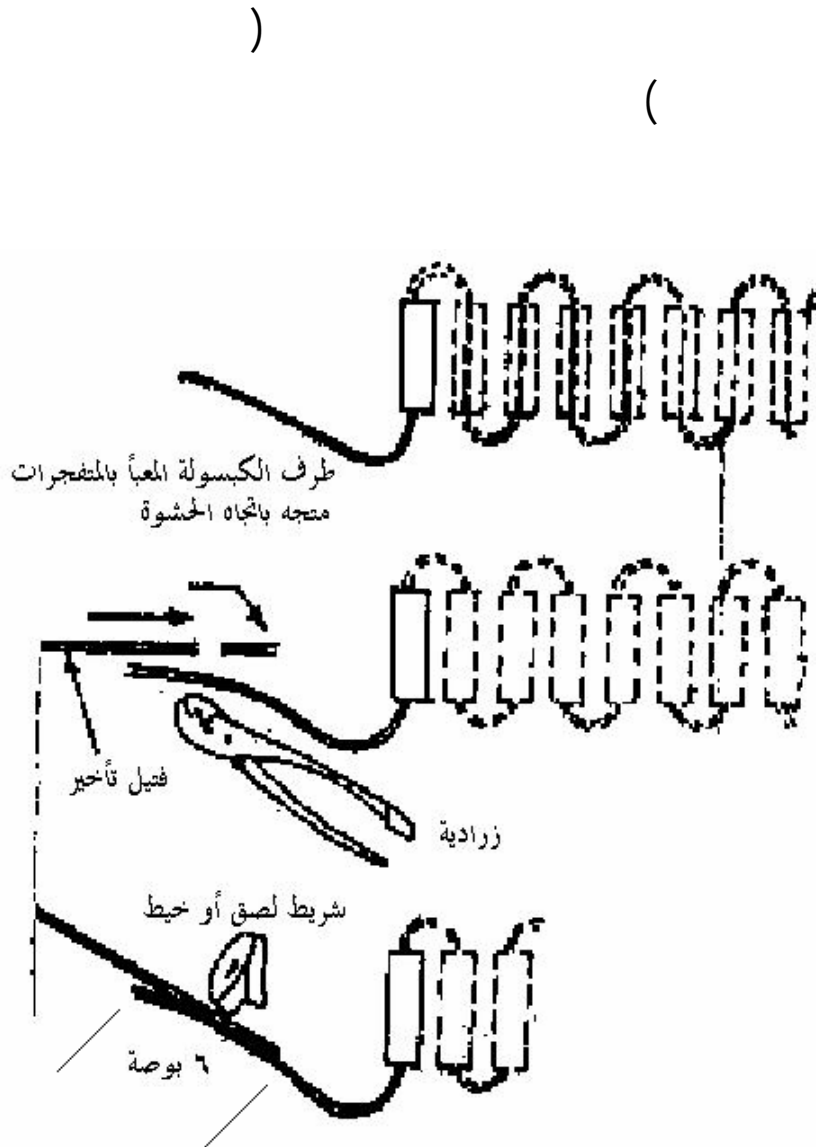

:

(/)

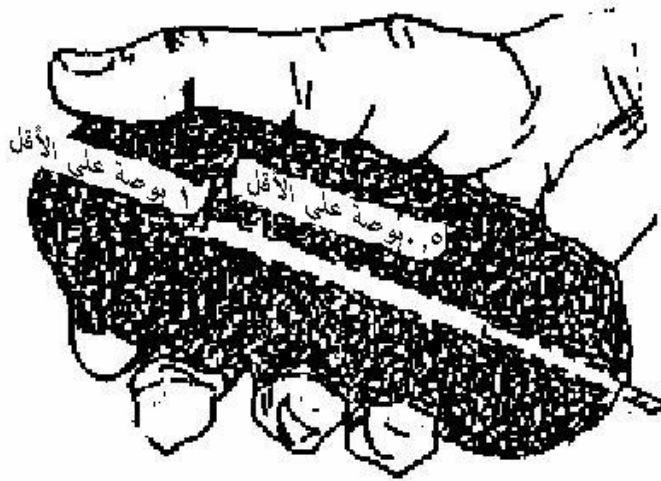

:

(

(

(

(
(
(
(
(
(

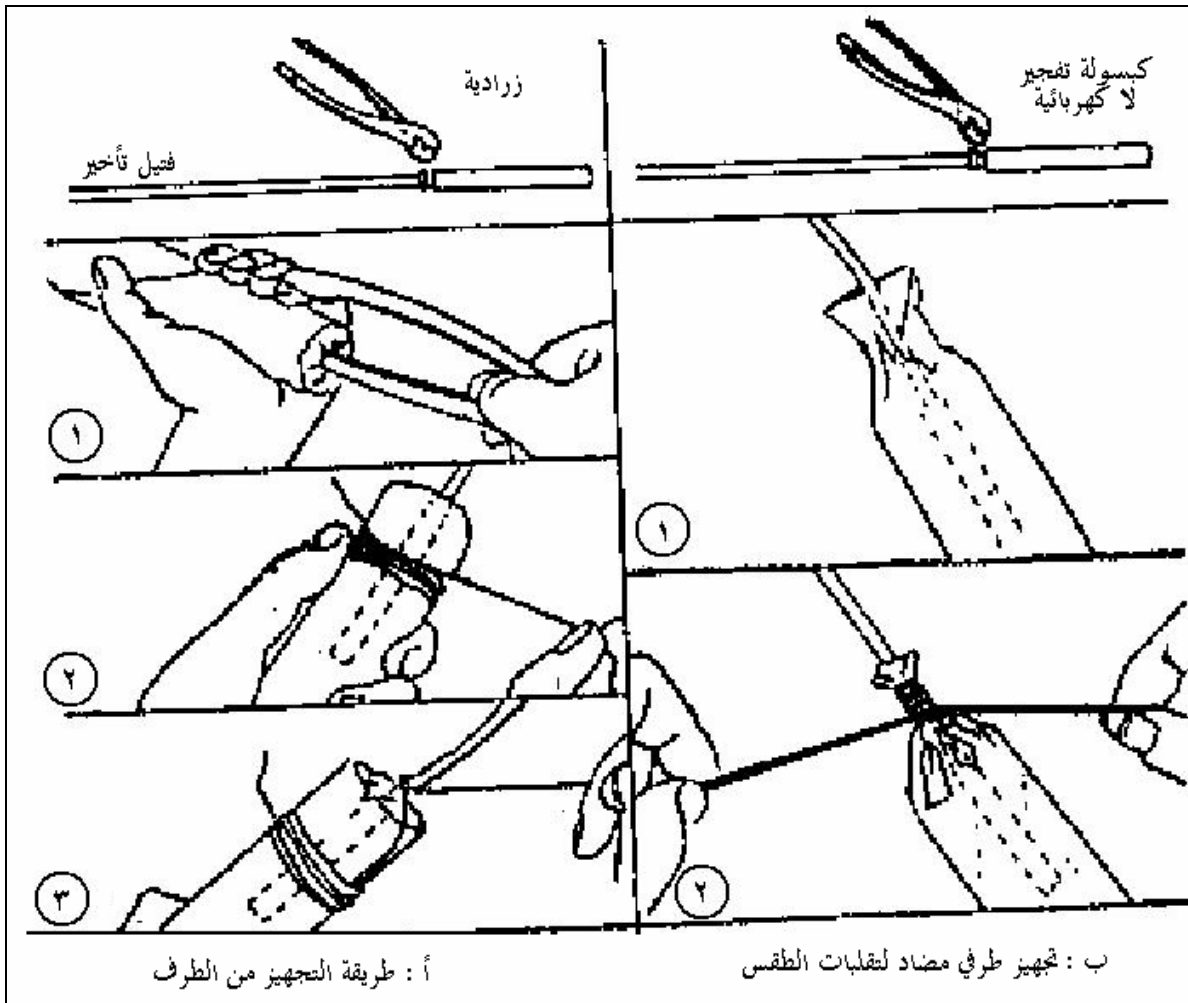

() :

(,) ((

- (((

_____ :

: ((: (

٢

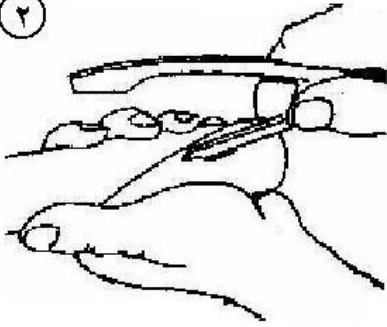

١

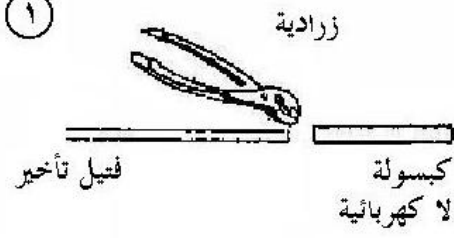

٤

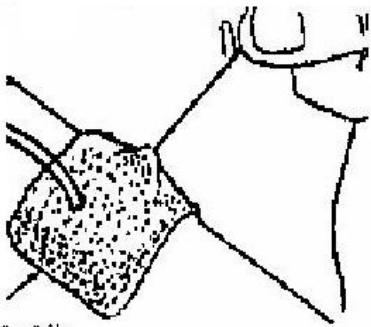

٣

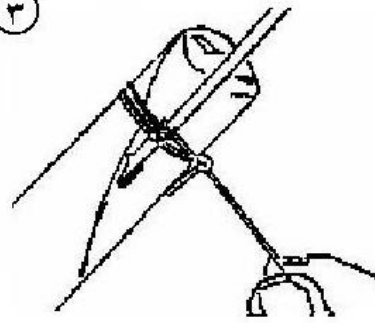
ملفة مقاومة
لتقلبات الجو

٥

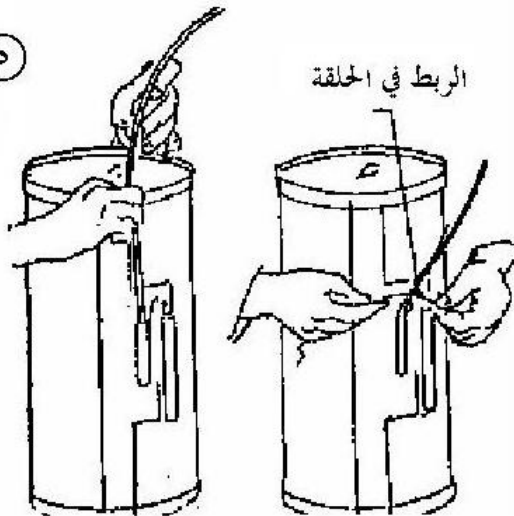

:
:
:
()
.
()
:
(
(
.
.
(
()
()

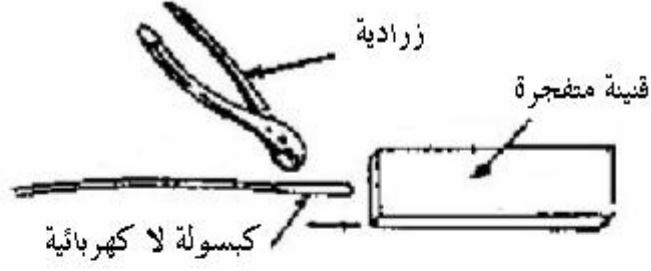

١- اقطع غرقة في الشريحة وأدخل الكبسولة وثبتها بحيط

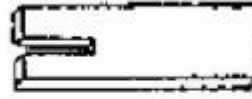

٢- ثبتها في الأعلى بواسطة قطعة شريحة من المتفجرات أو



٣- ألحم طرف الشريحة بعد وضع الكبسولة تحتها

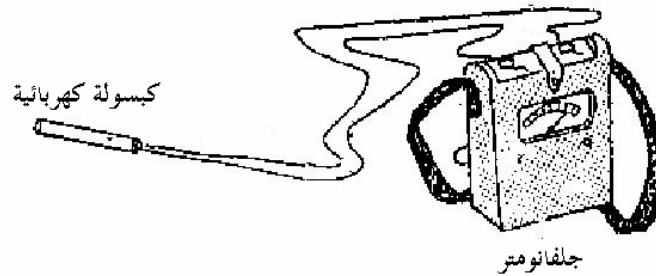
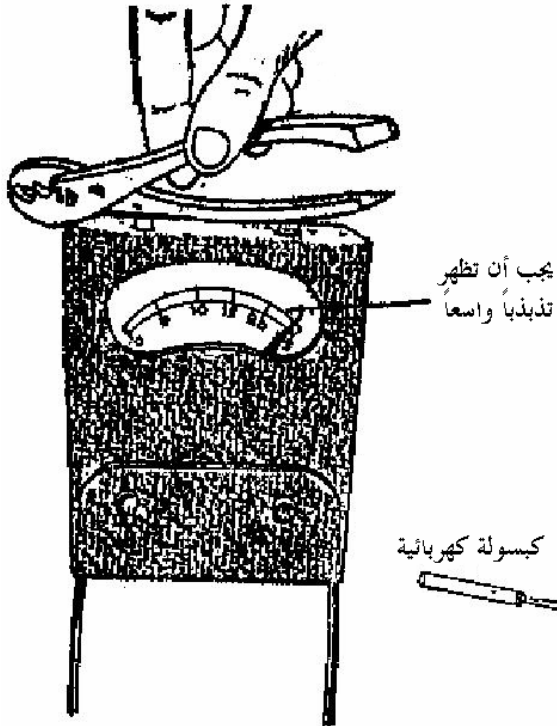
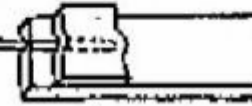

:

()

:

(

(

()

.

:

.

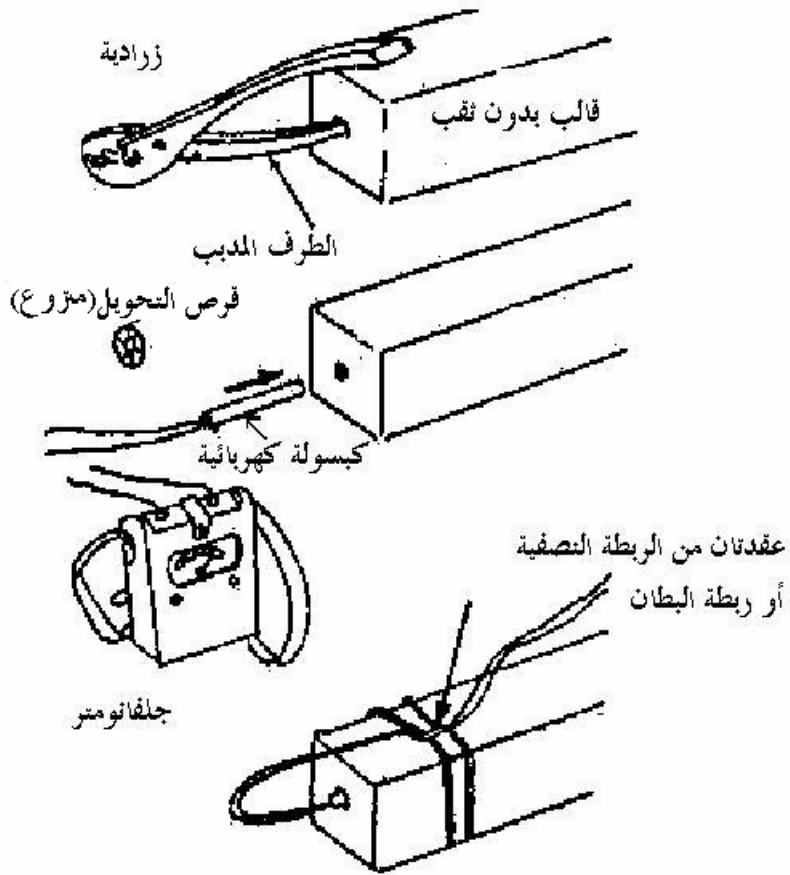

:

(

(

(/)

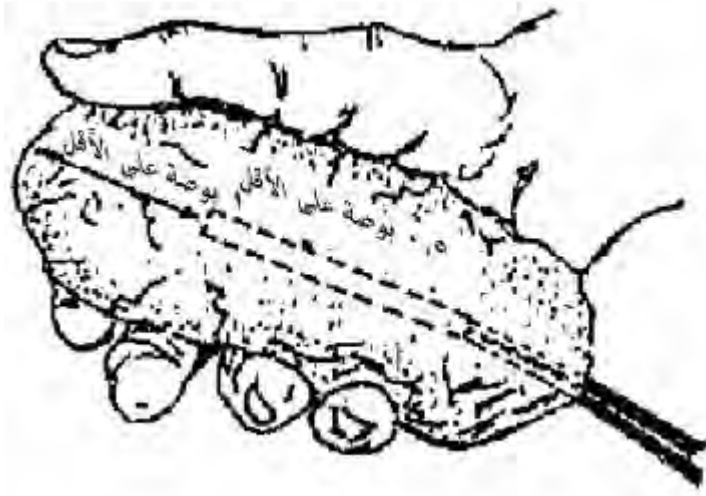

:

() .

(
(
(
(

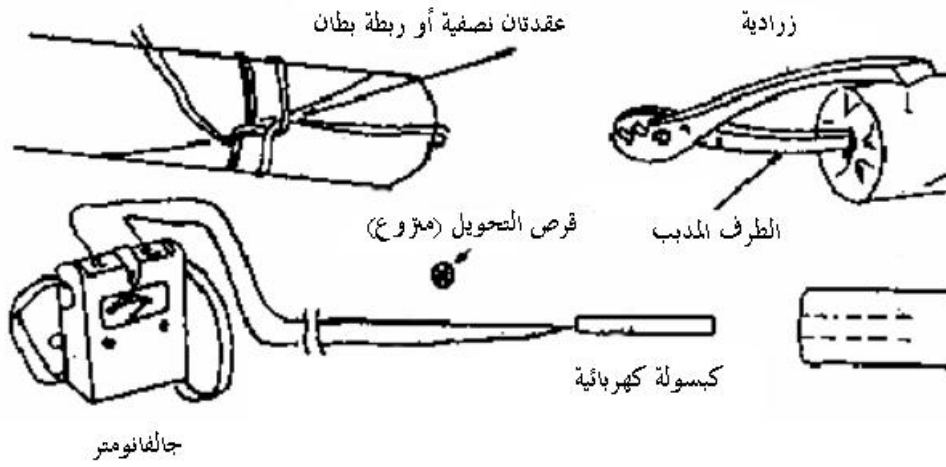

:

()

:

{ }

(

(

(

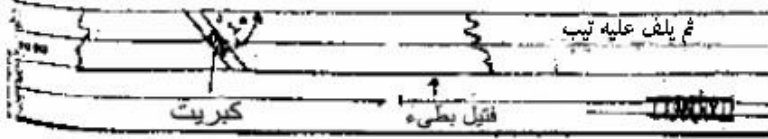

(

:

(

(

{ }

:

(

(

(

(

_____ :

_____ :

() _____ :

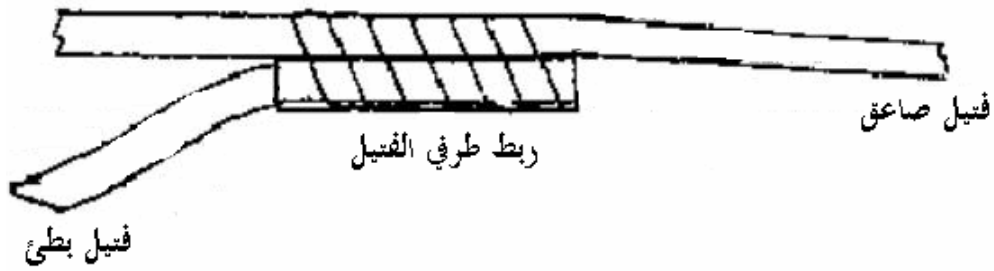

:

(

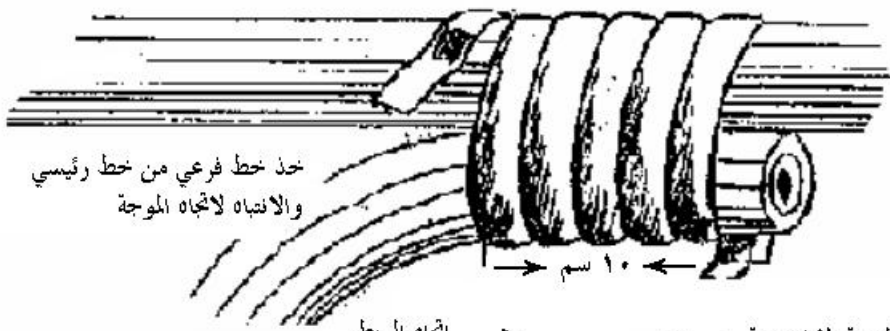
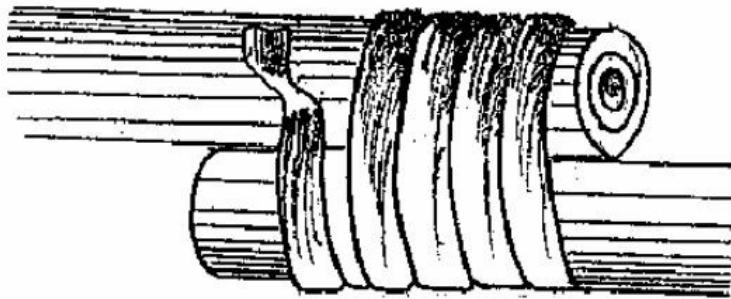

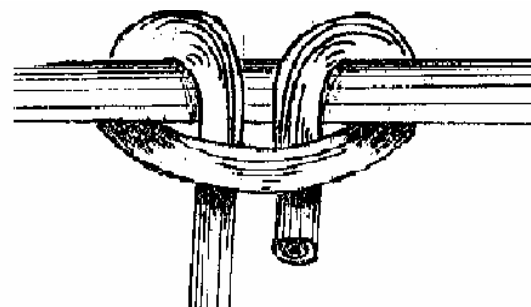
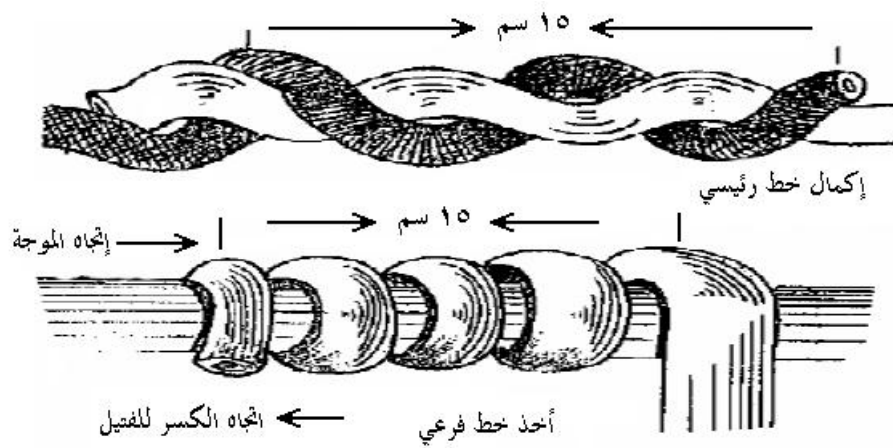

Y (

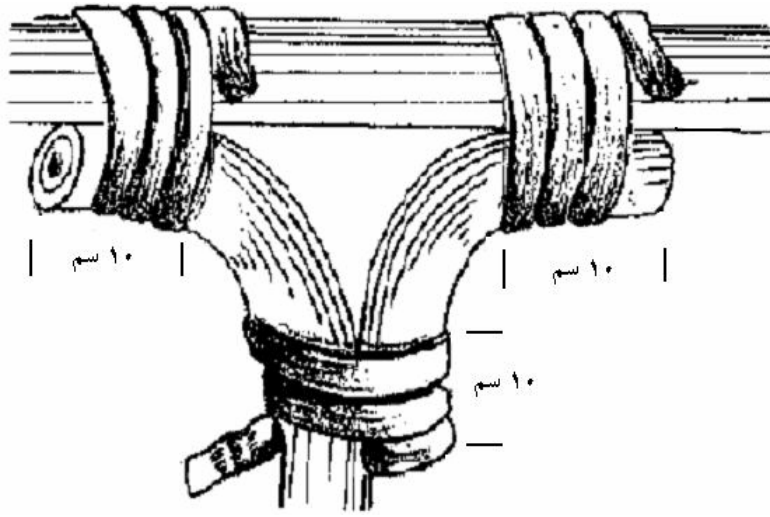

P (

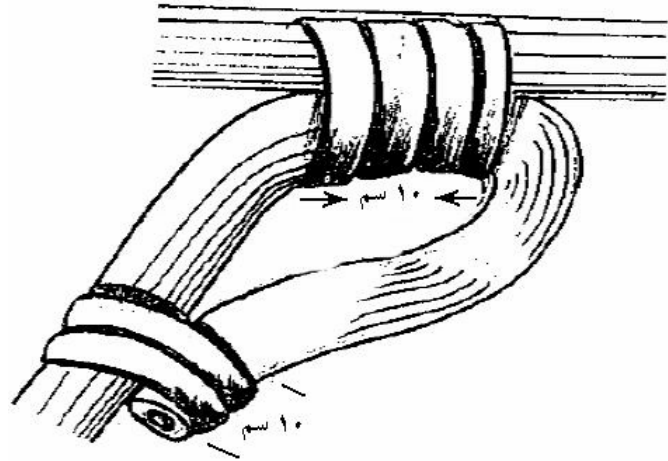

S (

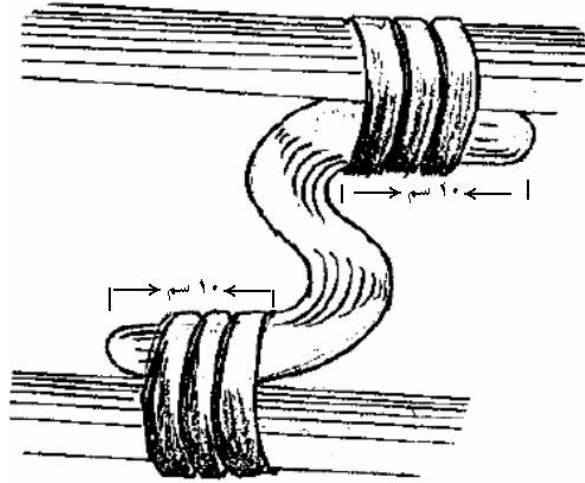

U (

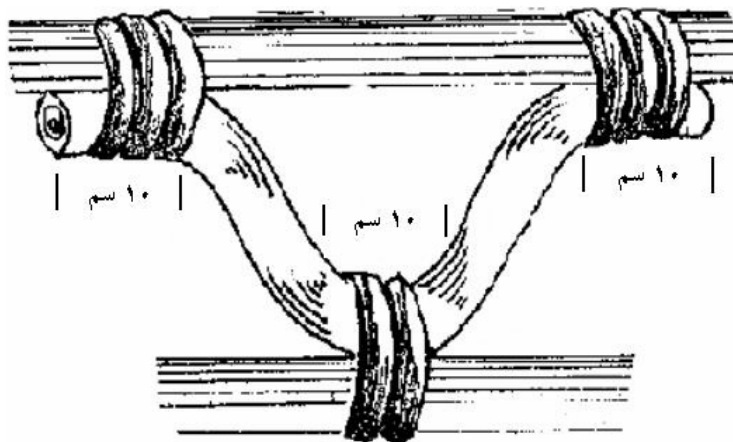

▪

▪

▪

(

(

(

(

(

) - - - - - (

+ (

(

٢- الطريقة البديلة رقم (١)

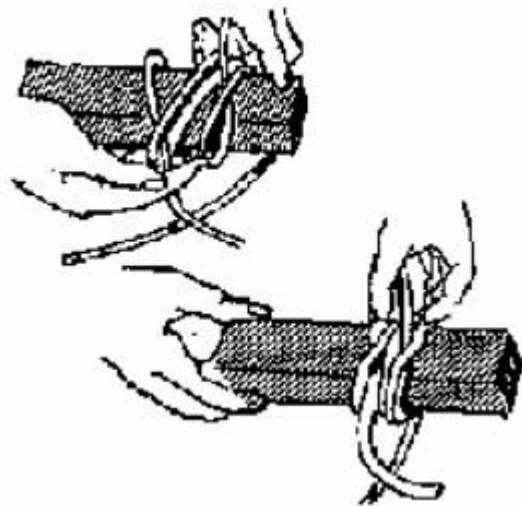

١- الطريقة العامة

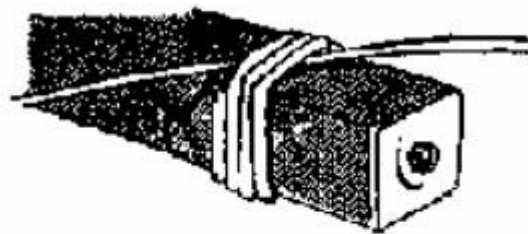

(

(

(

(

(

:

٣- الطريقة البديلة رقم (٢)

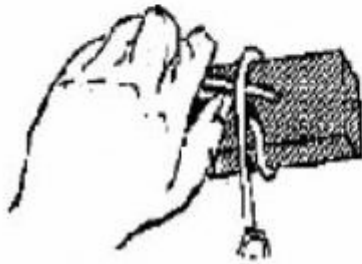
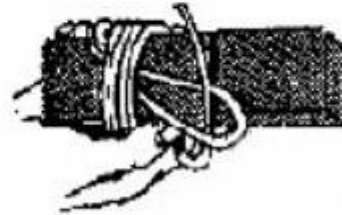
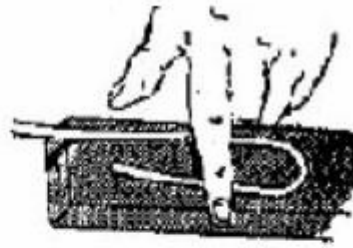

()

C4 C3

:

(

. /

(/)

(

:



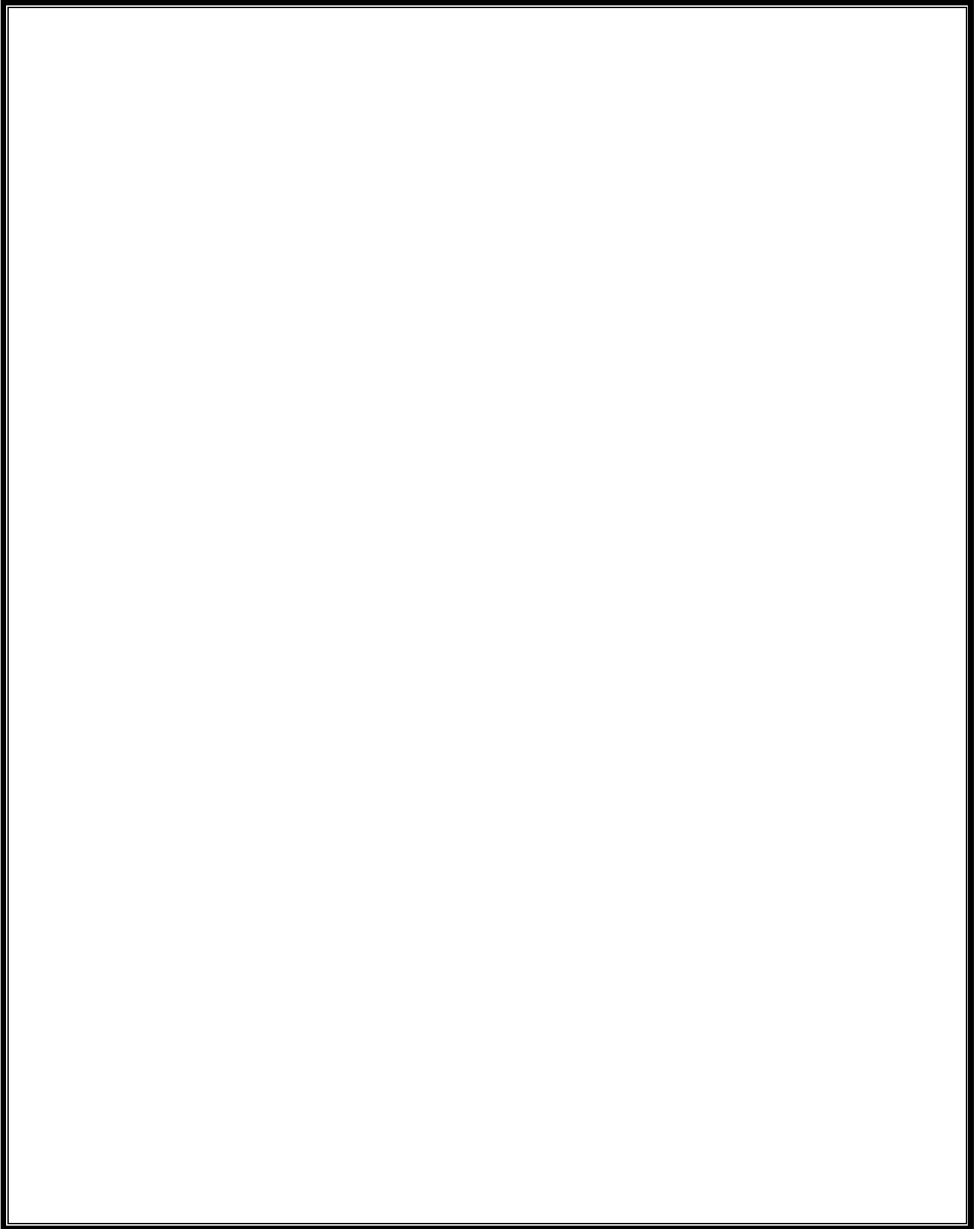

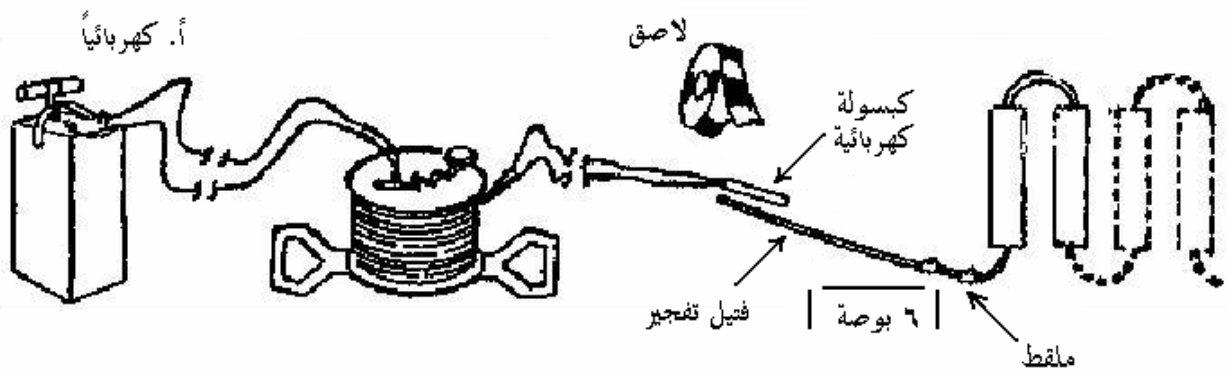
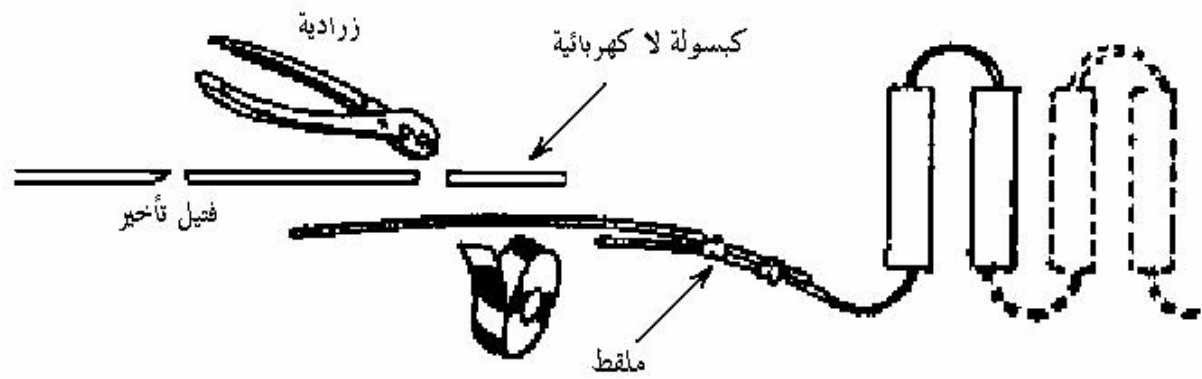

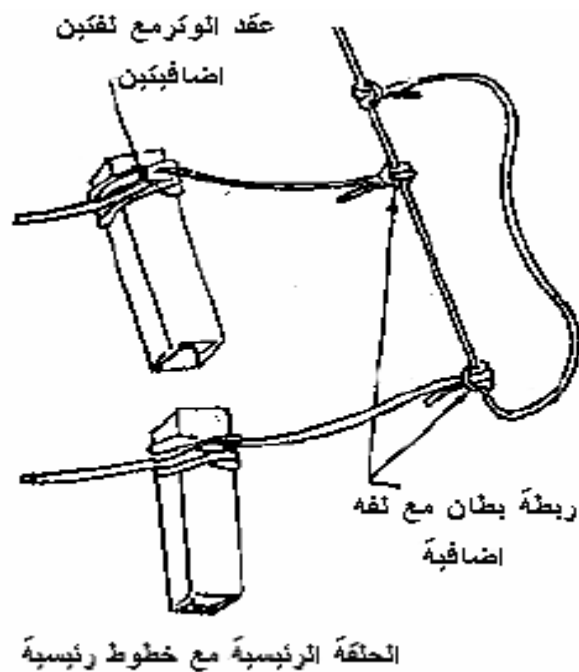

(

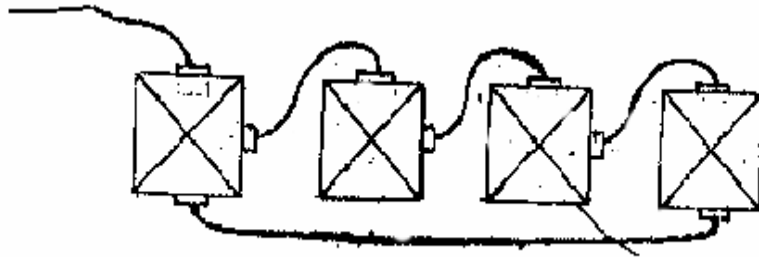

(

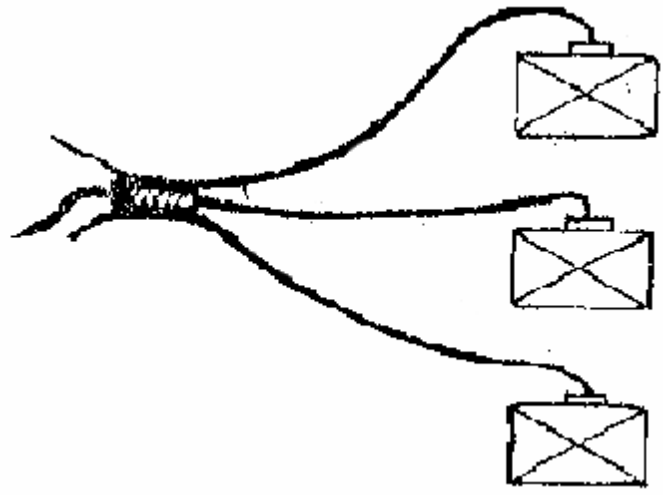

(

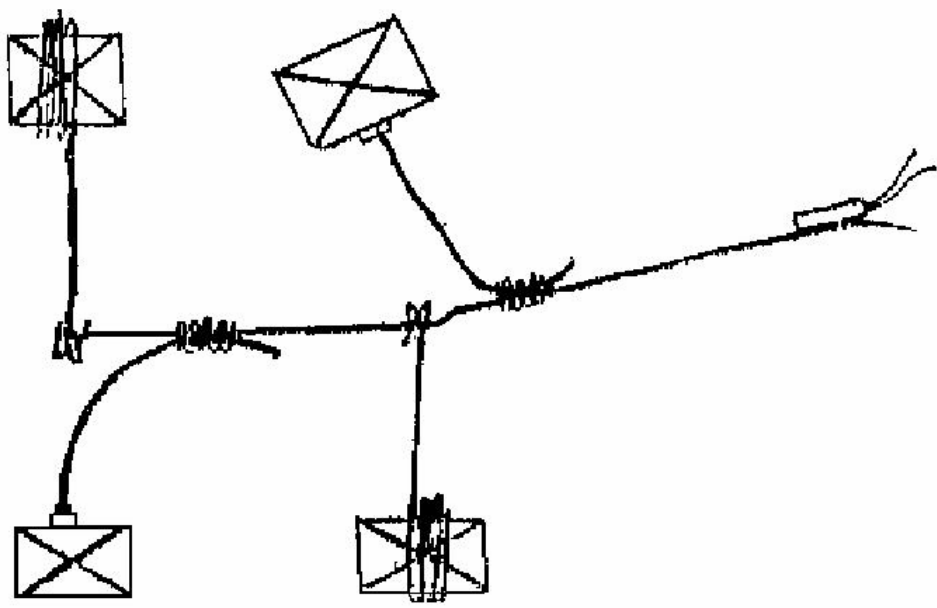

(

(

(

(

(

(

(

(

(

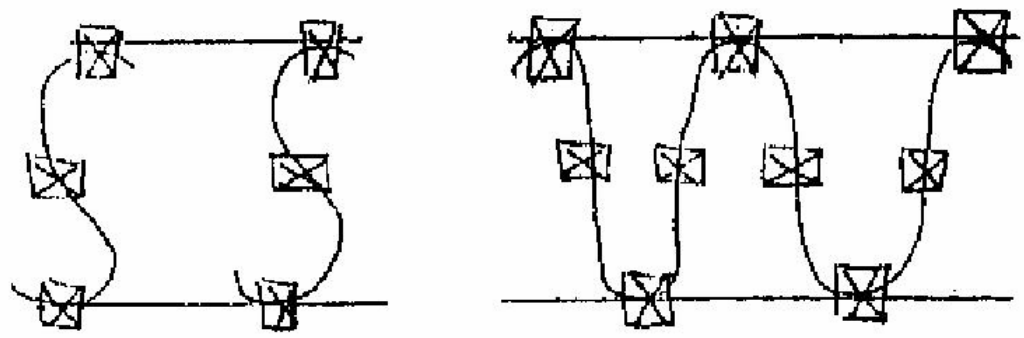

:

(,)

(

(

(

(

(

(

() .(

:

() :

(:

(,)

· ' (:

· ' :

(:

() () .(

_____ :

:

_____ :

(DC)

:

:() (

() ()

:

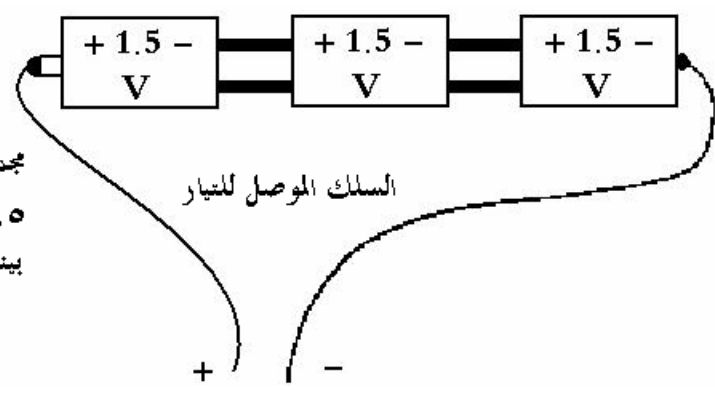

مجموع الفولت =
 ٤,٥ = ١,٥ + ١,٥ + ١,٥ فولت
 بينما التيار يبقى ثابت

, = , + , + , =

:() (

مجموع الأمبير =
 $3 = 1 + 1 + 1$ أمبير
 بينما الفولت يبقى ثابتاً
 ويساوي ١,٥ فولت

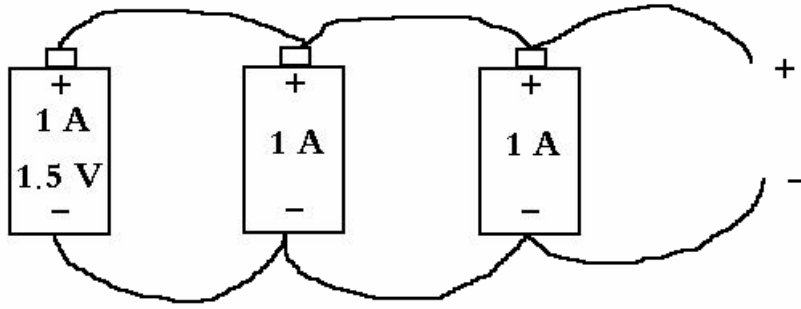

$I = I_1 + I_2 + I_3 = 1 + 1 + 1 = 3 \text{ A}$

:() (

$V = V_1 = V_2 = V_3 = 1.5 \text{ V}$

$R = \frac{1}{\frac{1}{R_1} + \frac{1}{R_2} + \frac{1}{R_3}}$

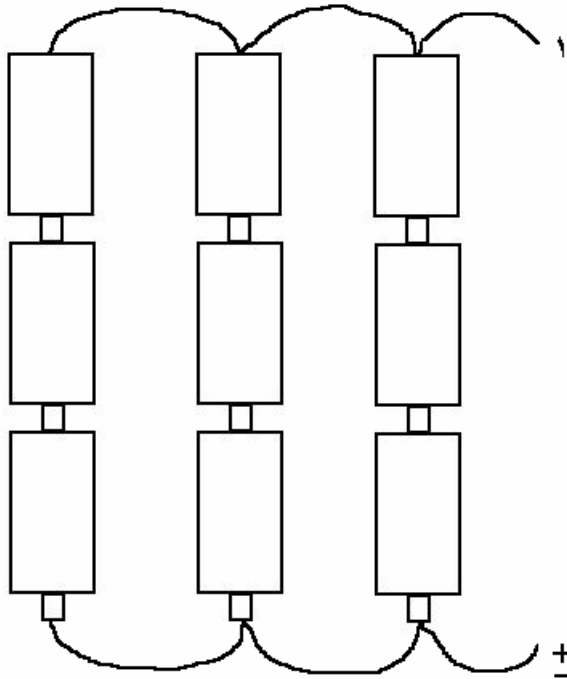

() (

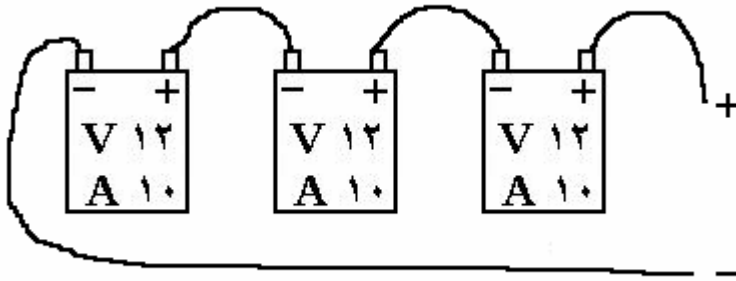

= + + =

()

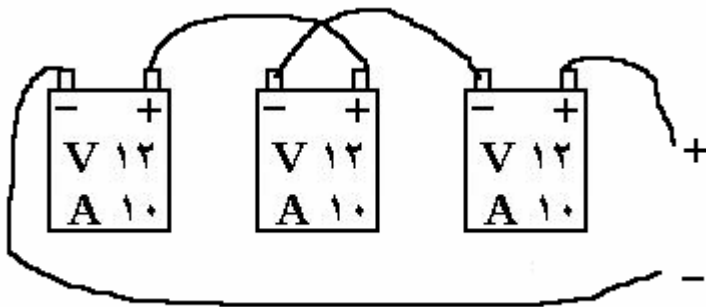

= + =

()

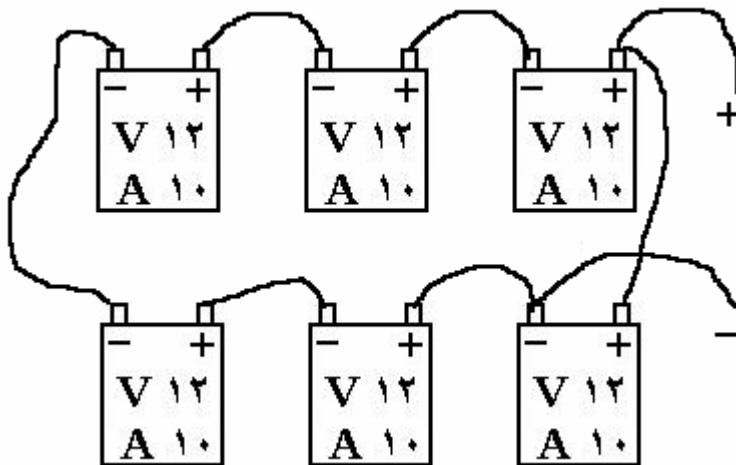

(-)

AC

.()

. (-)

. (-)

(-)

(,)

:

()

$$+ + =$$

:

:

- = ■
- = ■
- = ■
- = ■
- = ■

$$) \times () = () :$$

(

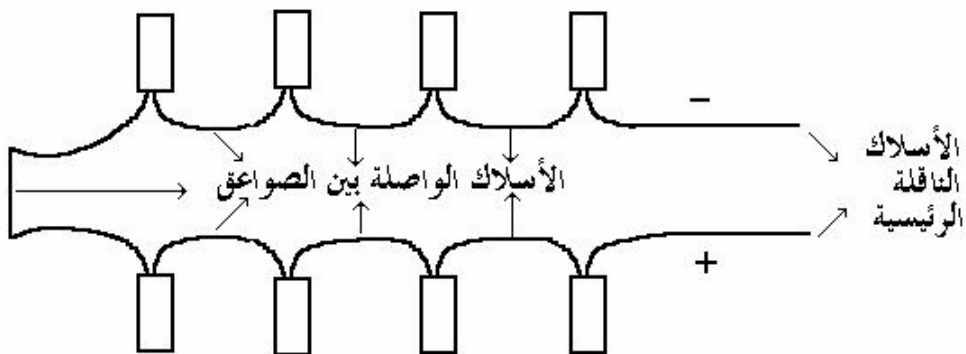

.()

: _____

: _____

.(+ + =)

$$= , \times (\div) = \quad \blacksquare$$

$$. , = , \times (\div) = \quad \blacksquare$$

$$= , \times = \quad \blacksquare$$

$$. , = + , + = \quad \blacksquare$$

$$= \quad \blacksquare$$

$$, = \times , = \quad \blacksquare$$

:

$$(\div) + + =$$

:

- = ■
- = ■
- = ■
- = ■

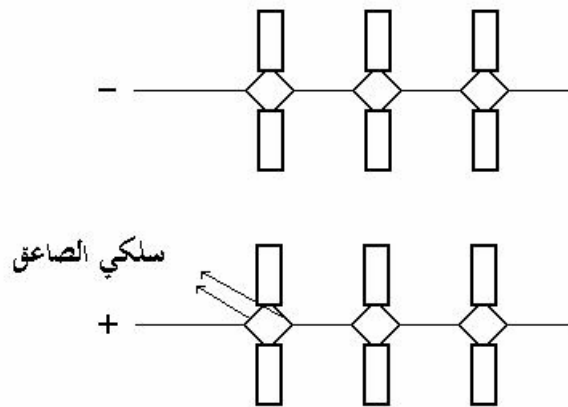

:

:

:

$$. = \times (\div) = \quad \blacksquare$$

$$. = \times (\div) = \quad \blacksquare$$

$$. , = \div (, \times) = \quad \blacksquare$$

:

$$, = , + + = \quad \blacksquare$$

$$= \quad \blacksquare$$

$$. = \times , \quad \blacksquare$$

:

$$[/ (+)] + = :$$

:

- = ■
- = ■
- = ■
- = ■

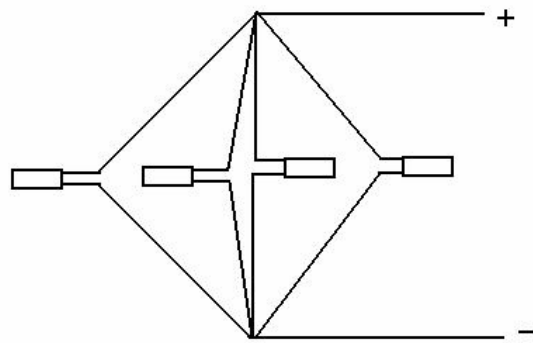

:

(
(
(

:

:

$$. = , \times (\div) = \quad \cdot$$

$$= \quad \cdot$$

$$. , = , \times (\div) =$$

$$, = \quad \cdot$$

$$. = \quad \cdot$$

$$. , = [/ (, + ,)] + = \quad \cdot$$

$$. = , \times = () , \times = \quad \cdot$$

$$. = \times = () \quad \cdot$$

.

:

:

$$[/ (+)] + =$$

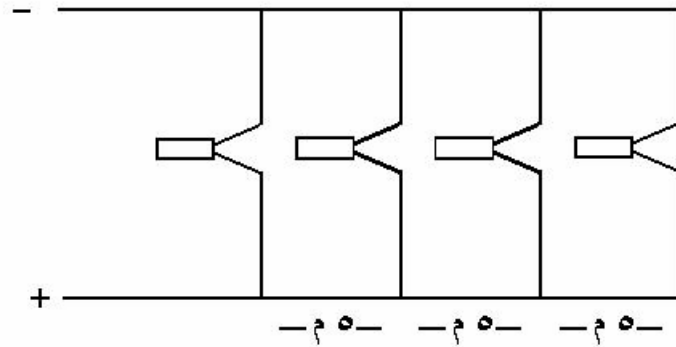

:

(
 .()
 .
 .
 .
 .

(-) :

$$[/ (+)] + = :$$

:

= ■

= ■

= ■

= ■

:

.()

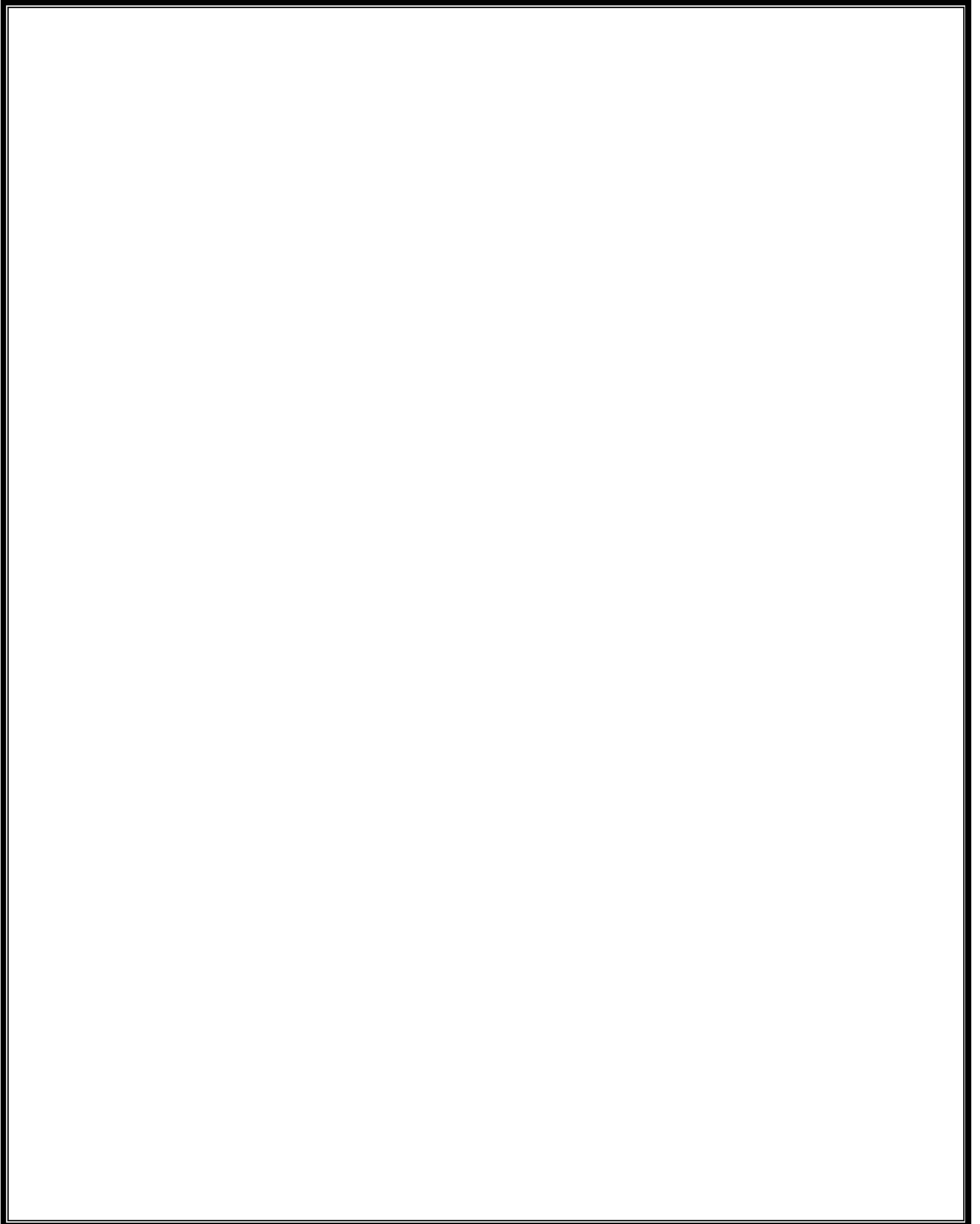

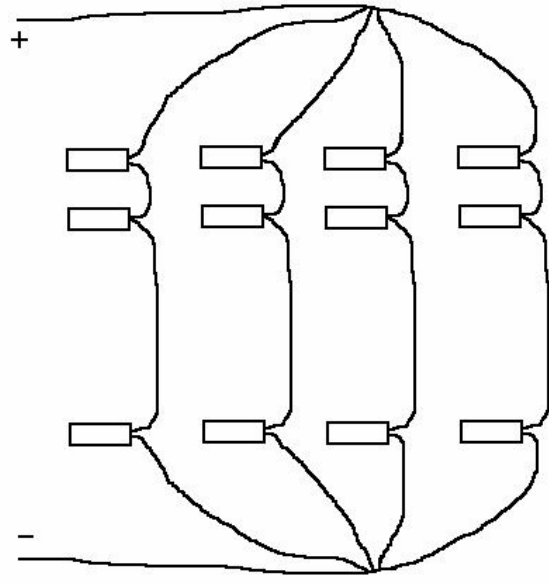

- $\cdot = \times (\div) =$
- $\cdot , = \times (\div) =$
- $\cdot , = , \times =$
- $=$
- $= [\div (, + ,)] + =$
- $= (\times) \times = ()$
-

دائرة
مختلطة

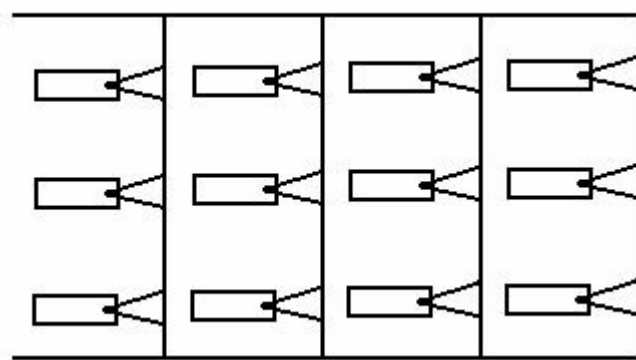

:

:

(
(
(
(

(
(
(
(
(
(

× =

(
(

()

(-)

()

()

()

.

.

.(% -)

.

-

-

.

()

.

.

.

:

.

.

.

(

(

(

(

(

(

(

(

(

(

(

(

() .

(

:

(

(

(

(

(

(J.2)

(

(

:

.

.

.

.

.

.

.

.

.

.

.

.

(
(
(
(

(
(

(
(

(

(
(
(
(

:

()

)

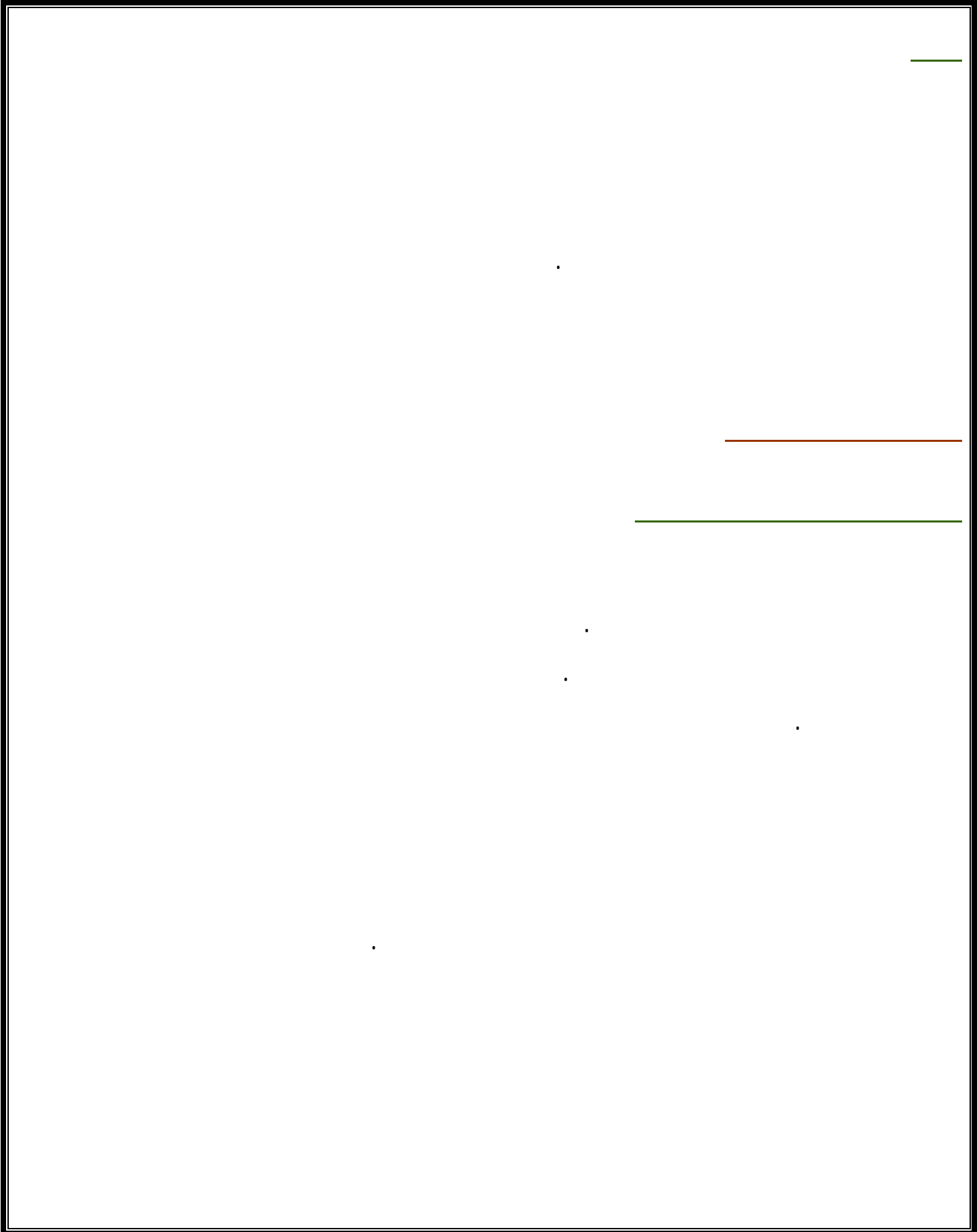

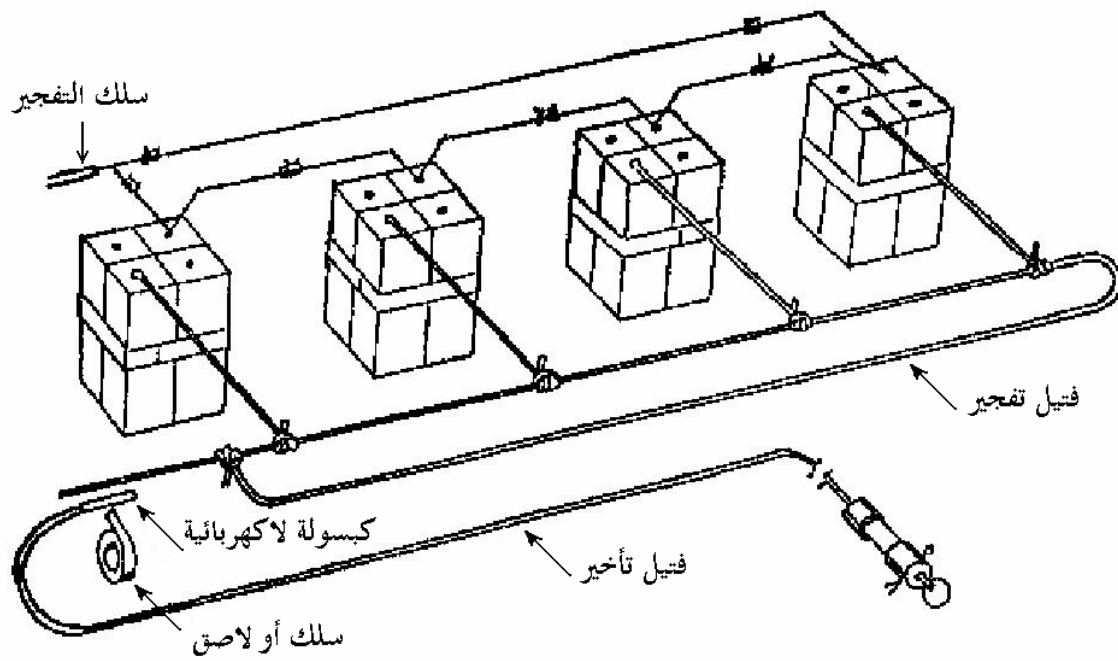
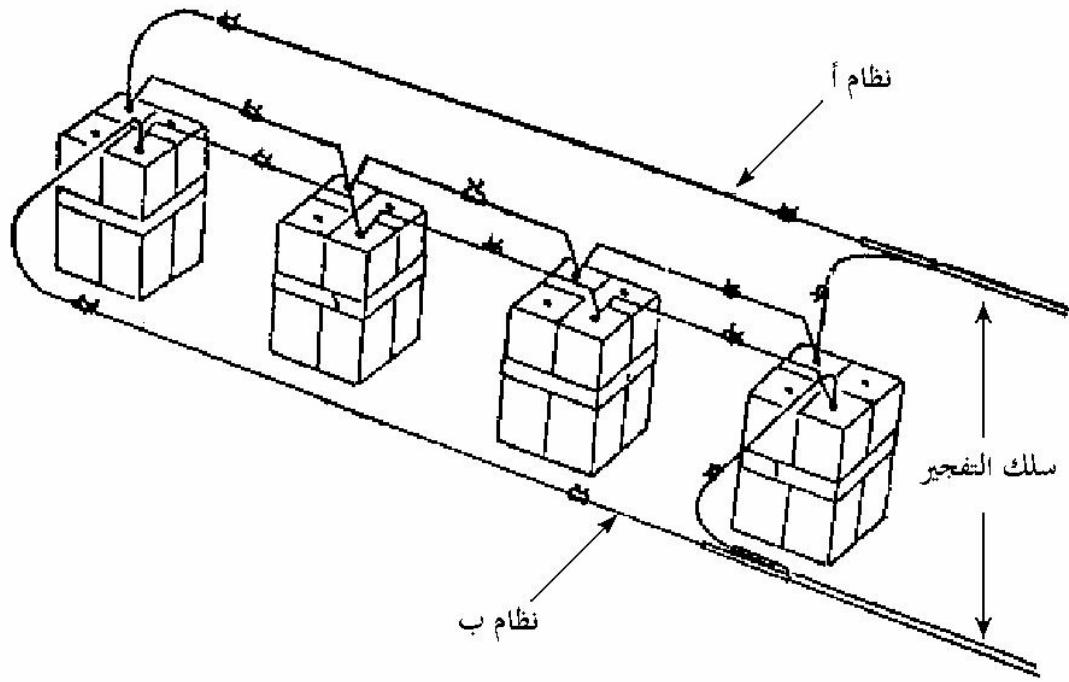

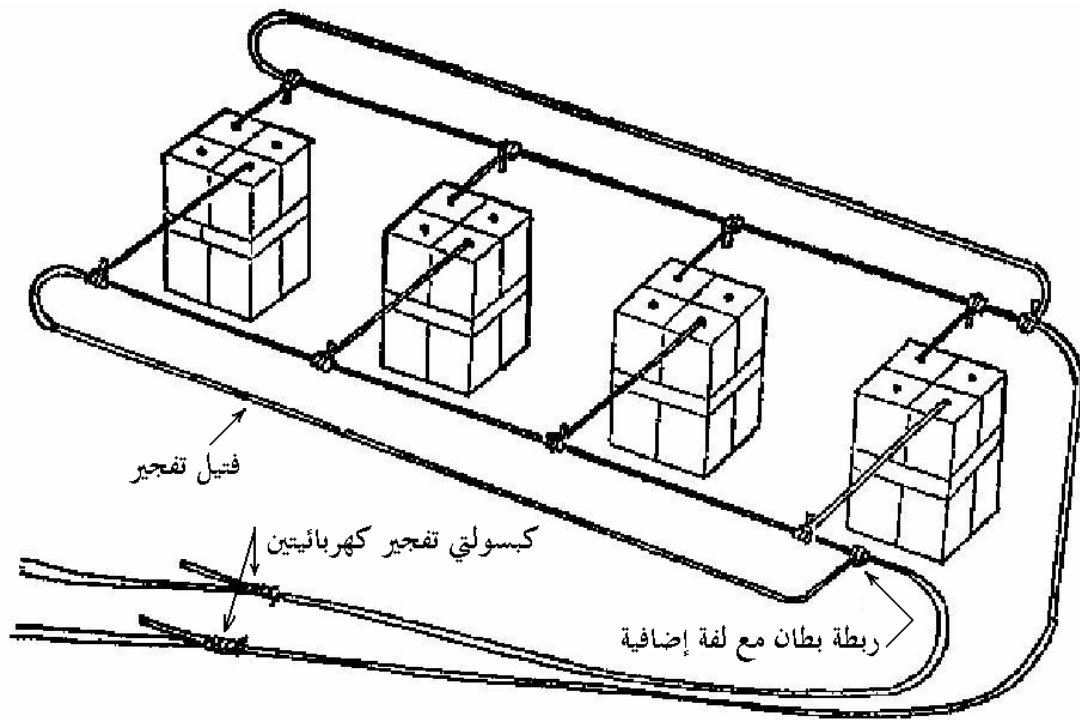
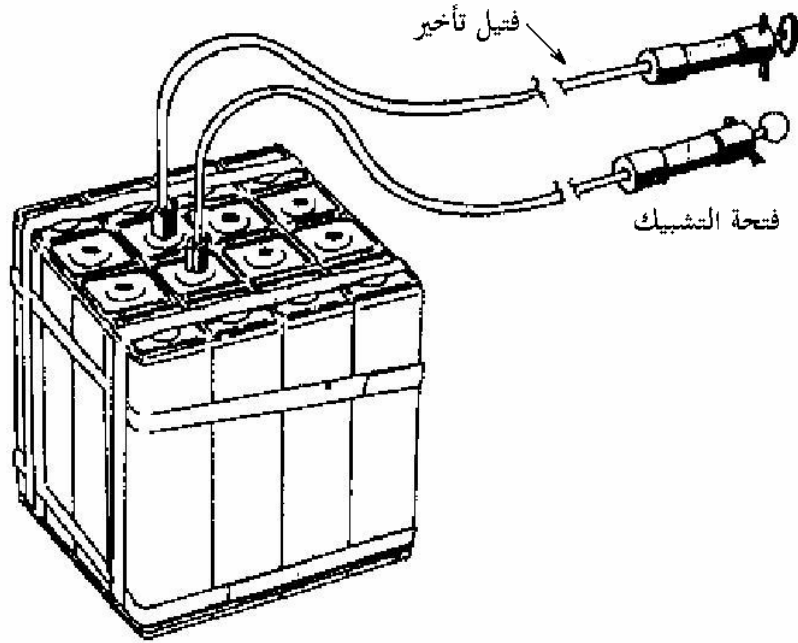

(

:

-
-
-
-

:

-

M5 M1 :

.

.

-

()

.

.

:

-

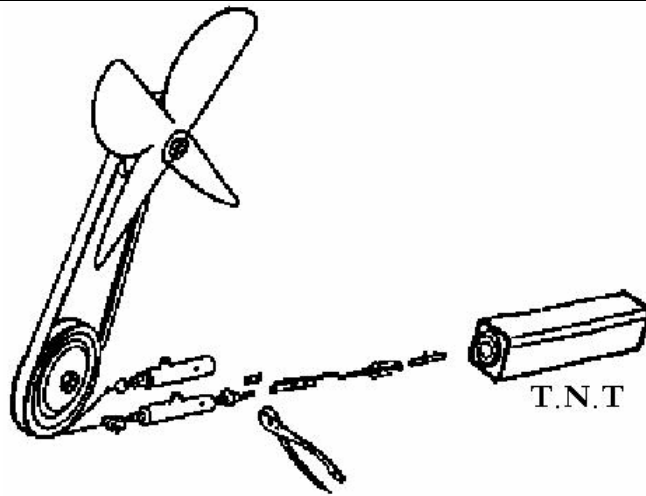

(

(

(

(

(

(

()

(

()

()

(

(

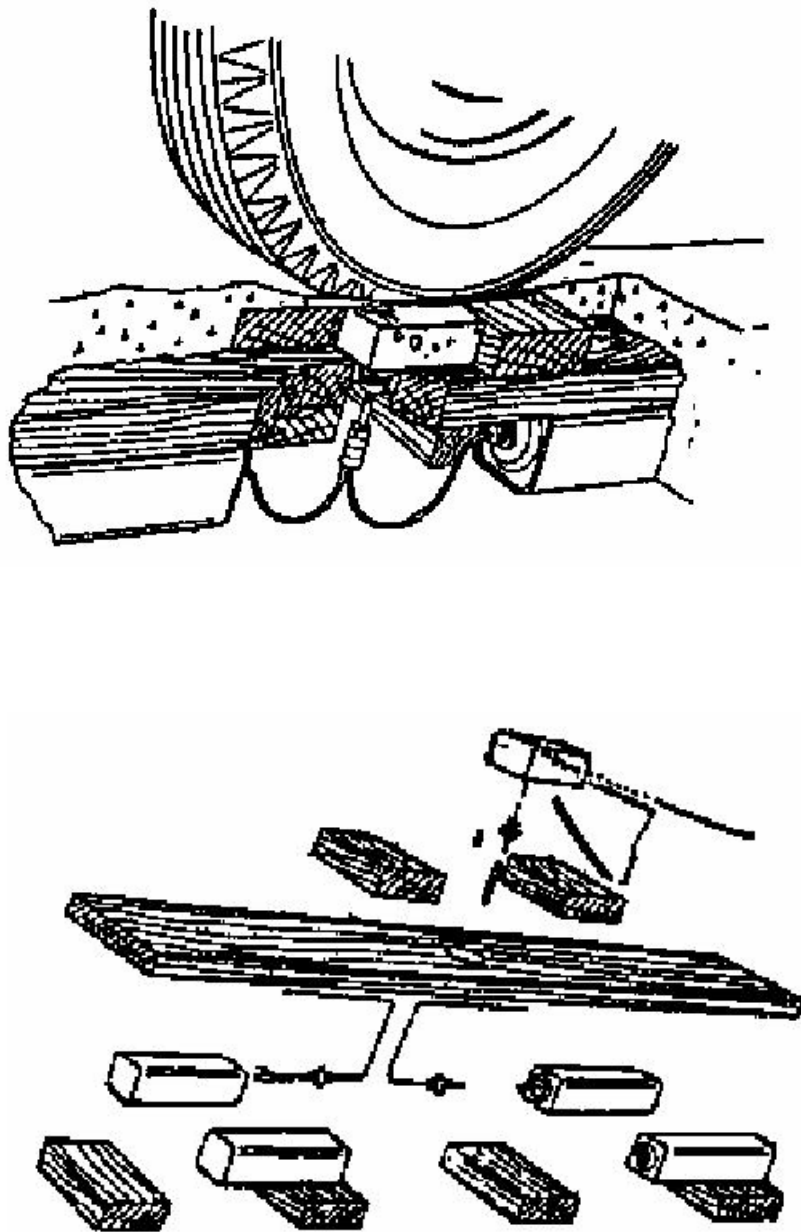

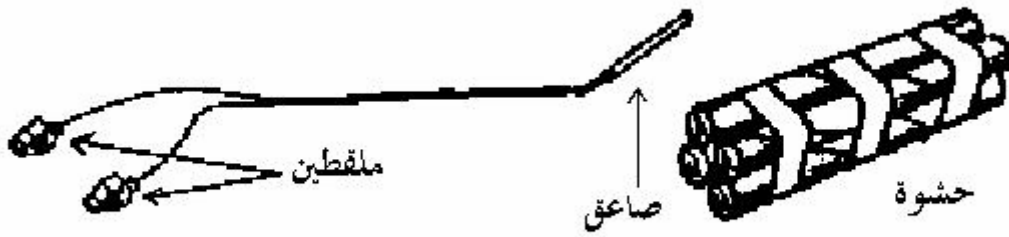

(

(
(
(

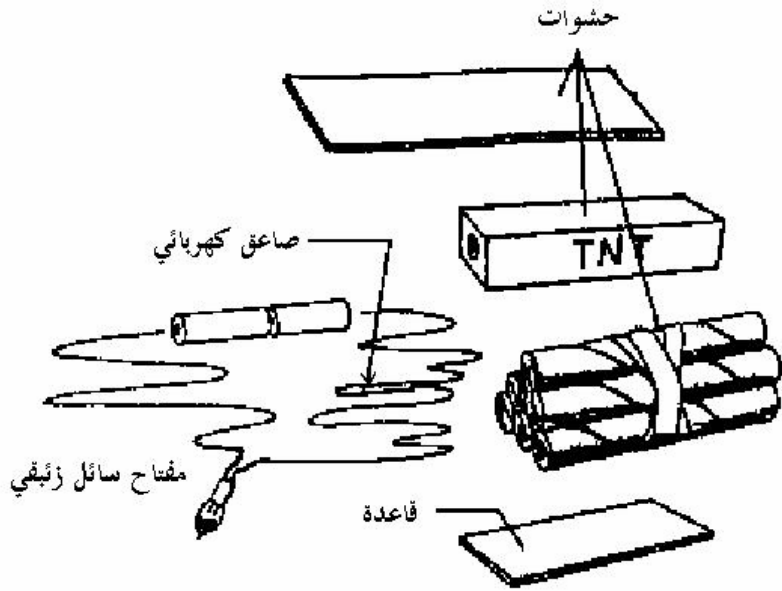

:
(
(

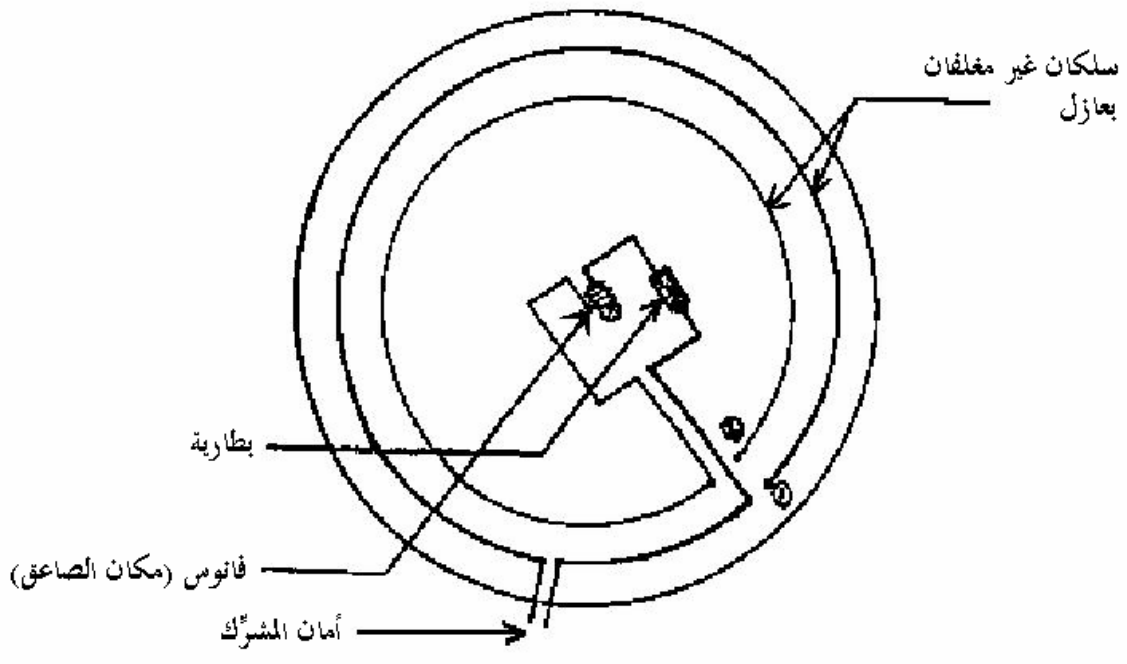
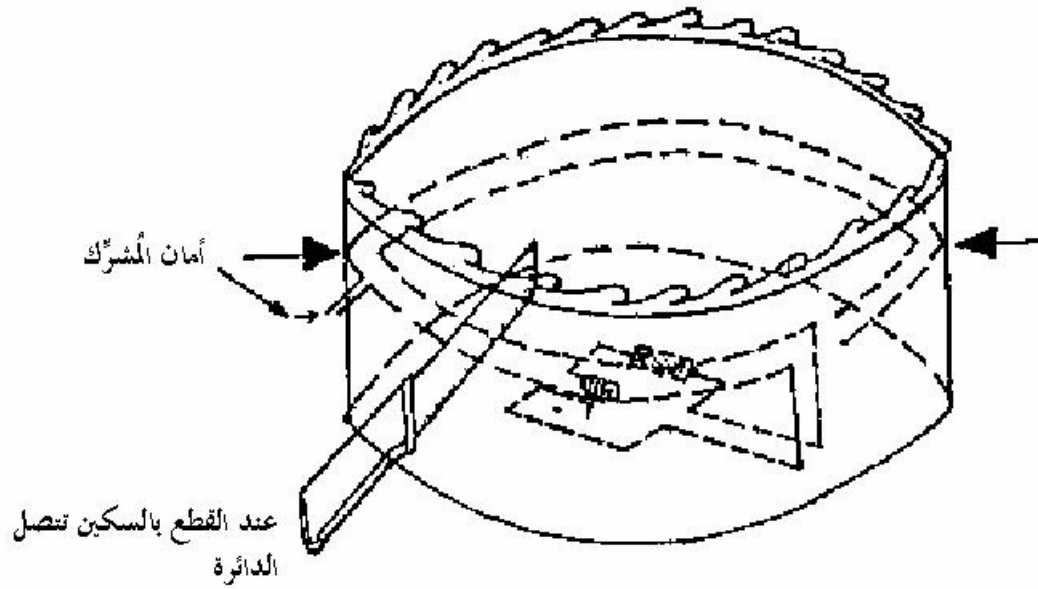

()

()

)

(

()

.()

:

()

▪

▪

-
-

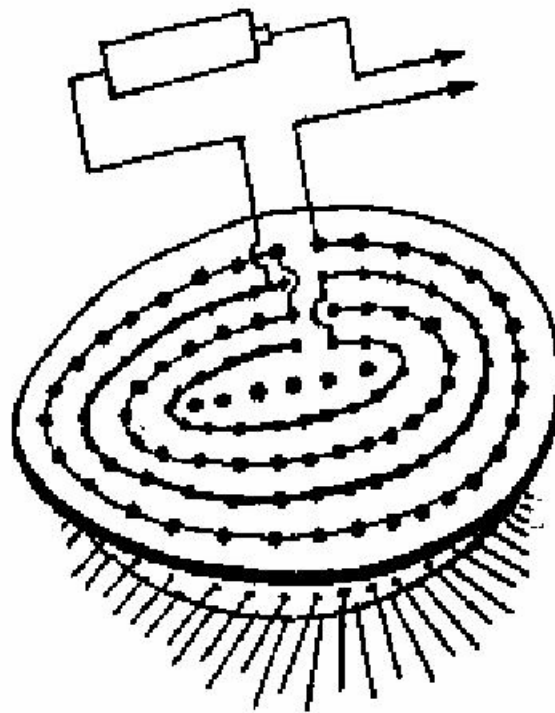
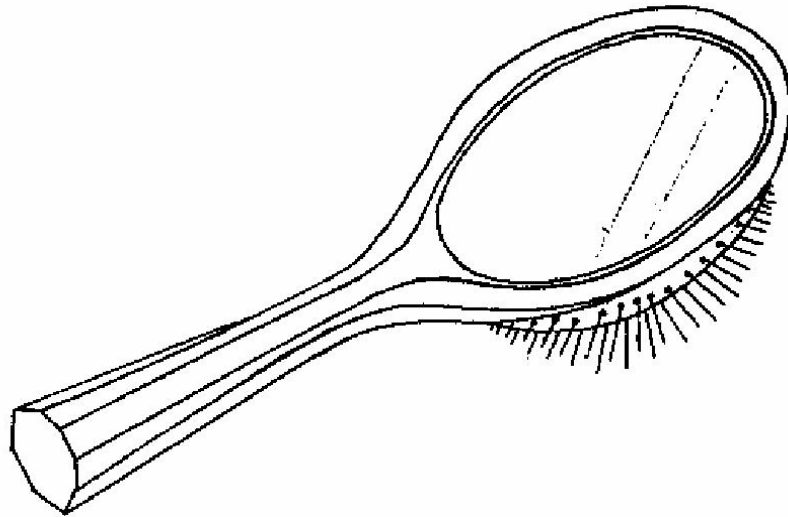

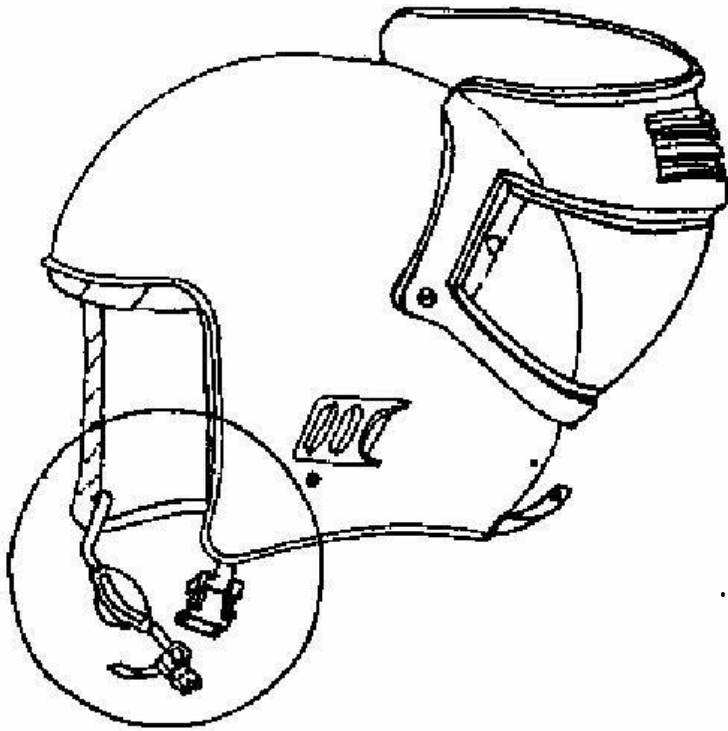

رسم (١)

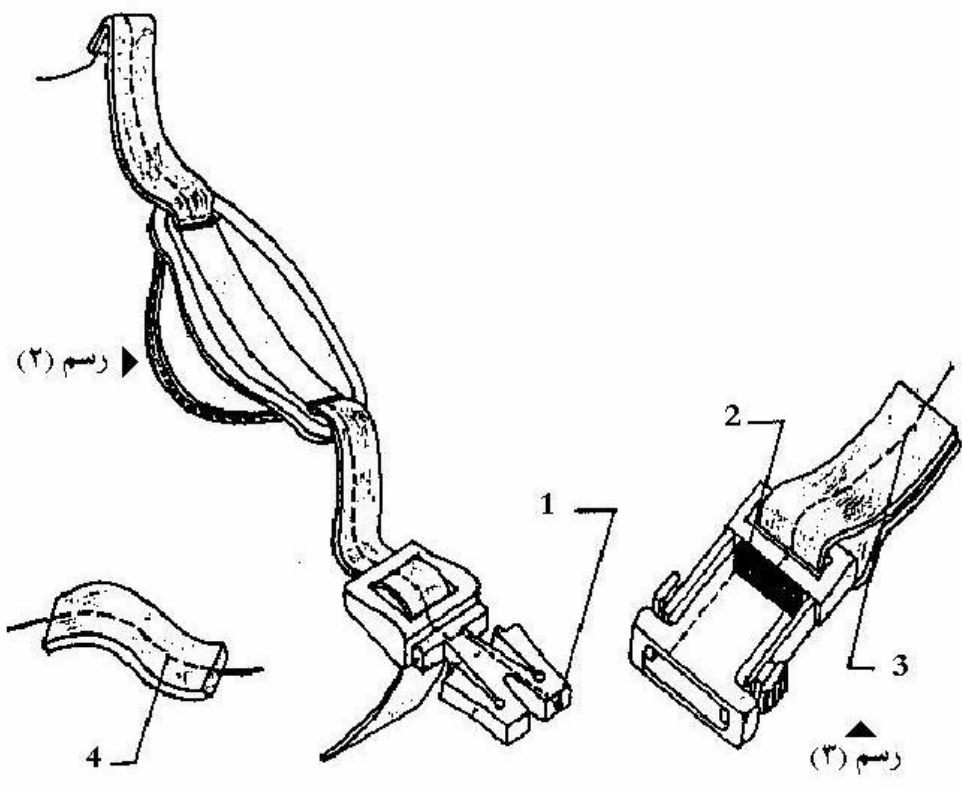

(

(

(

(

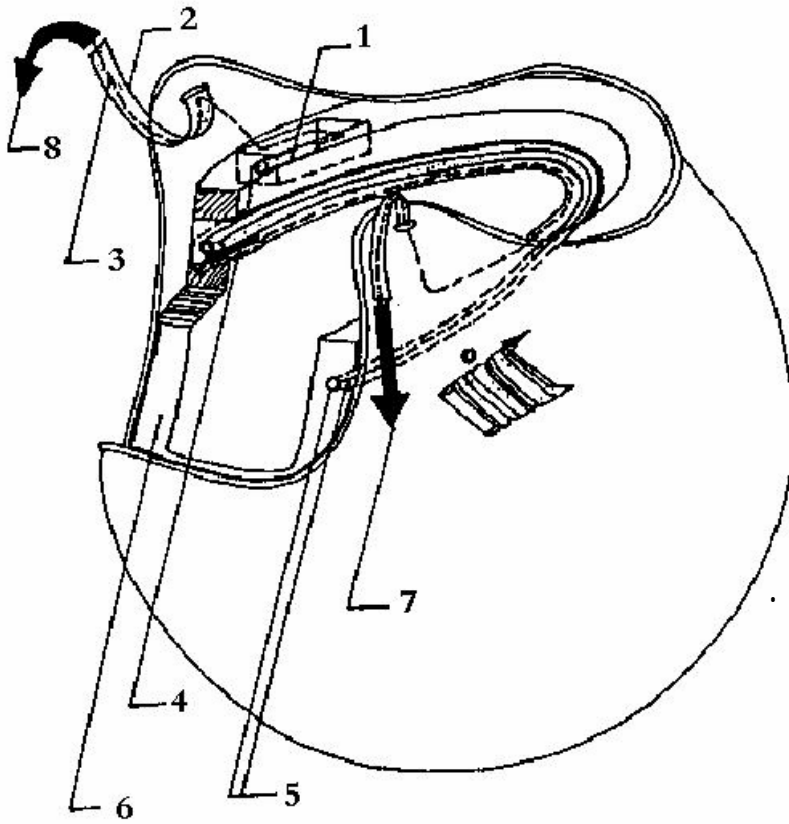

_____ :

(
(

(
(
(
(

()

(
(

()

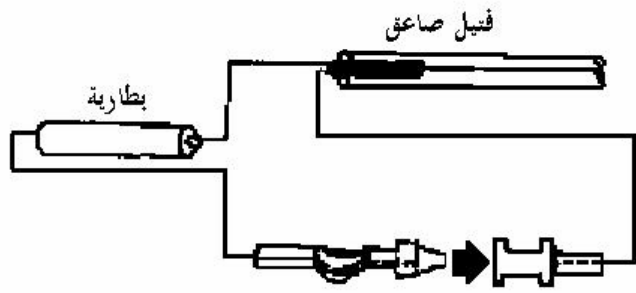

رسم للدائرة الكهربائية

_____ (

.()

()

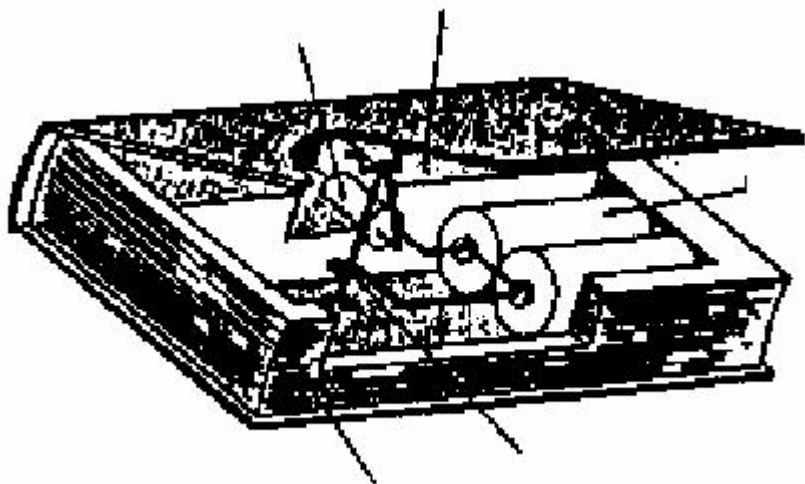

(

)

(

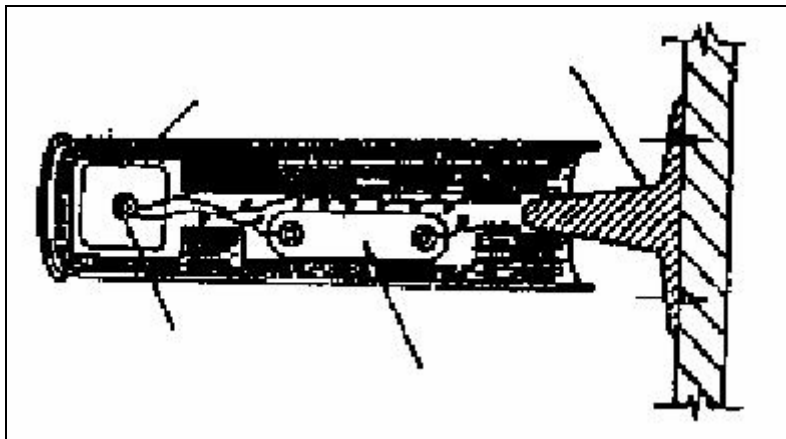

{يوجد هنا صفحتان مفقودتان}

_____ :

- (
- (
- (
- (
- (
- (

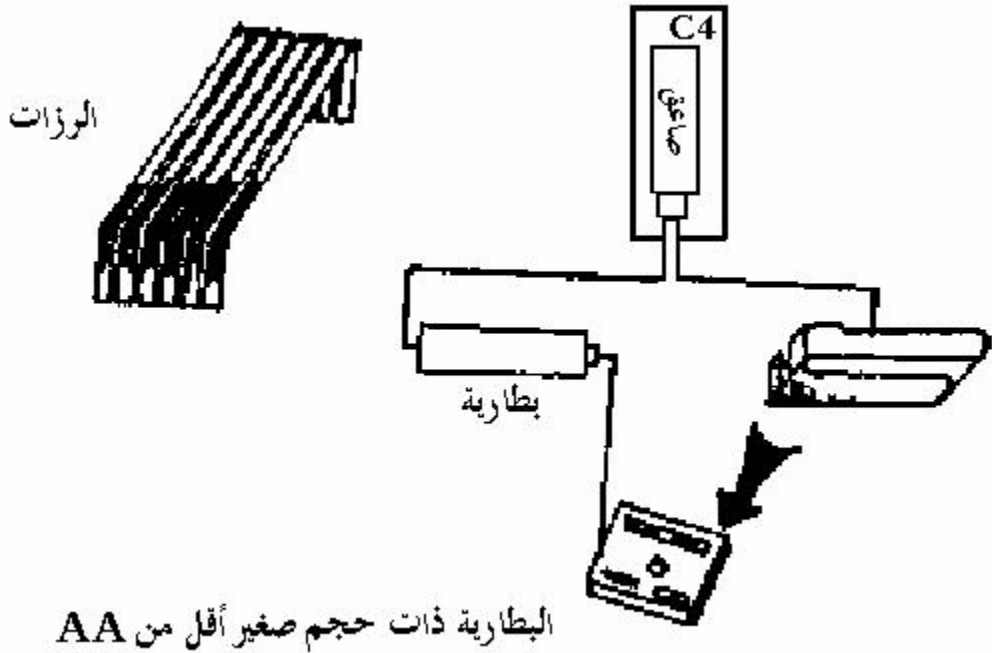

_____ :

() ()

()

() ()

()

()

()

()

()

()

()

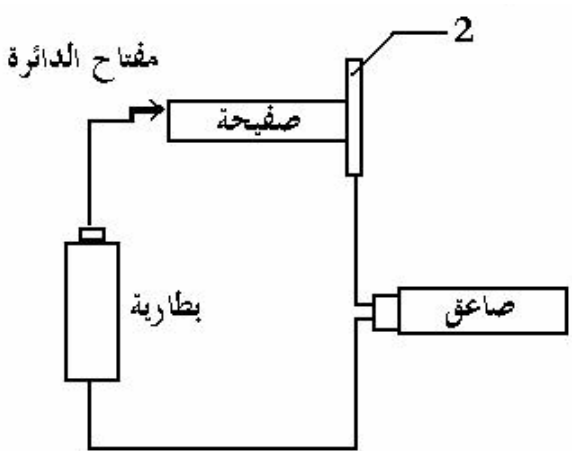

رسم (١)



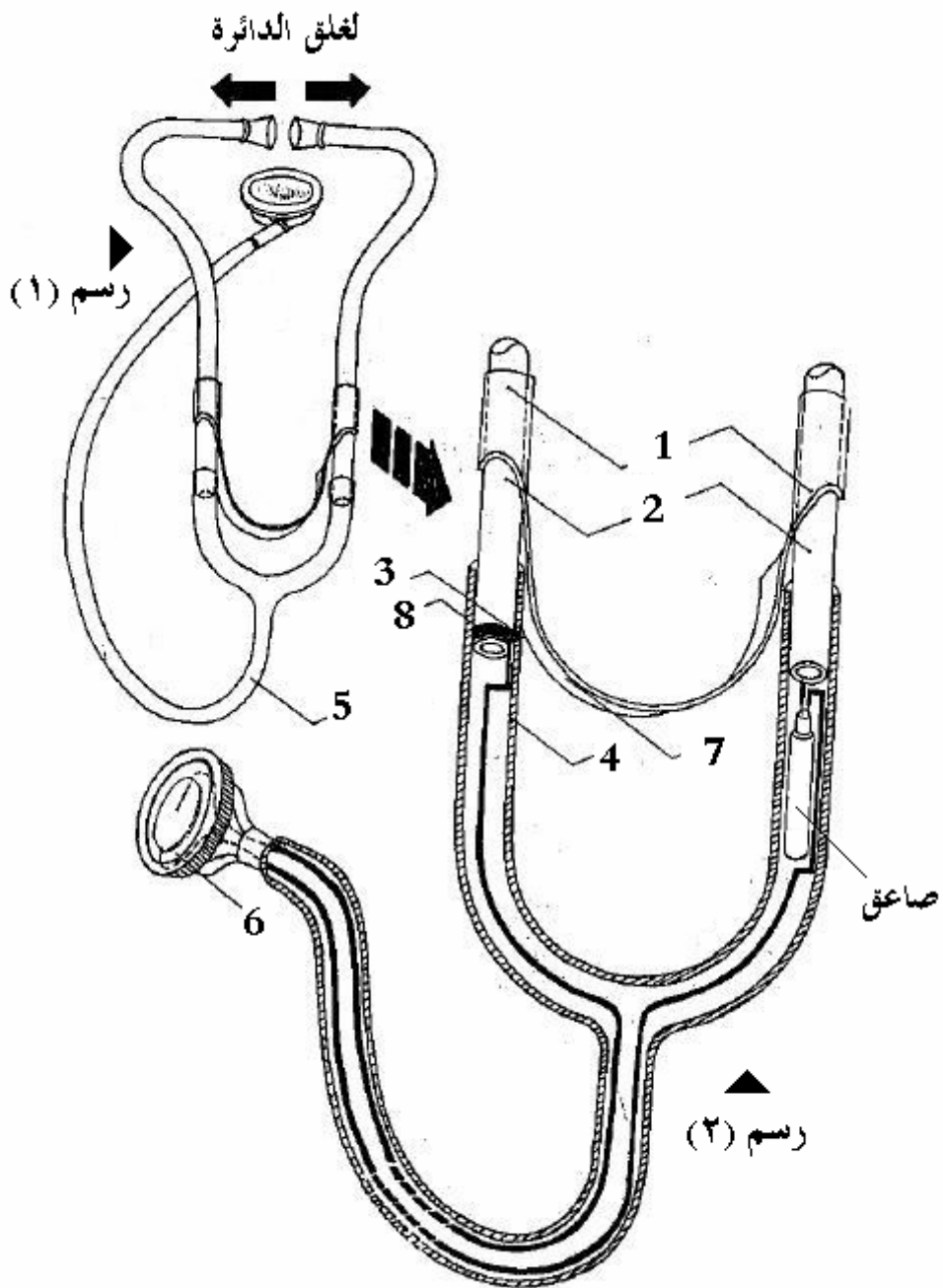

- (
- (
- (
- (
- (
- (
- (
- (
- (
- (

- (-)
- (+)
- (C4)
- (C4)

رسم (١)

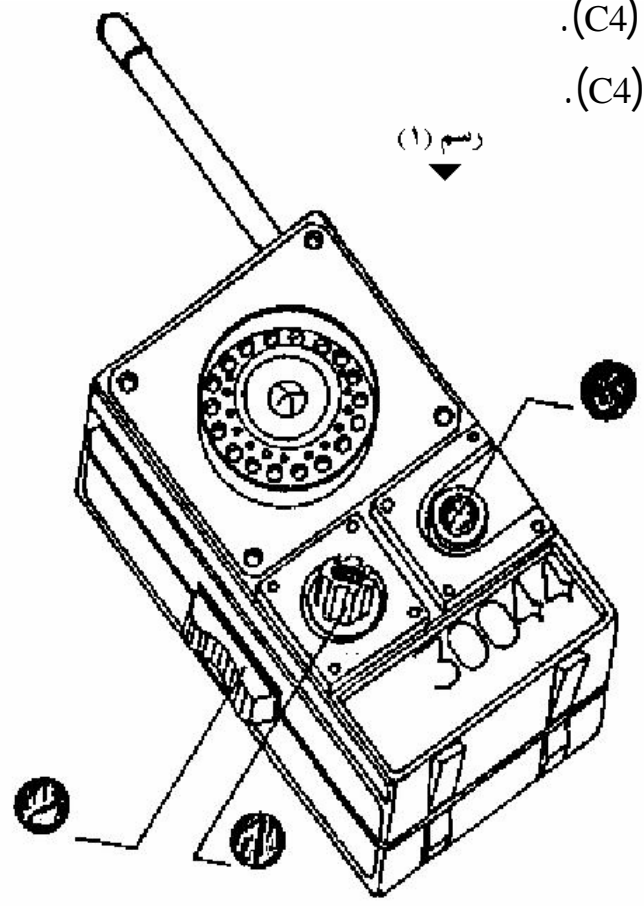

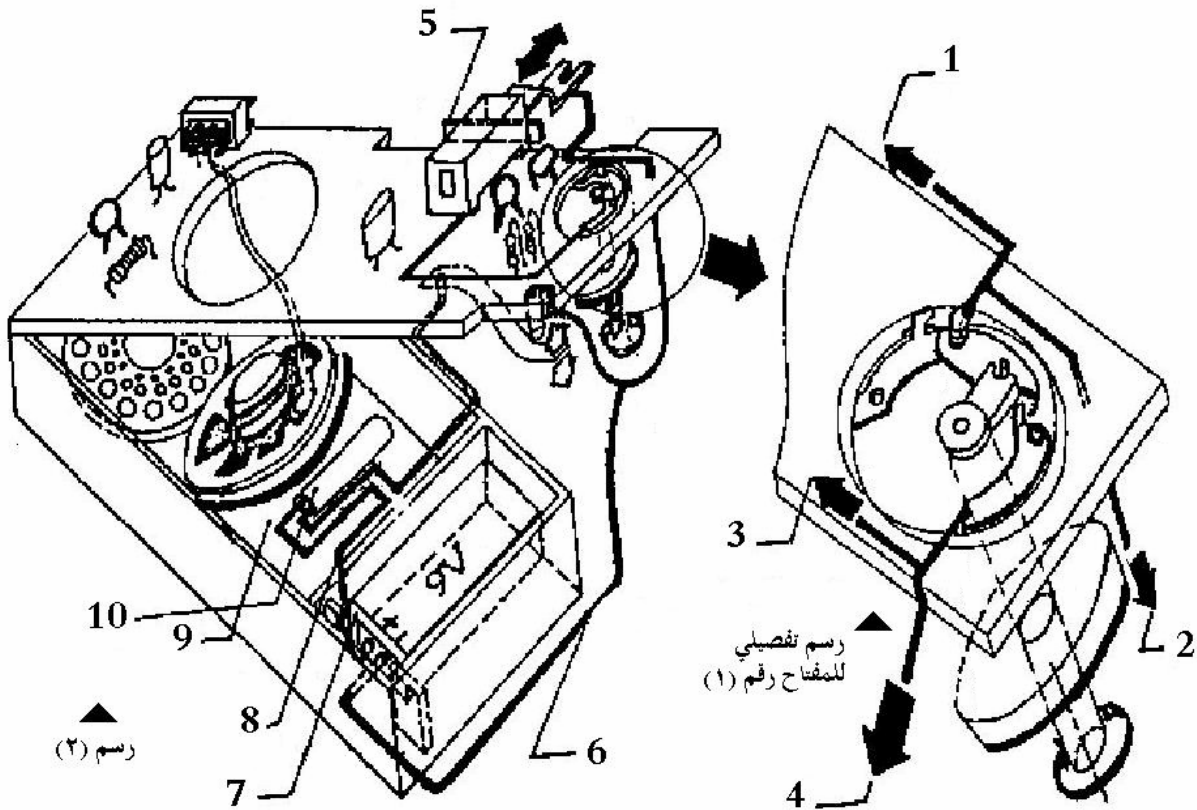

- (.
- (.
- ((.
- (.
- (.

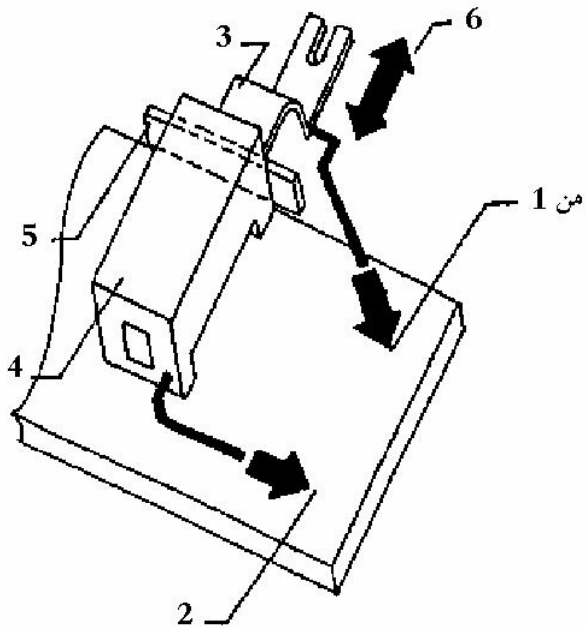

(
(
(

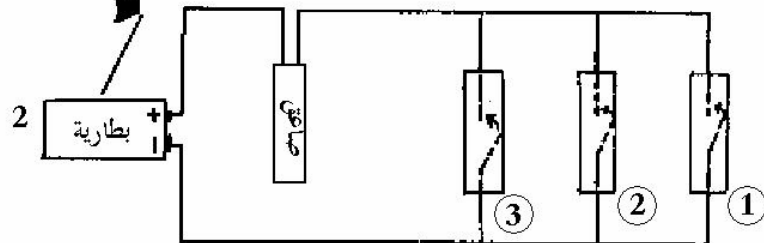
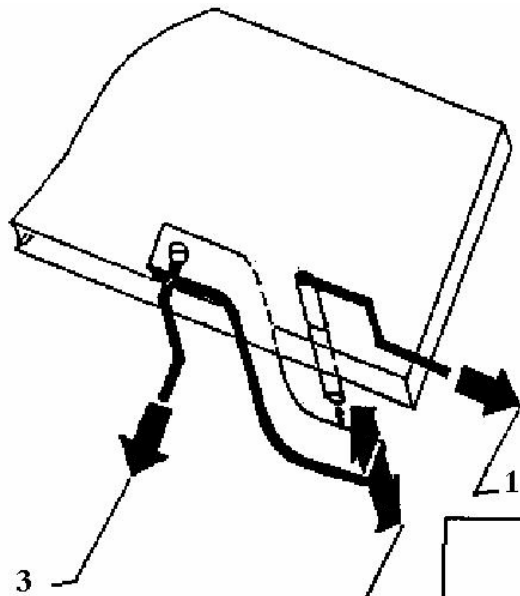

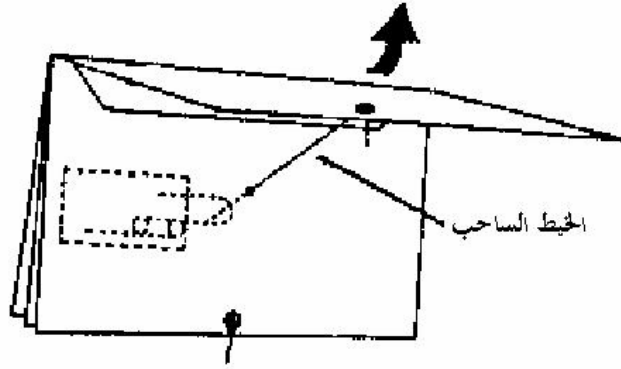

)

(

(

(

(

(

()

(

(

(

(

(

(

(

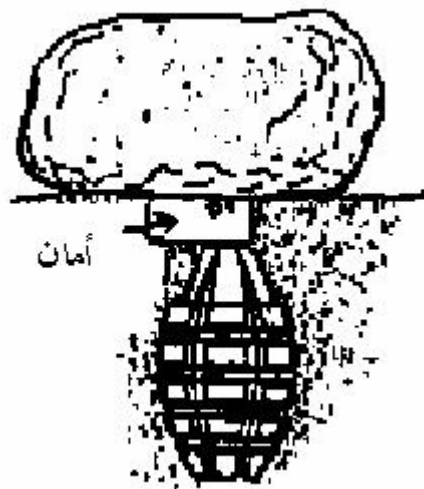
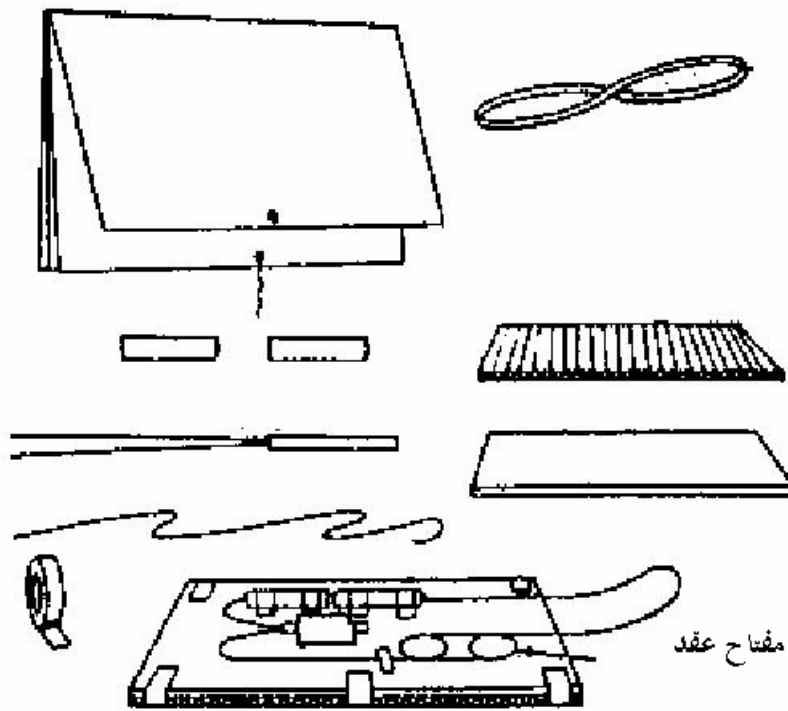

(-)

:

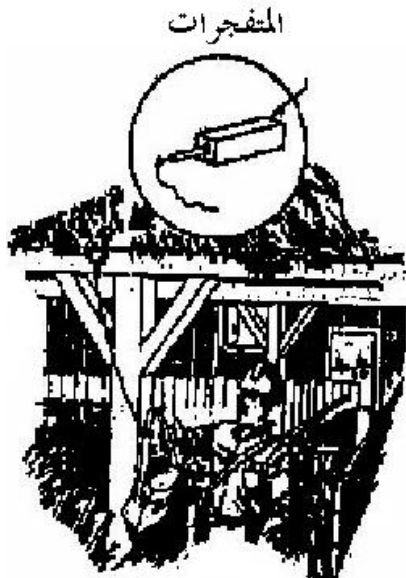
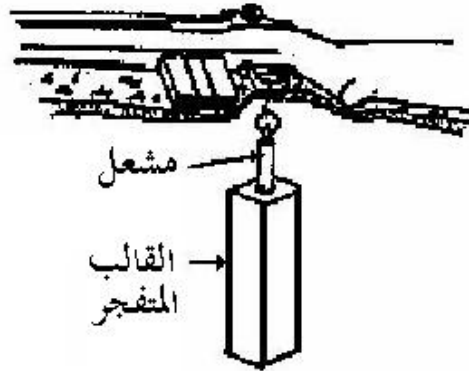

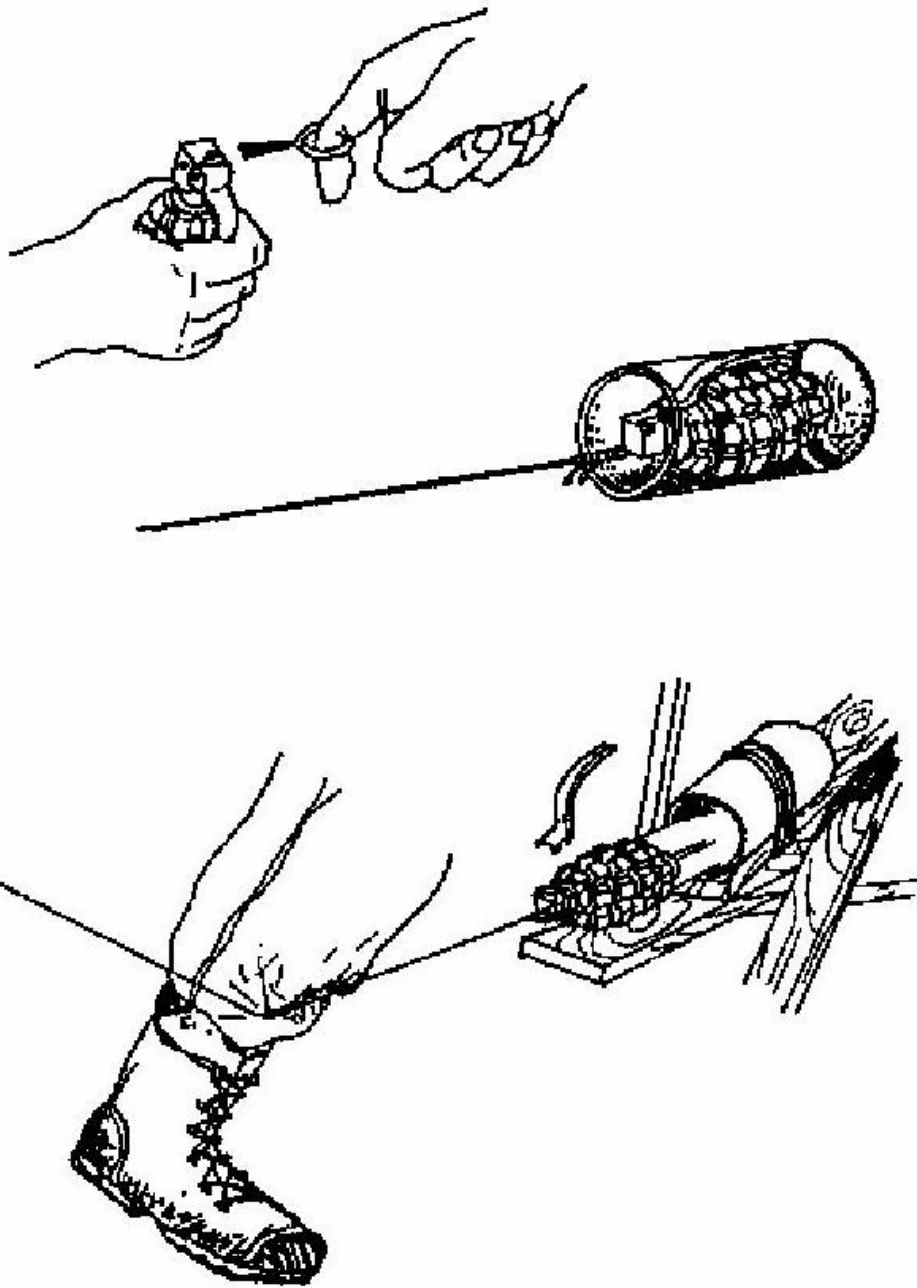

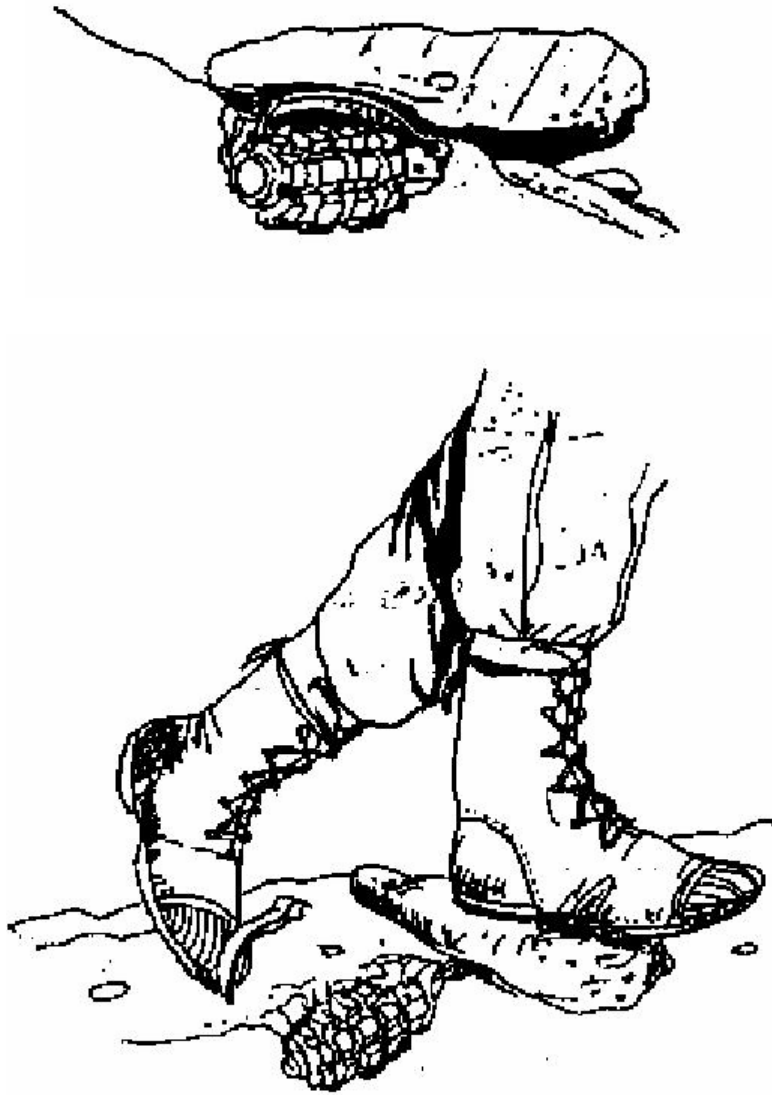

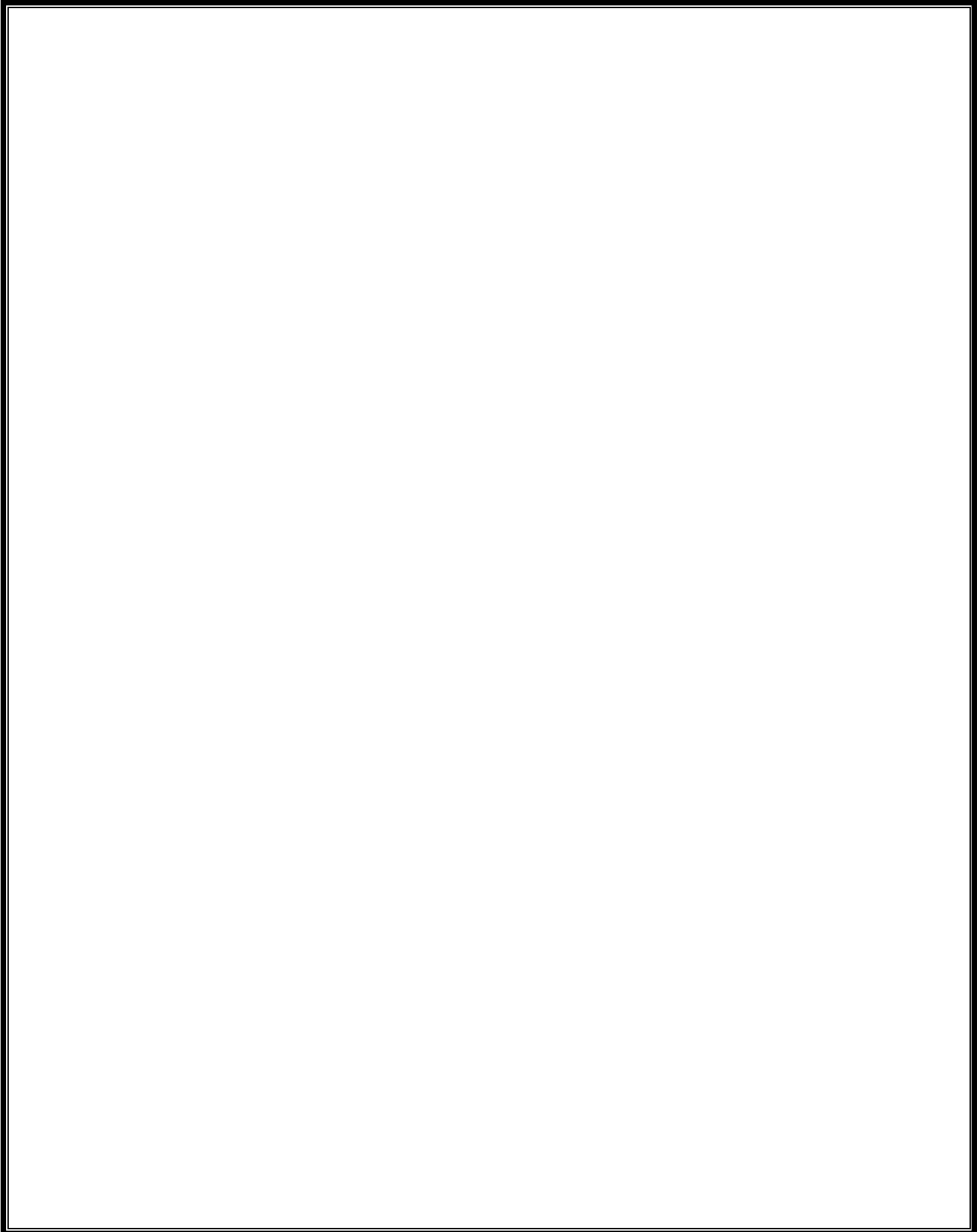

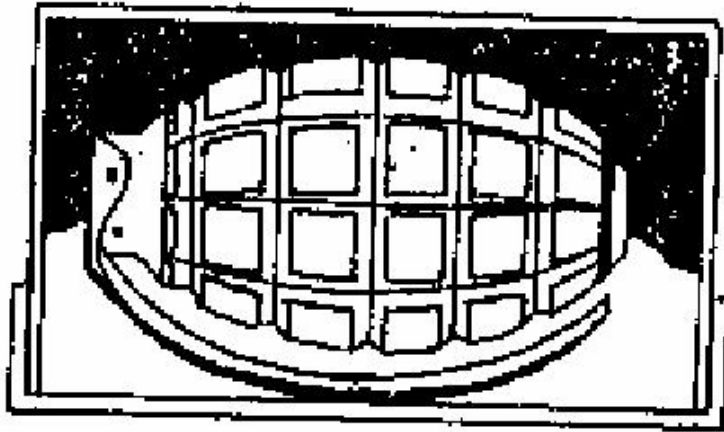

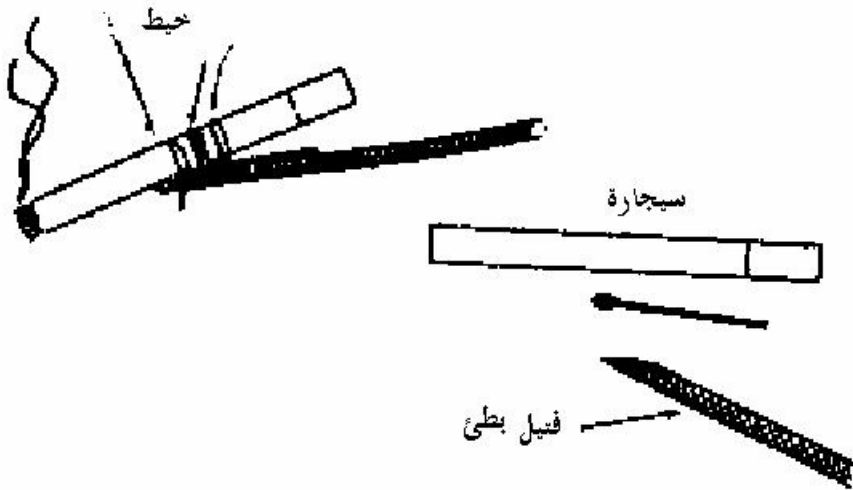

_____ :

_____ :

) (

.(

(

(

: (

(

(

(

(

(

(

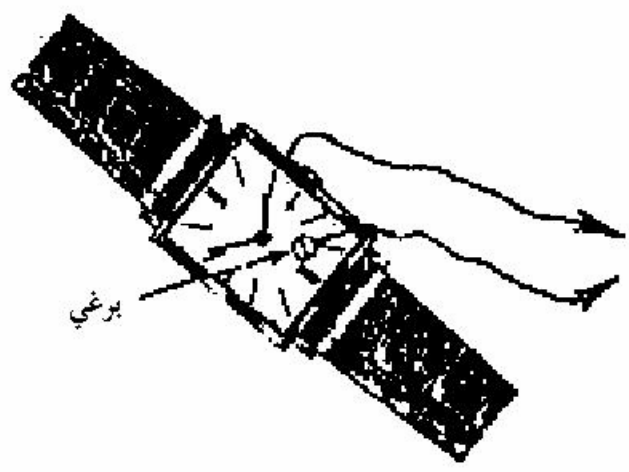

.GRASS HOPPER FUSE

()

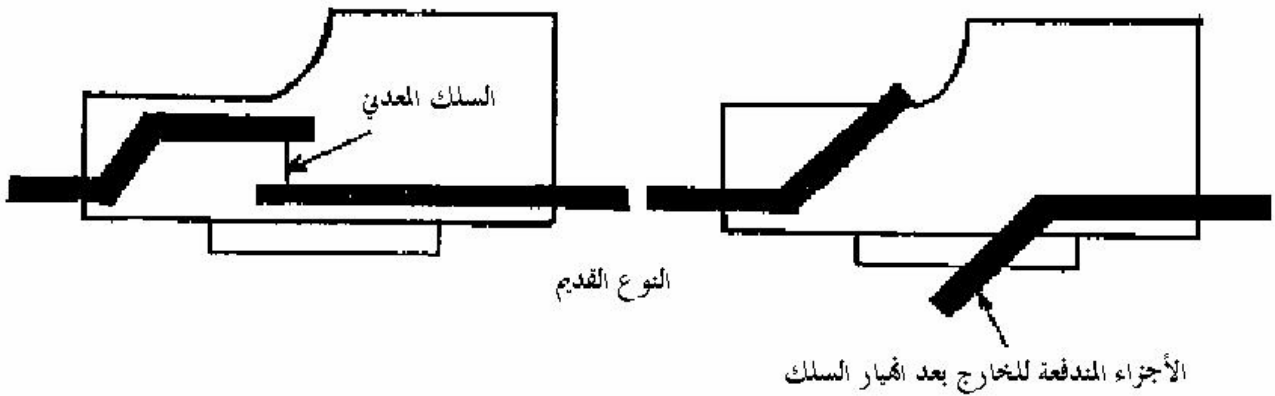

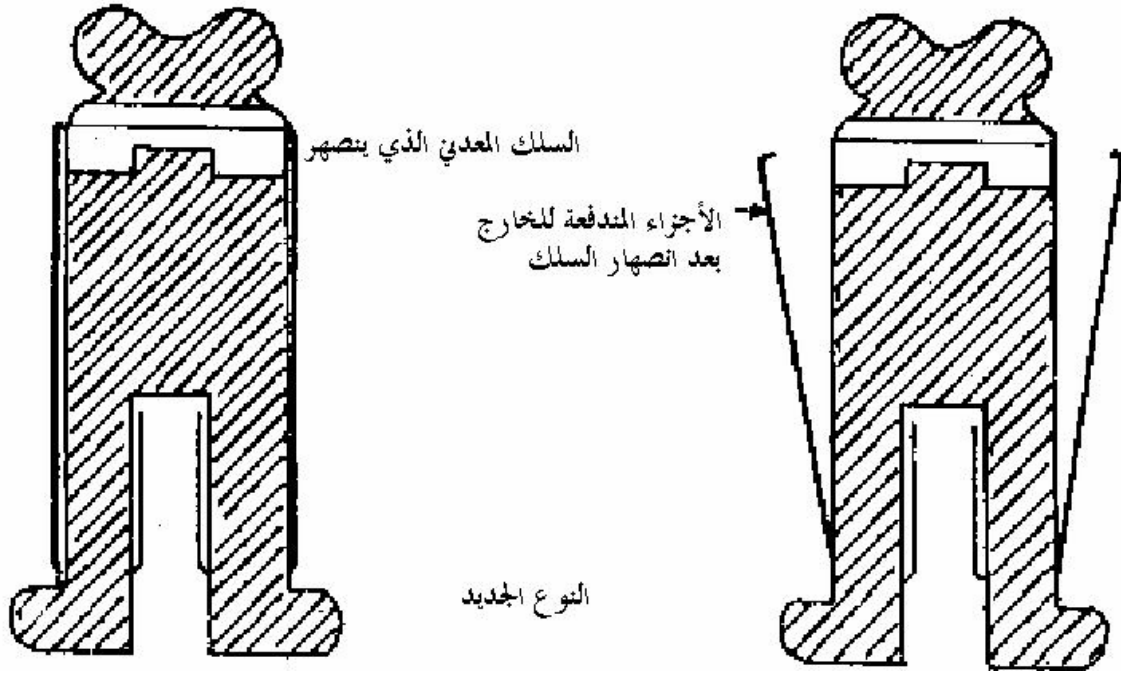

()

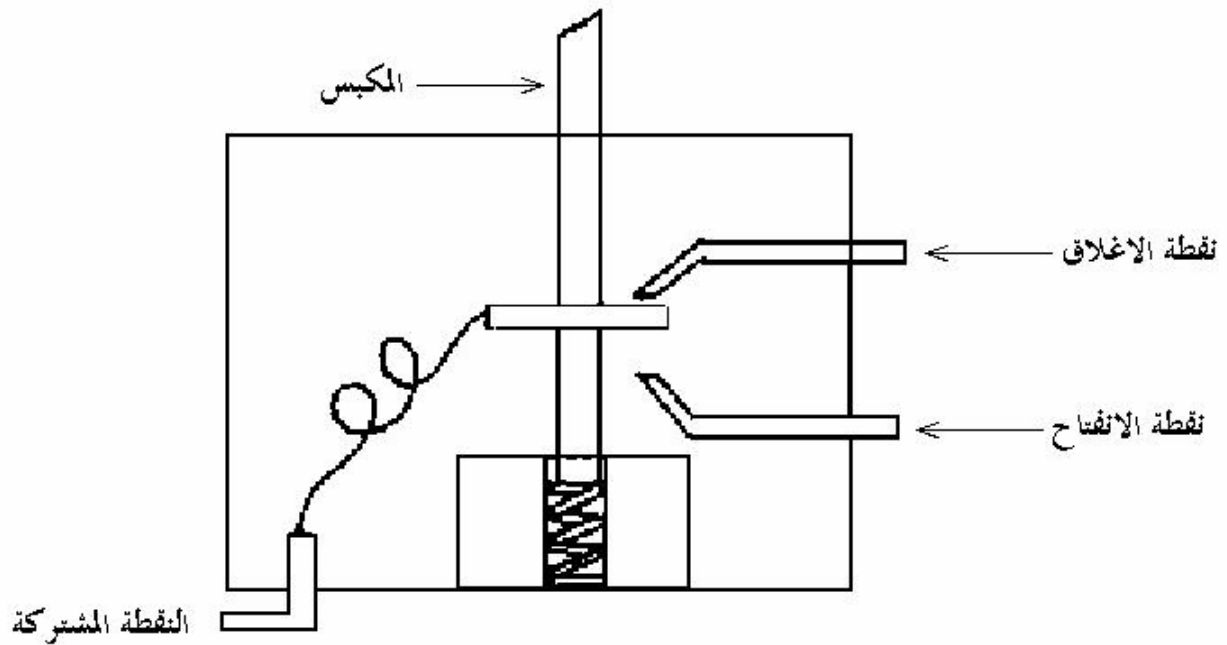

()

:

()

()

: (

: (

(

()

)

(

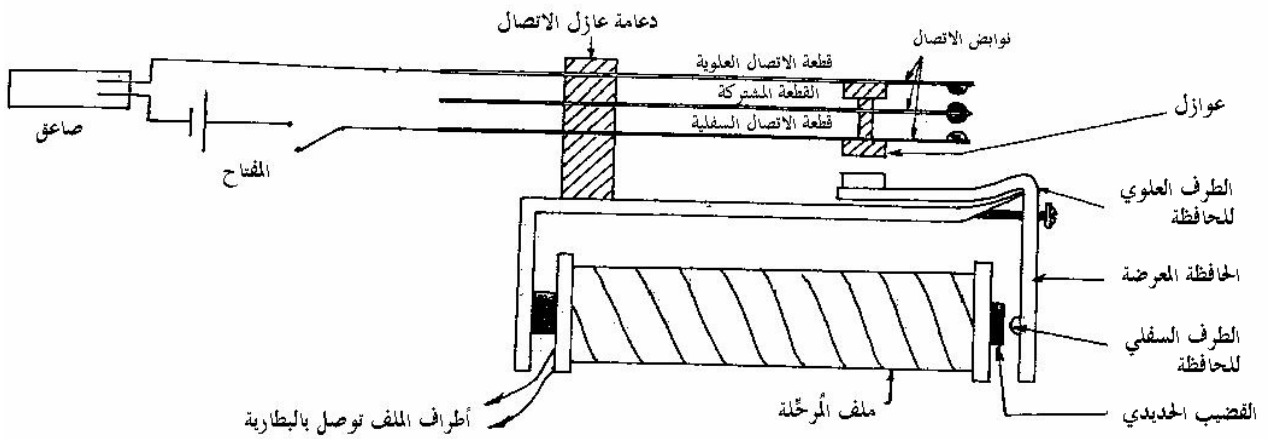

()

(

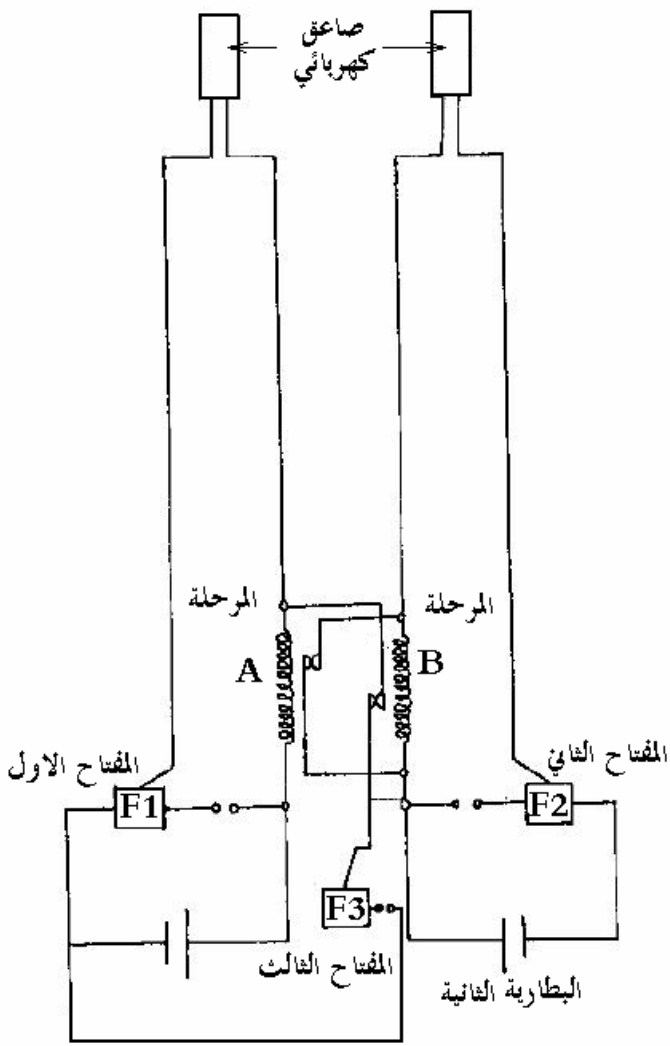
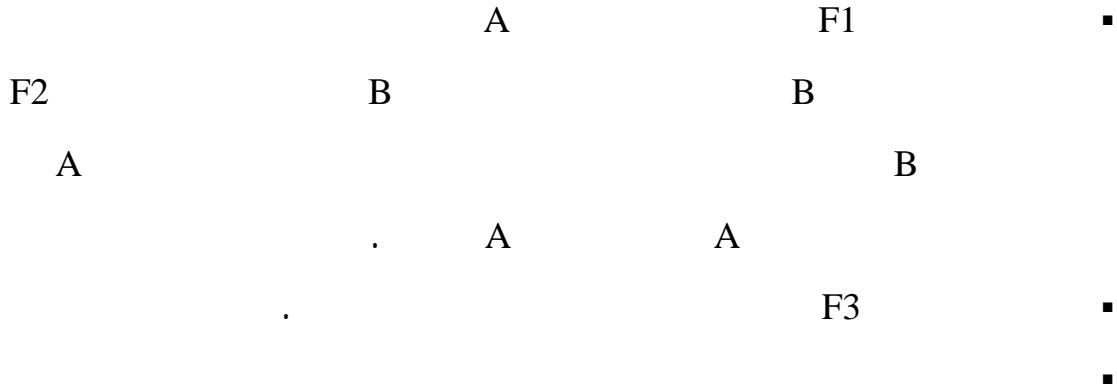

(

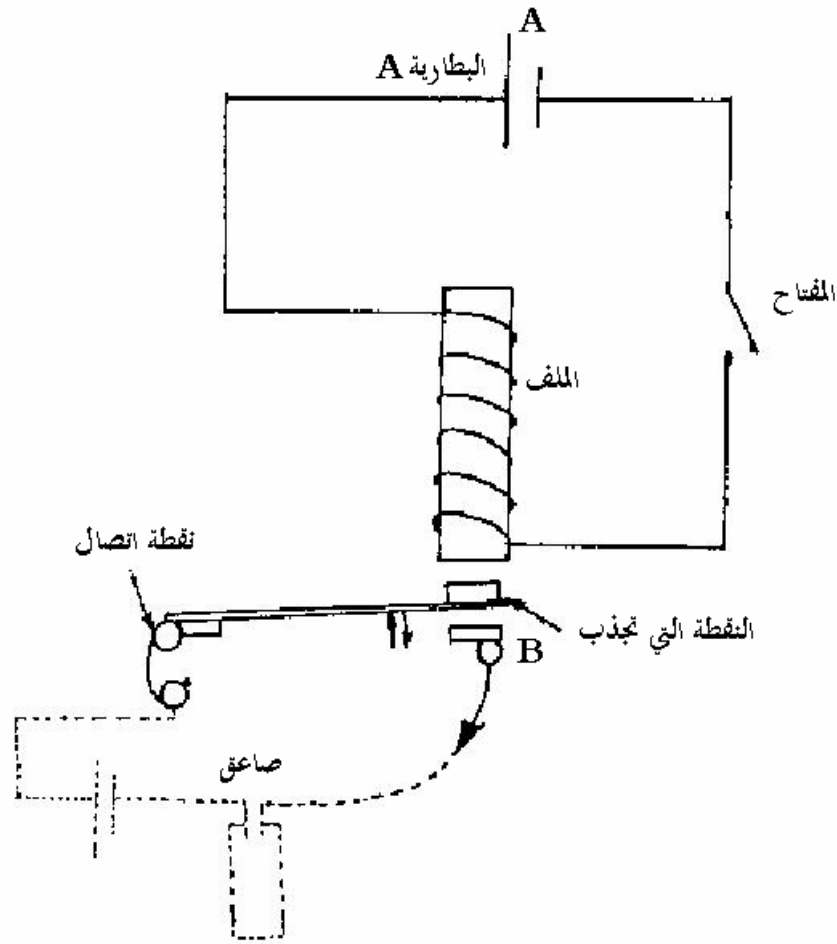

A

B

B

(

:

(

. ()

(S-S)

(

B A

(

C A

(S-S) B

A

(

C

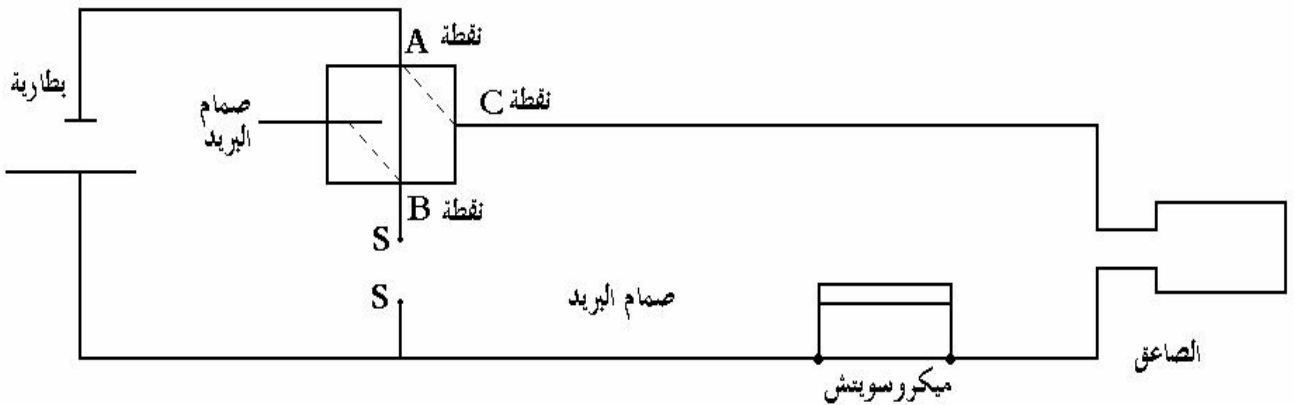

(

:

A

B

C

D

C

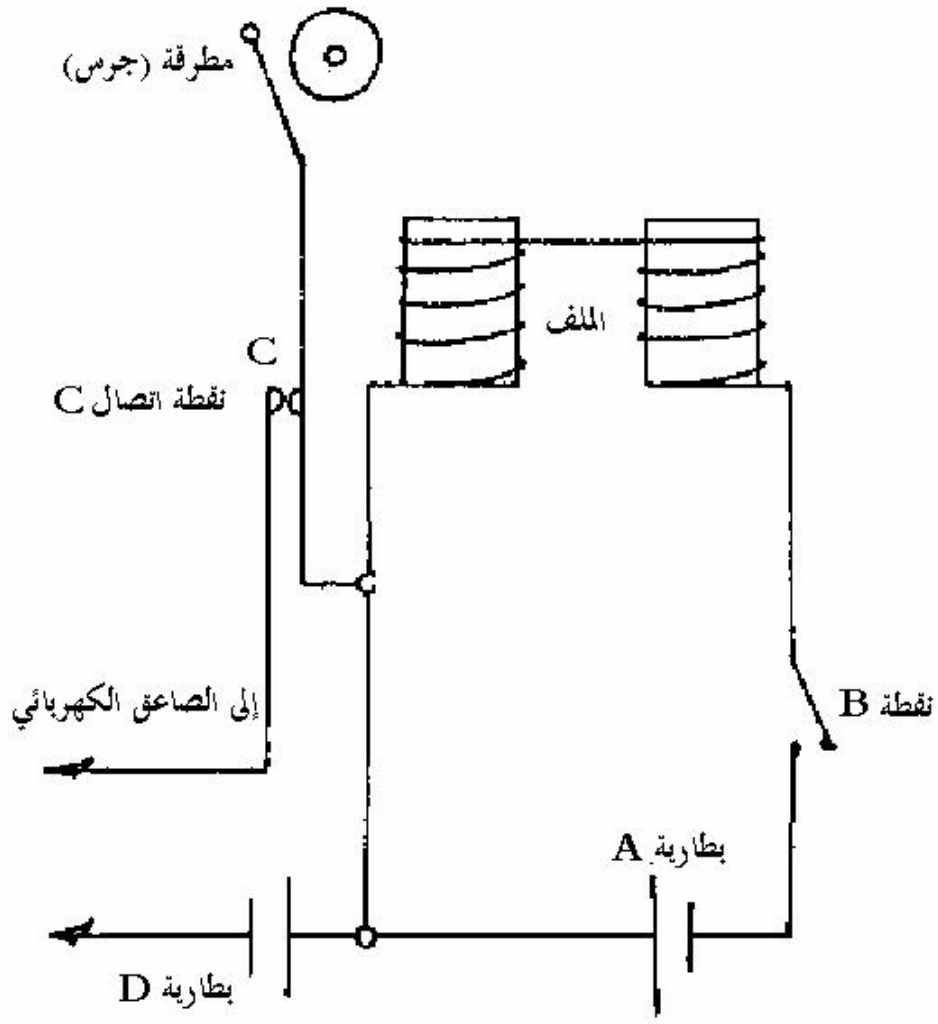

DIODE (

()

:

FORWARD(-) ← (+)
 BACKWARD (-) → (+)

TRANSISTOR (

:

EMITTER ()
 BASE ()
 COLLECTOR ()

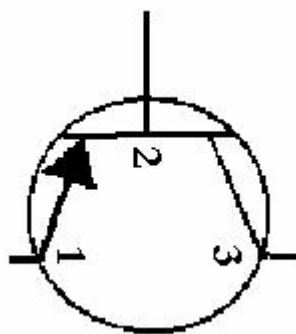

() BASE

C A

.BASE

COLLECTOR

EMITTER

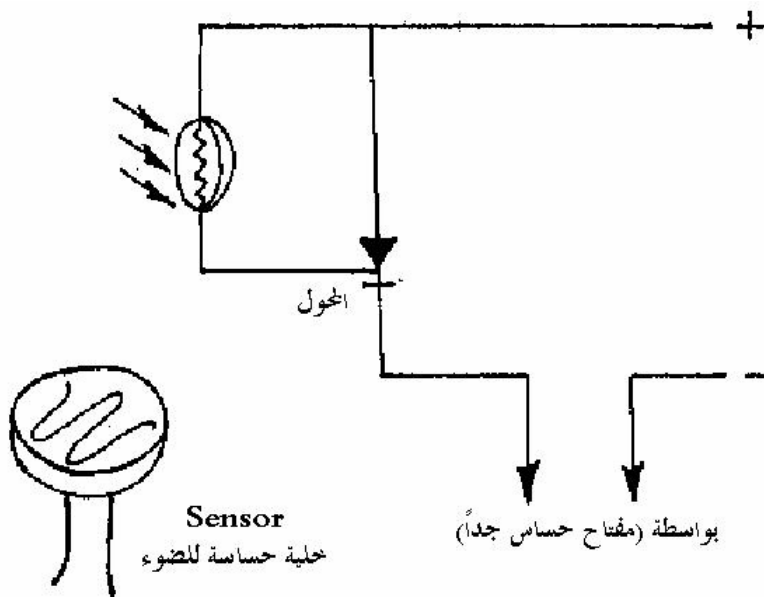
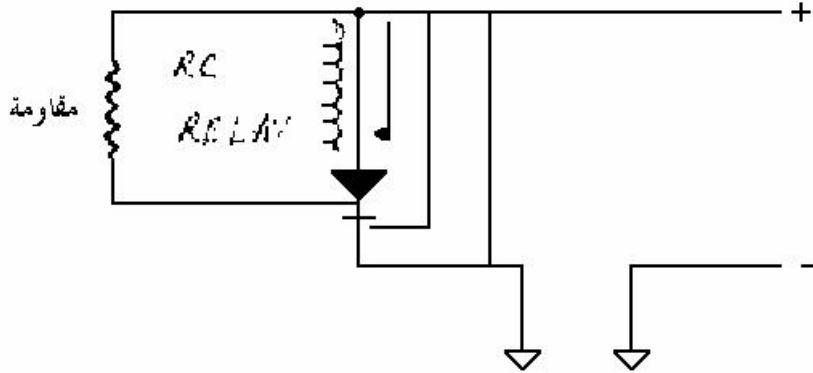

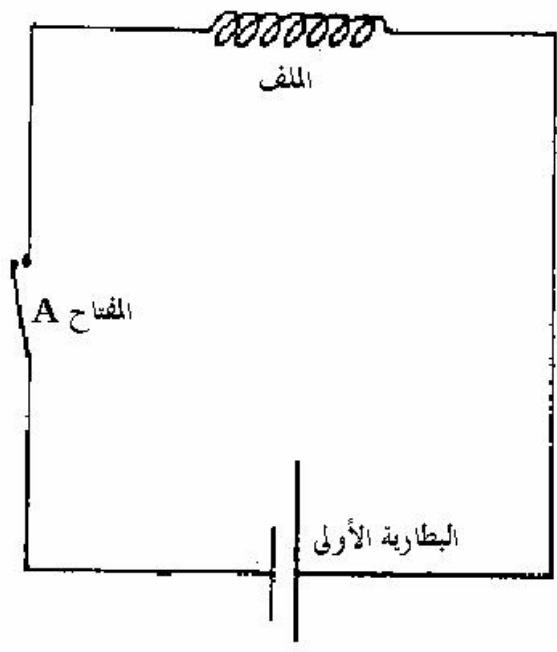
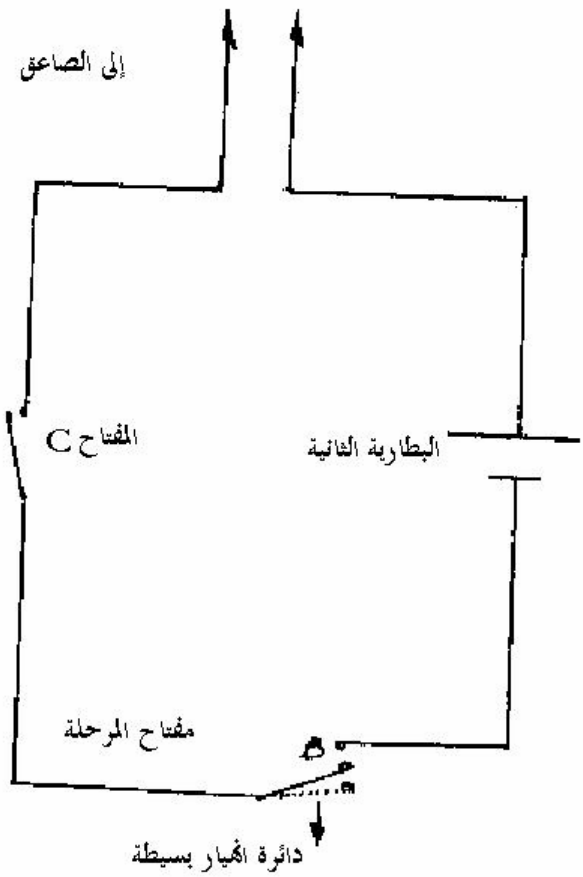

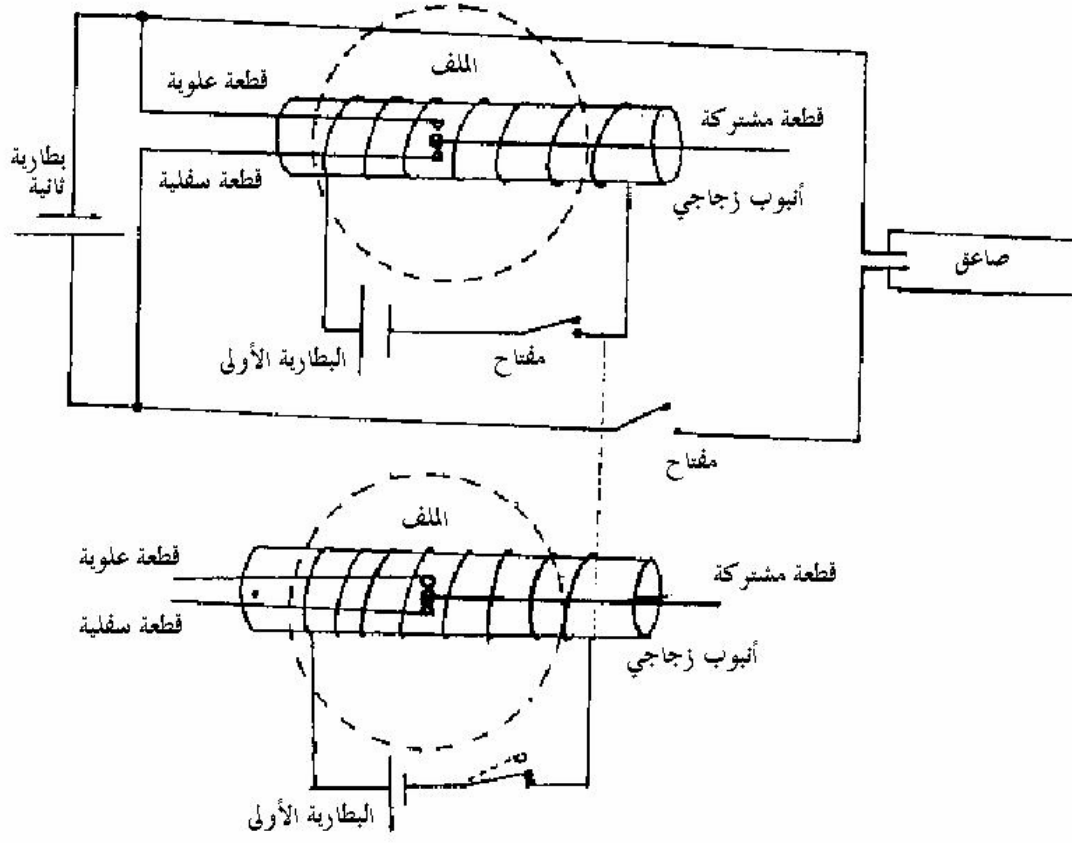

()
()
()

—

.

.

.

.

(

(

(

(

(

(

(

(

(

:

.

.

.

.

()

()

() - -
() ()
() ()

:

▪

▪

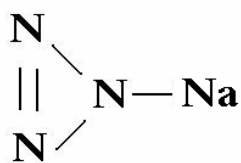
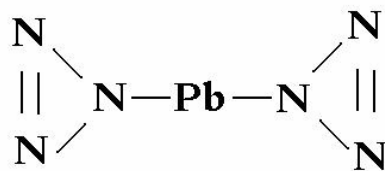

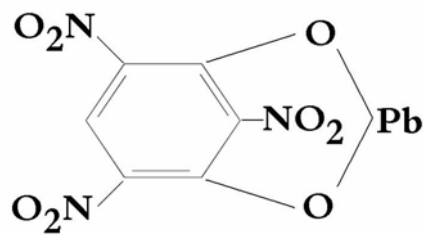
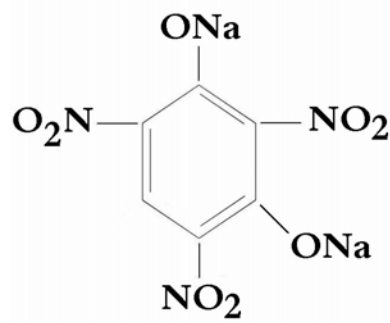
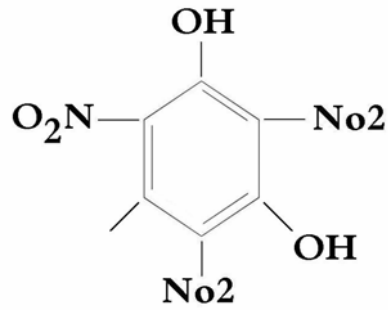

(

%

()

/

/

.Hg (o = nc)2

RDX

() (%) :

%

%

:()

() %

)

(Pyrex

(

%

)

%

.(

%

(

2ON

(

(

()

(



(

%

()

:

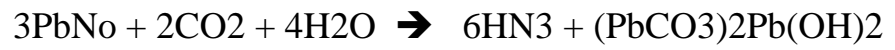

+



.PETN RDX

-
- -
 -
 -
 -
 -
 -

(

(

(

(
) NaNo3
(
)
(

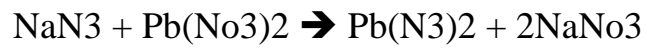

(

▪
▪
▪
▪

▪
▪

(

)

(

(

(

(

(

(

▪
▪

-
-
-
-

(

(

(

(

(

() ()

RDX

%

/

:()

/

-
-
-
-
-
-
-
-
-
-
-
-
-
-
-
-
-
-

(

.

:

% % %

:

(

(

.) ()

()

(

(

(

(

(

(

:

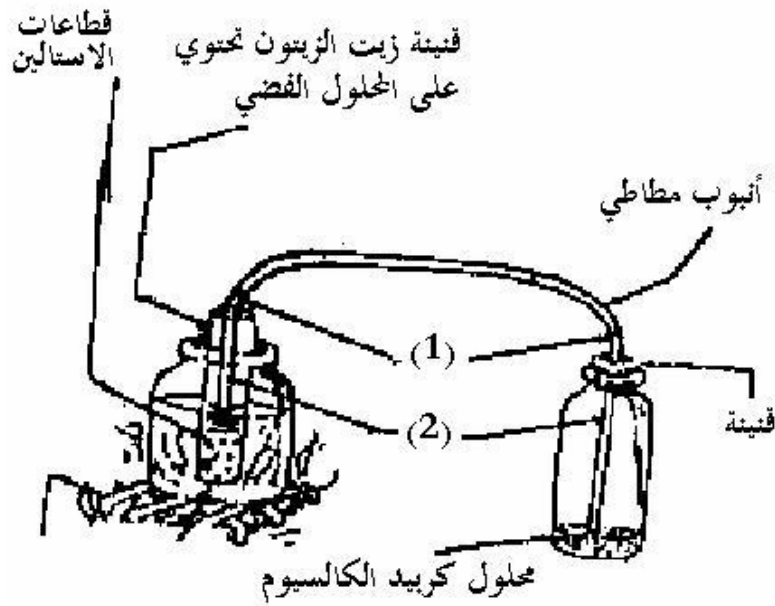
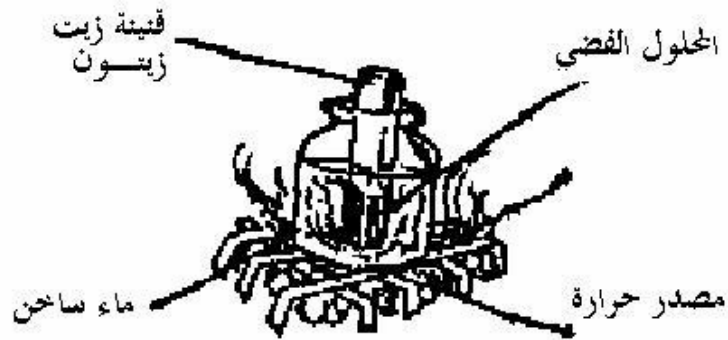

(

RDX

▪

:

▪

:

▪

▪

▪

▪

▪

▪

▪

▪

▪

(

.

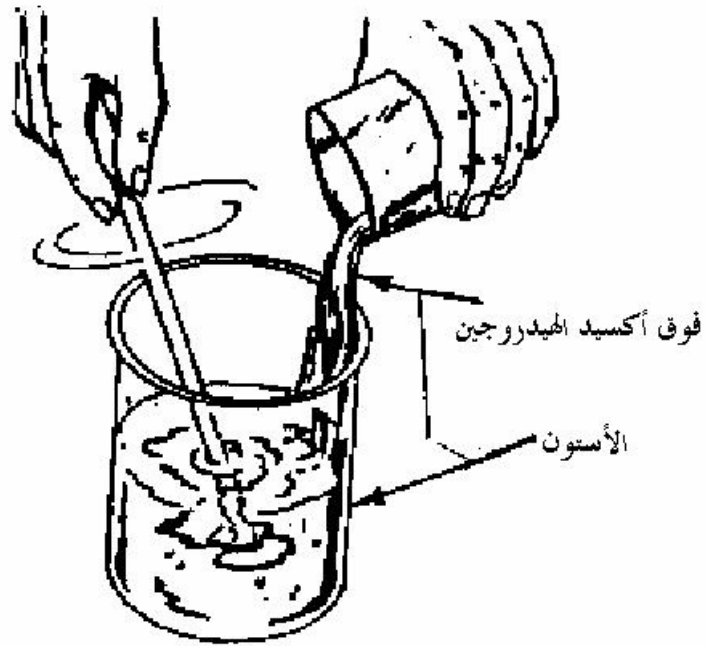

(

:

()

(

(

(

(



بلورات فوق أوكسيد الأستون
تتكون بعد ٢٥ ساعة من التخزين
في صندوق من الثلج الجروش

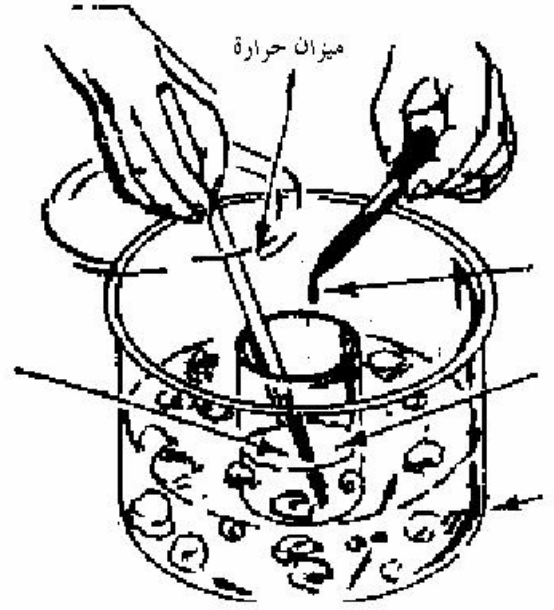

(

(

اغسل البلورات بكميات
قليلة من الماء البارد



محارم ورقية
تستعمل كمصفاة

بلورات فوق أكسيد
الأستون

تخلص (اهمل) السائل
المتجمع بعد التنقية
وذلك برميته

مطاط لتثبيت المحارم
(مُعَيطة)

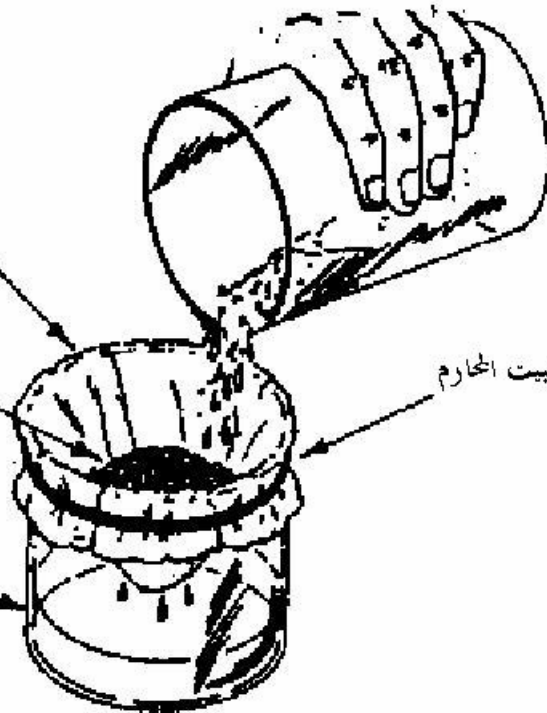



(

RDX



(

()

(

(

:

(

(

(

()

(

(

(D.D.N.P) - - - (

()

.R.D.X

-
-
-
-

()

()

-
-
-
-
-
-
-
-
-
-
-

()

() ()

(

(

()

(,)

(

(+ +)

(

(

()

(

(

()

(

()

(

(,)

(

(,)

(

()

(

:

(

()

(

:

■

(

(

(

(

.RDX

T.N.T

:

RDX

.PENT

H.M.T.D

D.D.N.P

-
-
-
-
-

RDX (

RDX

C3 C4 RDX

RDX T.N.T , / RDX

: RDX

.C4

C4 RDX (

.C4

-

.()

-
-
-
-
-
-
-
-

-
-
-
-

() C4 ()
 () ()
 :
)
 .(C4



C4 ()
 ()

(

()

(

RDX (

()

.(%

.%

(

(

(

.

'

:

(

.

(

RDX

.

(

" "

RDX (

RDX (

) %

(

PH (

)

.(

PH

.

(

) RDX

.(

RDX

RDX

(

RDX

.RDX

(

:

RDX

(

()

(

RDX

.

RDX

(

.

RDX

(

:

(

()

RDX

(

.

RDX

(

.

RDX

:

=

,

RDX

.

(-) (

D.D.N.P

- .()
- .()%
-)
- .(
- .
- .
- ./
- .()
- .
- .
- .
- .
- .
- .
- .
- .
- .

▪
▪
▪

_____ () (

() (

(

(

(

(

() (

(

() (

(

(

(

(

(T.A.C.C)

(

(RDX)

%

-

-

-

▪

▪

▪

▪

▪

▪

▪

▪

- .
- .
- .
- .
- .()
- .
- .

(,)

(

)

()

(

(

:

.()

:

(

.()

()

(

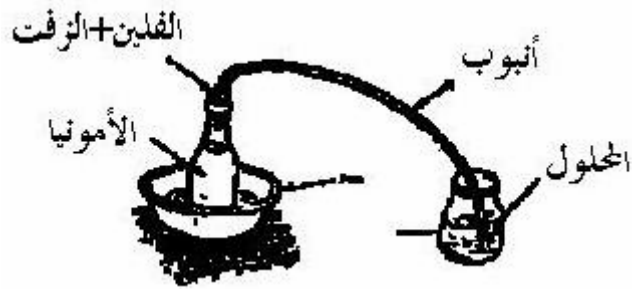

(

- ()

()

(

:

(

:

(

:

(H.M.T.D) (

H.M.T.D

()

.RDX

() () ()

()

- ()

.

-
-
-
-
-
-
-
-
-

()

(

(

(

()

(

(

:

(

(

(

:

(

(

(PETN)

(

Pentacrythrite Tetra Nitrate

PETN

Pentacrythrite

Pentacrythrite

(

(

(

:

(

(

(

(

)

:

(

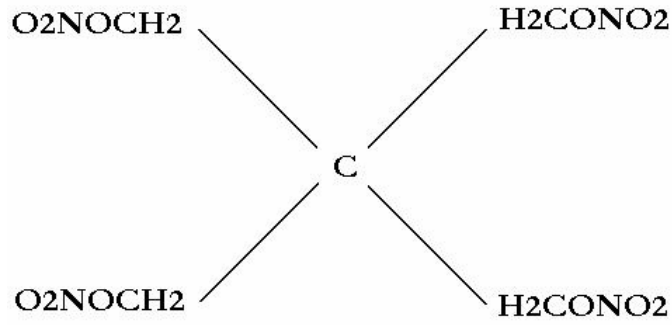

PETAN

% , = (

PETN

:

⋮

Pentacrythrite

▪

.PETAN

▪

⋮

▪

▪

▪

×

▪

▪

▪

▪

▪

▪

▪

▪

()

▪

()

▪

()

▪

▪

▪

▪

_____ :
:

()

(

.

.

(

(

) .

.(

(

.

.

(

(

.

(

.

Pentacrythrite

(

.

:

(

(

Pentacrythrite

Pentacrythrite

(

:

(

(

)

(

.(

(

(

(

(

(

(

(

(

(

(

(

)

.(

- - (

(

:

(

(

(

(

(

(

(

(

(

(

()

(

%

(

(

(T.N.T) (

T.N.T .

$C_6H_2CH_3(NO_2)_3$

T.N.T

()

T.N.T

/

T.N.T

:

NO₂

.M.N.T

:

▪

.D.N.T

:

▪

T.N.T

:

▪

T.N.T

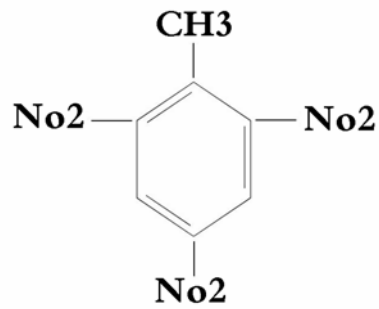
T.N.T

:

) %

(- -

%

▪

▪
▪

(

(

(% %)
(% %)

+

(

(

.()

(

(

.()

(

(

:

(

(,)

(

()

(

:

(

()

(

:

()

% + % :

C3

T.N.T

(

(

(

:

(- ,)

(- ,)

T.N.T

T.N.T

(

(

(

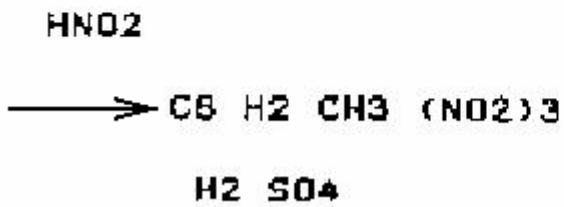
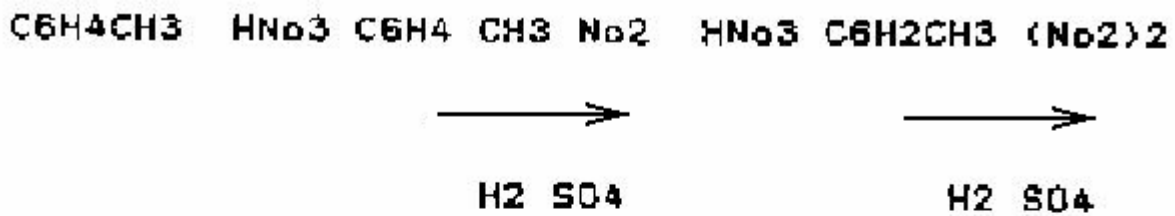

:

T.N.T (

T.N.T (

T.N.T

T.N.T (

T.N.T

T.N.T

T.N.T

-

-

(

(-)

:

-
-

(

% %

% %

-
-
-

(

(

(

:

)

(

(

(

(

() (

▪

▪

(

(

(

(

(

(

(

(

+

:

:

+ % + % + % + % (

.%

.% + % + % (

. % + % + % (

+ % , + % , :

.% + % + % ()

+ % + % :

.% + % + % ()

+ % + % , + % :

.% , % ,

(

:

.%

+ %

+ %

(

+ %

+ %

+ %

(

.%

+

()

()

.

.

.

.

.

)

(

.

(

T.N.T

:

-
-
-

(

(

(

(

(+)

)

(

(
(

%

(

(

(

:

(

()

()

)

(

)

.(

()

.

.

.

) () ()
 () ()
 ()
 . ()
) ()
) T.N.T (/) T.N.T %
 . (/) (, ,) T.N.T %
 . (PLX) %
 (AEREX)
 () % %
 (/)
) .
 (

:
 :
 :
 :
 :
 :
 :
 :
 :

)
 ()
 ()
 ()
 ()
 ()
 :

_____ :

()

_____ :

(

:

(

:

()

H.T.H () (

(H.T.H)

.() H.T.H %

.()

.()

(

(

(

(

:

$$\frac{(\quad)}{(\quad)}$$

+

.T.N.T

%

)

.(, =

)

() (

)

(

.(-)

▪

▪

▪

▪

▪

▪

▪

()

(

(

(

(

(

+

:

:

▪

▪

▪

▪

- .
- .
- .
- .
- .
- .

()

()

(

(

:

()

(

:

(

(

:

(

.%

()

-
-
-
-
-
-
-
-
-

▪
▪ ()

()
(/)

(
(/)
(
(
(
(

:

(
(

:

(

(

(

.(-)

.()

-
-
-
-
-
-
-

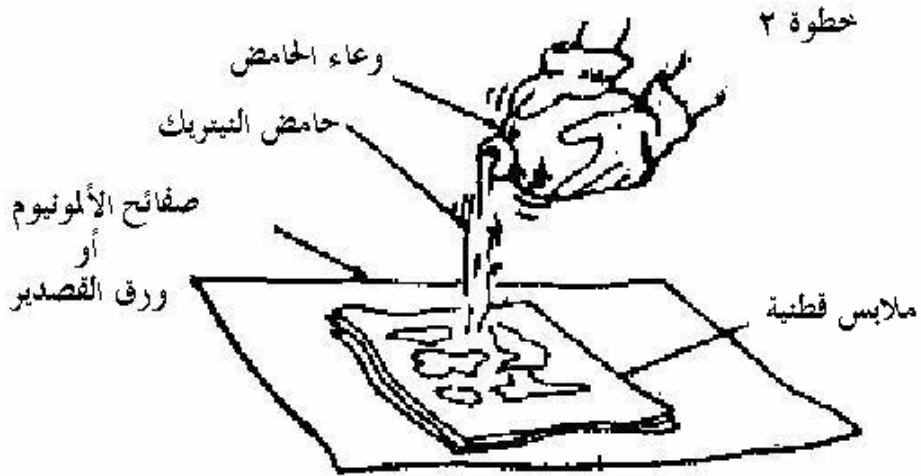

G A

+
 ()
 (G)
 (A-1-5) G ()
 :
 : G ■
 " " + " " (■
 : A-1-5 ■
 () % (■
 () % (■
 " " % (■

(NH2)

:

() ▪

▪

▪

.()

▪

▪

▪

▪

▪

(A.1) T.N.T %
5-)
, .C4 (1-A

A1

(G)

PBXN-1

.T.N.T

(/)

(/)

G

A.1

G

:

:

G

RDX

(

RDX

-
-
-
-

RDX

(

RDX

:

.RDX

%

RDX

%

(

(

.()

T.N.T

(

(

C4

:

.() ()

+ + +

:

()

RDX

:

.() - -

(/)

.()

-
-
-
-
-
-
-
-

(

- () .

. ()

. + + .

() ()

(

(

% (

(

(

%

▪

▪

.

.

.

" "

.

() ()

()

-

-

()

.

.

()

()

()

.

()

()

.

()

.

-

.

()

.

()

()

(... ..)

.

()

:

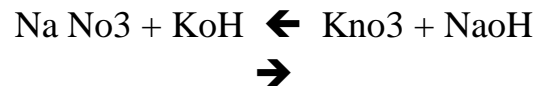

...

:

▪

▪

▪

:

-

(

(

(

.

-

-

.()

()

" "

.

:

%

% ,

% ,

-
-
-

.

:

%

%

%

-
-
-

:

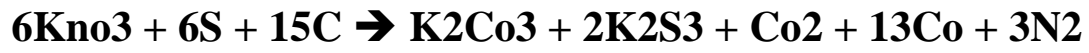

:

:

.% + % + % (

.% , + % , + % (

% ، + % ، + % (

% ، + % ، + % (

(+) :

() ()

:

+ + ، + ، +
 .(+) +

:

.

:

(

(

(

.)

(

.)

:

()

(

(

(

(

حبيبات البارود الأسود

قطعة القماش المصقفي



()

-
-
-
-
-
-

()

+ +

(
(
(

:

(

(

()

(

(

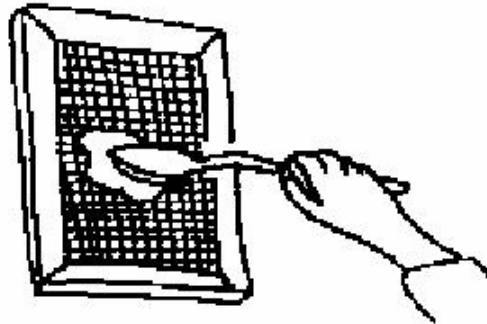

()

▪
▪
▪

+

)%

()

(

%

%

(

)

.(

(% %)

(

(

%

(

.()

.()

.()

:

:

()

(/)

/

:

T.N.T

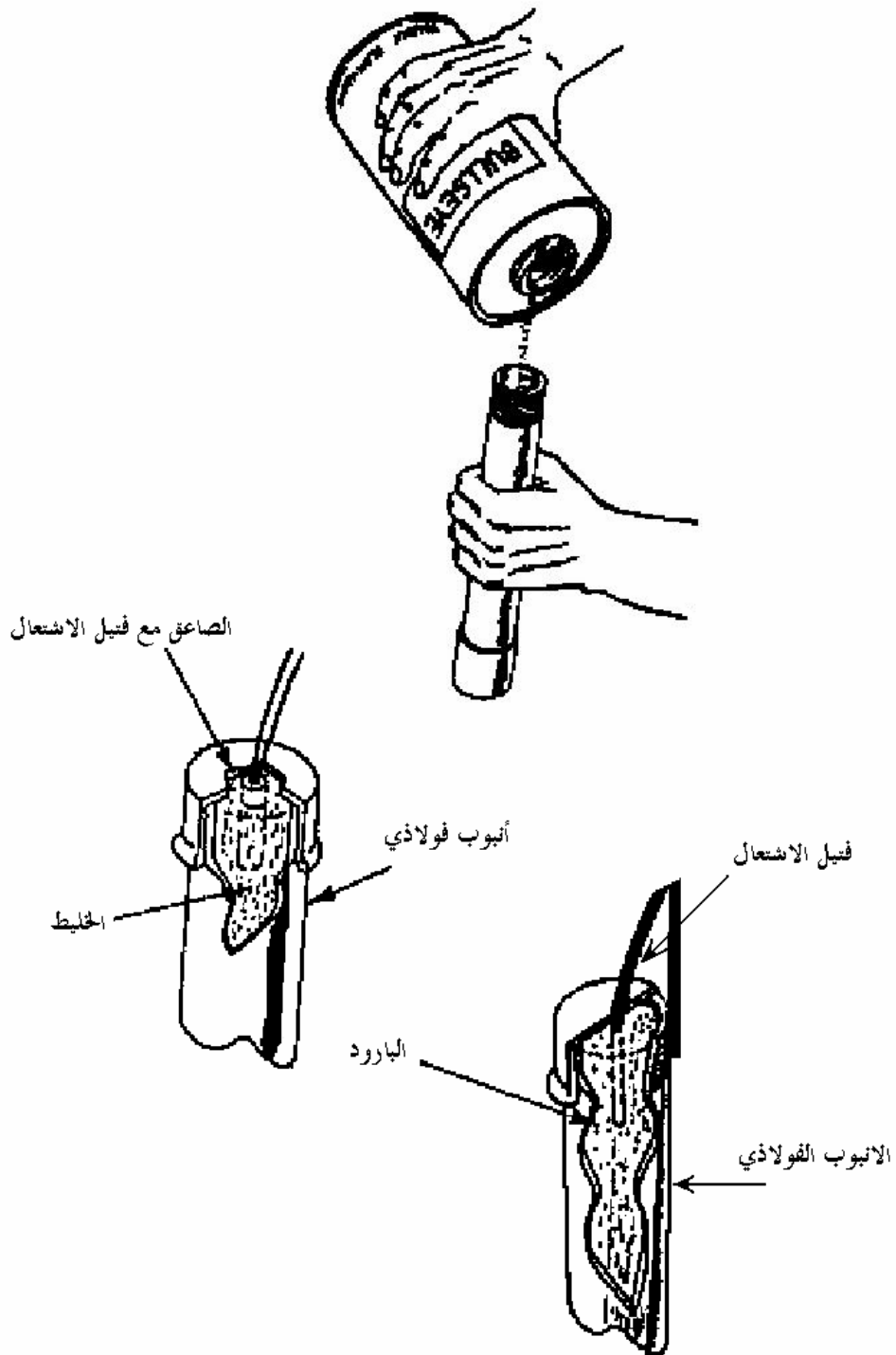

()

(,) , ()

.C4

.()

.() ()

.()

.()

(,)

(

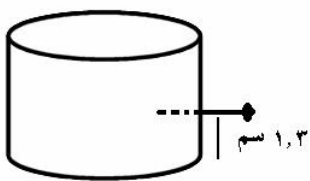

() / (

(
(
(

+ + (,) (

() .() () (

(
(
(× ×) (

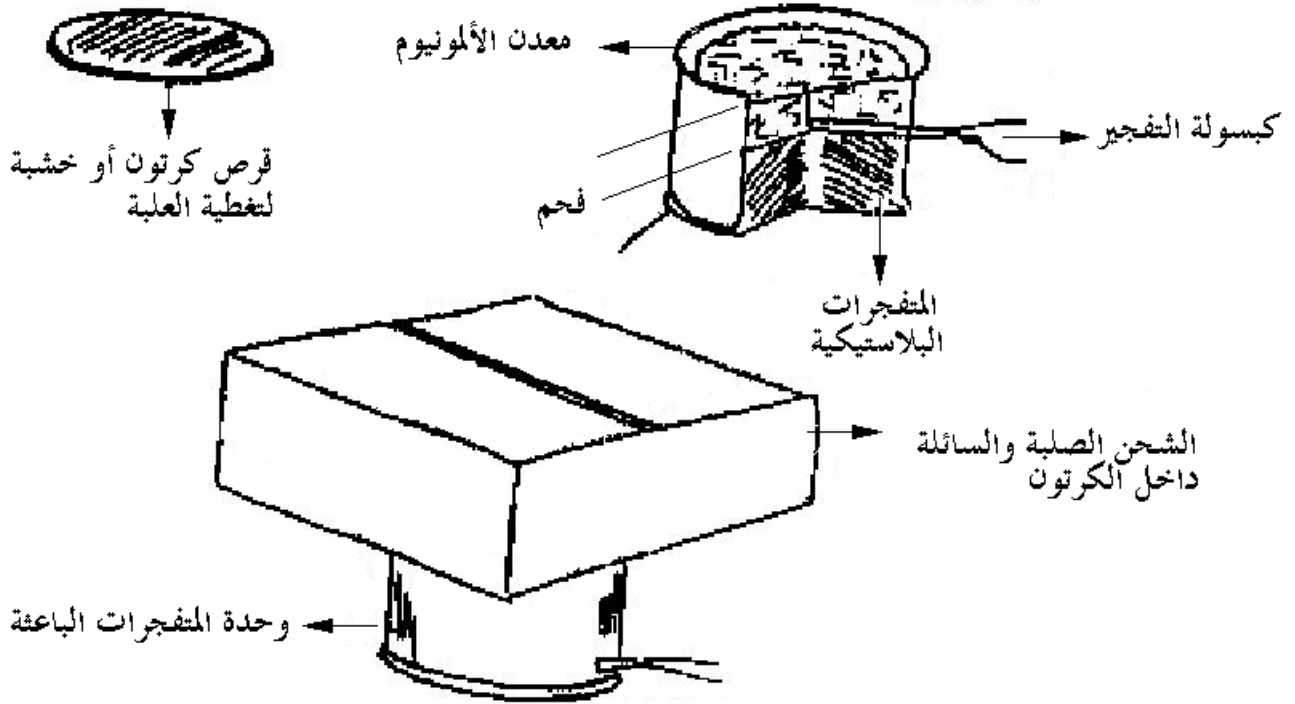

NO₃

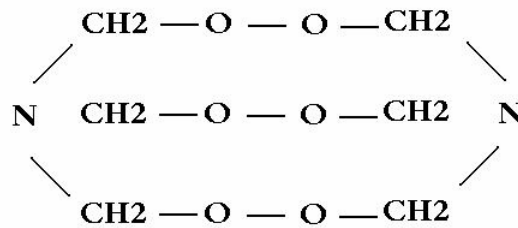

()

.

.

-

-

.

.

:

:

(

:

(

:

(

()

.

()

.....

()

NH₄ClO₄

.KClO₄

KClO₃

KNO₃

) ,

.(

"

"

.()

()

"

"

.

.

-

-

-

- . . .

.

.

.

▪

.%

▪

.

▪

.

▪

.

.%

:

T.N.T % + % :

T.N.T T.N.T (

)

T.N.T (

T.N.T

.

T.N.T

(

(

:

T.N.T % + % (

T.N.T % + % (

.T.N.T % + % + % (

T.N.T

T.N.T

% + % + % :

% + % :

:

:

% +

%

▪

% , +

% +

,

▪

.()

% + T.N.T % +

% :

T.N.T

+ % , +

, +

% :

.()

%

+ % , +

%

()

% ,

+

:

.() + :

. % + % + % :

+ () % + % + % :
%

. + :

. .

:

+

=

+

$$= (\% - \%) + (\% - \%)$$

. % +

% (

(

(

. % + % (

-

+ % + % (

()

, % + % , + % , (, + +

T.N.T

%

%

.%

:

(

(

:

:

:

. + + + (

.

% + % + % + () % (

.

.

.

. + % (

.

:

(

(

.

:

() (

()

+ + (

:

% + % + % + % (

$$\begin{array}{cccccccc} . & + & & + & & + & & \\ & & & & . & & & \\ & + & & + & & + & & (\\ & & & & & . & + & \\ & & & & . & & & \\ & & & & & & & : \\ & . & + & & + & & & \hline & & & & & & & \\ & & & & . & & & \\ & & & & & & + & : \\ & & & & & & \hline & & & & . & & & \end{array}$$

:

· + (

+ () (

·

·

:

()

.

%

.

:

:

()

(

.

(

.

()

(

.

(

.

-

,

.

(

(/)

()

(

.

(

.

(

() (

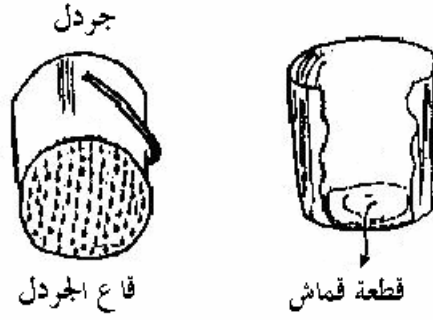

(

(

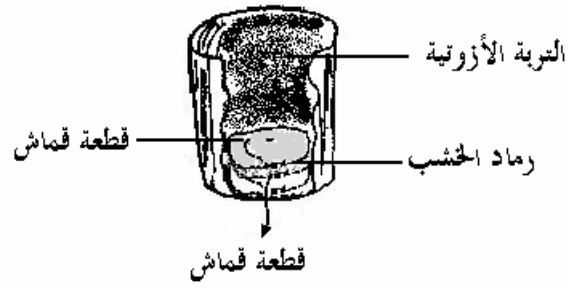

()

(

(

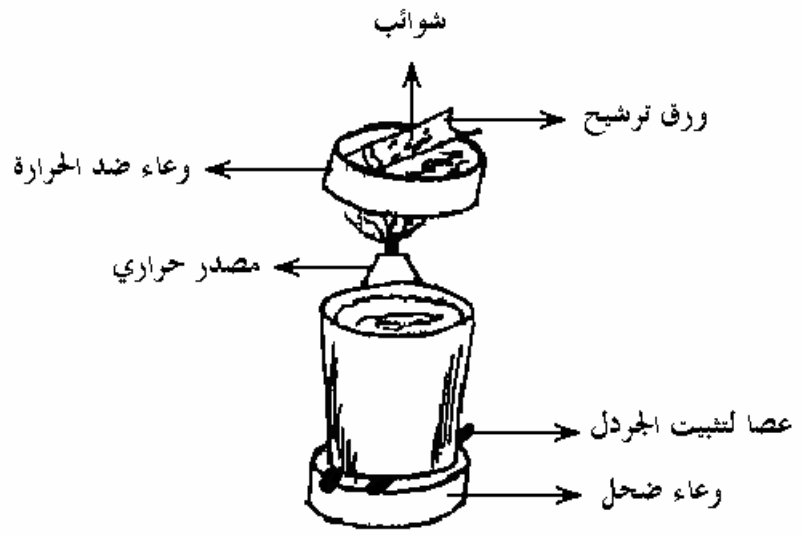

(

(

(

(

(

.(

)

(

)

(

(

.(

:

()

.()

.()

.()

:

=

(

:

(

(

(

:

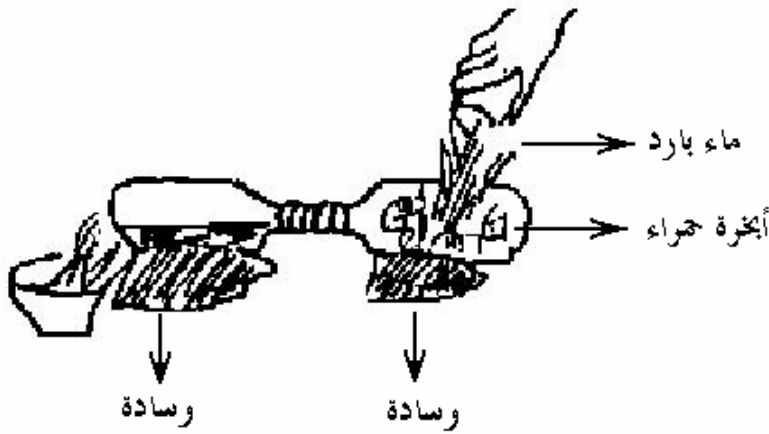
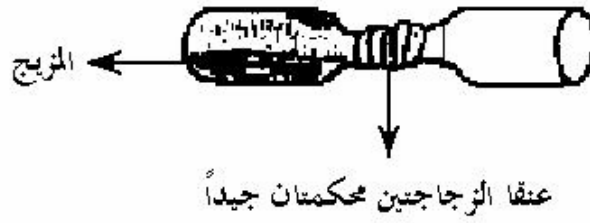
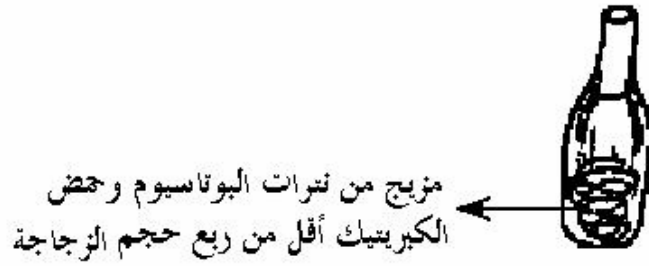

)

.(- - -

:

▪

()

:

T.A.C.C

▪

▪

%

▪

▪

()

▪

▪

()

▪

▪

+

▪

+

▪

▪

▪

()

()

(

(

()

(

:

(

(

()

(

(

(

:

:

:

() (,)

▪

▪

▪

▪

▪

▪

▪

▪

▪

▪

▪

▪

▪

▪

▪

() (:) (/ :)

+

+

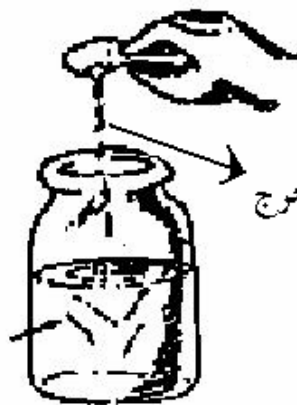
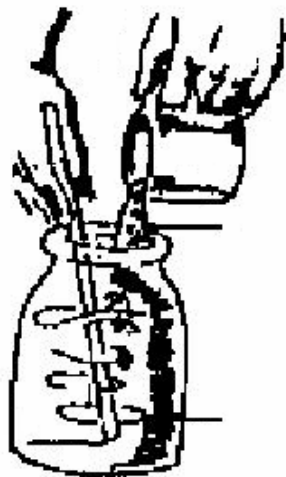

الحامض المستخرج
من البطارية



(, + / ×)

(
(

(
(
(

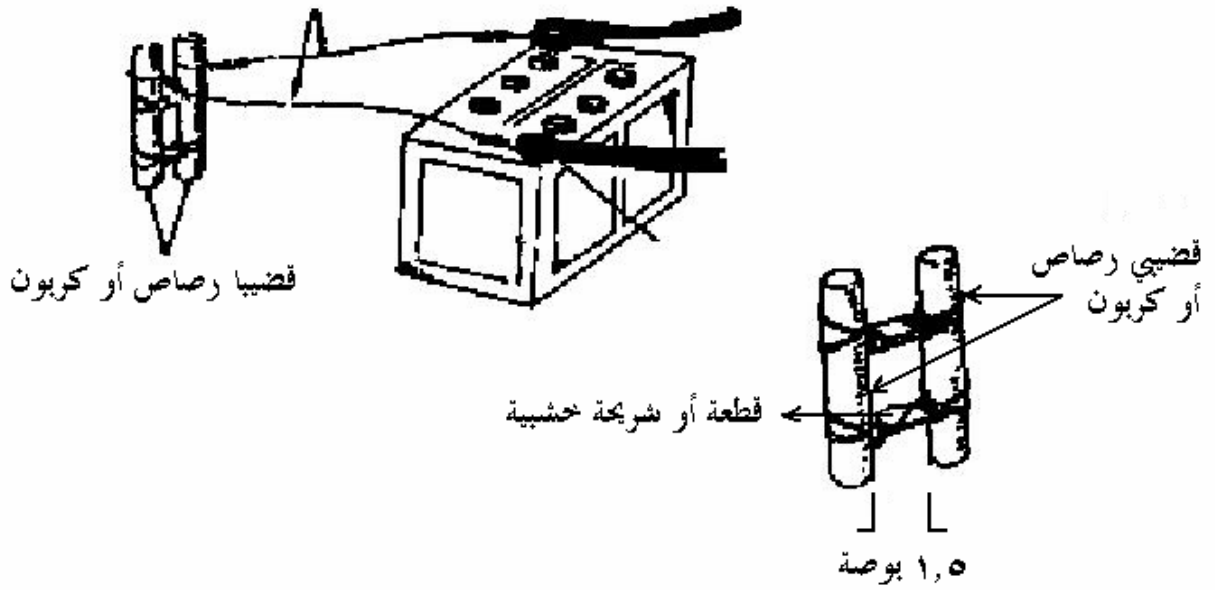

(

(

(

(

)

(

:

(

(

(

%

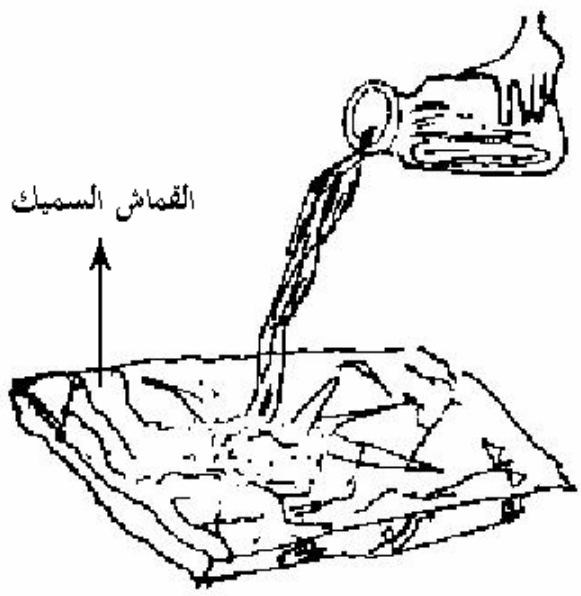

(NaNO₂)

(KNO₂)

-
-

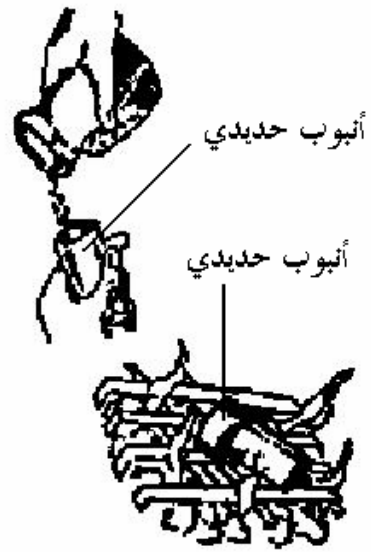

(

()

(

()

(

(

(

()

(

(

.NaNO KNO2

:

:

.() % + % ▪
 .% + % ▪
 . % + % ▪
 . % + T.N.T ▪
 . % + % ▪

■ % + %

(:

(:

(H2SO4)

(

(

(

:

:

:

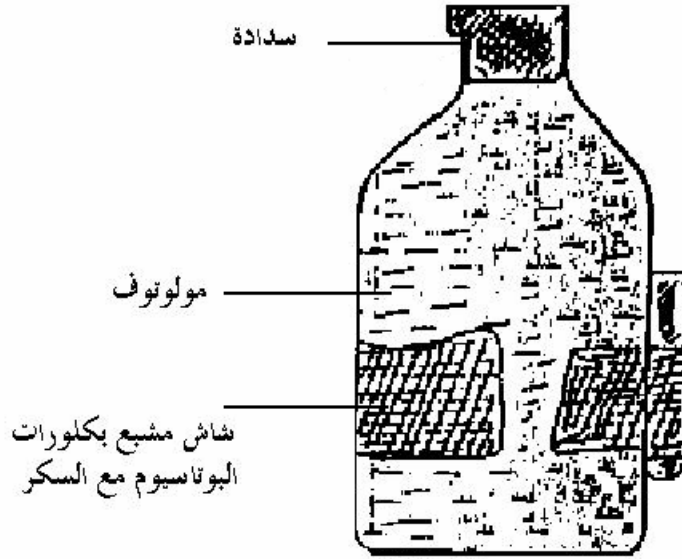

.
 .
 ()
 .
 . .
 .
 :
 + () +
 .
 :
 . % + () % + % ▪
 :
 . () % + % ▪
 .
 %
 %
 % + %

.

:

.

:

.

.

:

.

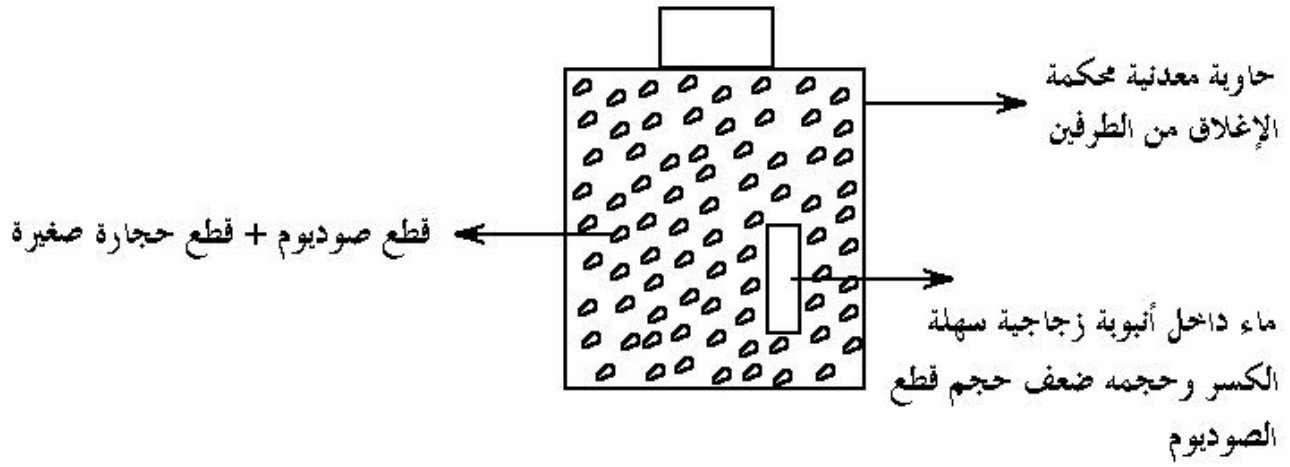

:

-
-
-

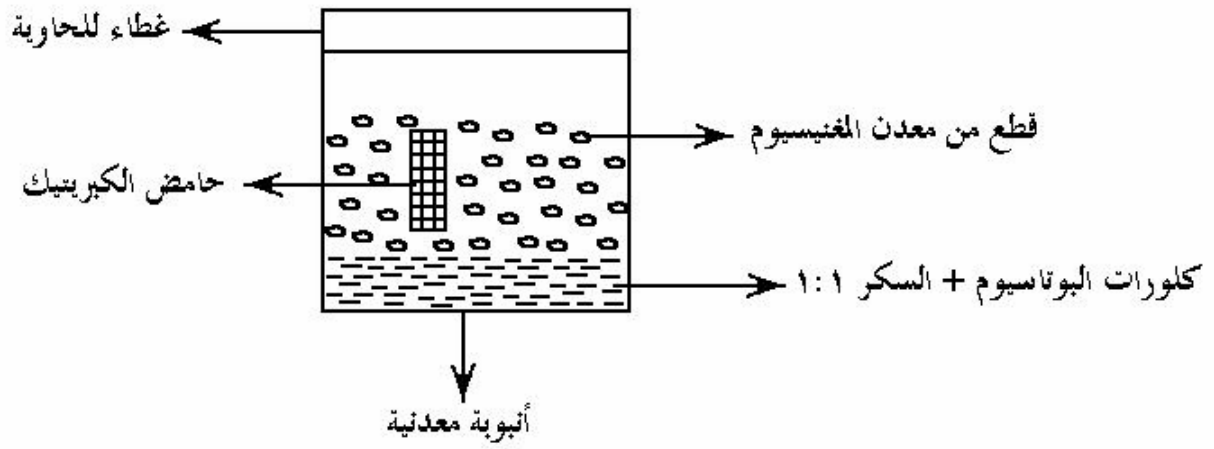

:

-
-

(

(

()

:

(

(

:

:

RDX

▪
▪

RDX

()

:

▪

▪

:



:

.



:

()
)

()

(

(

RDX

·
:

+

(

.()

(

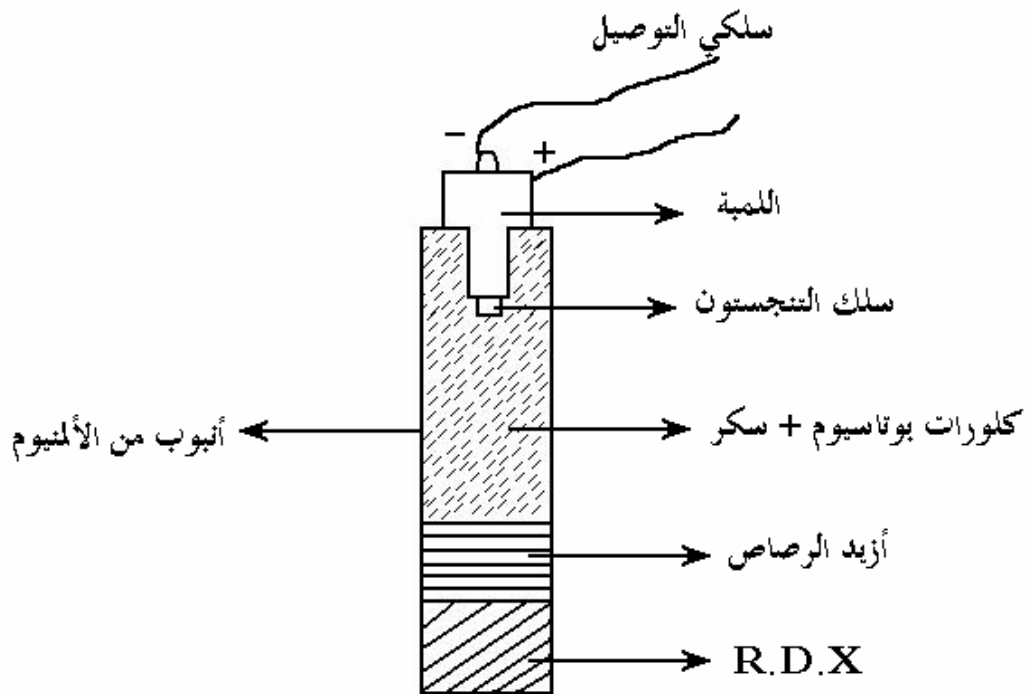

:

-
-
-
-
-
-

-
-
-

(

(

(

(

:

+

:

()

(

: + (

(

(

:

:

_____ (

+ + + + +
+ () +

_____ (

+ + + +

(

+

+

(

+

+

(

+

:

▪

▪

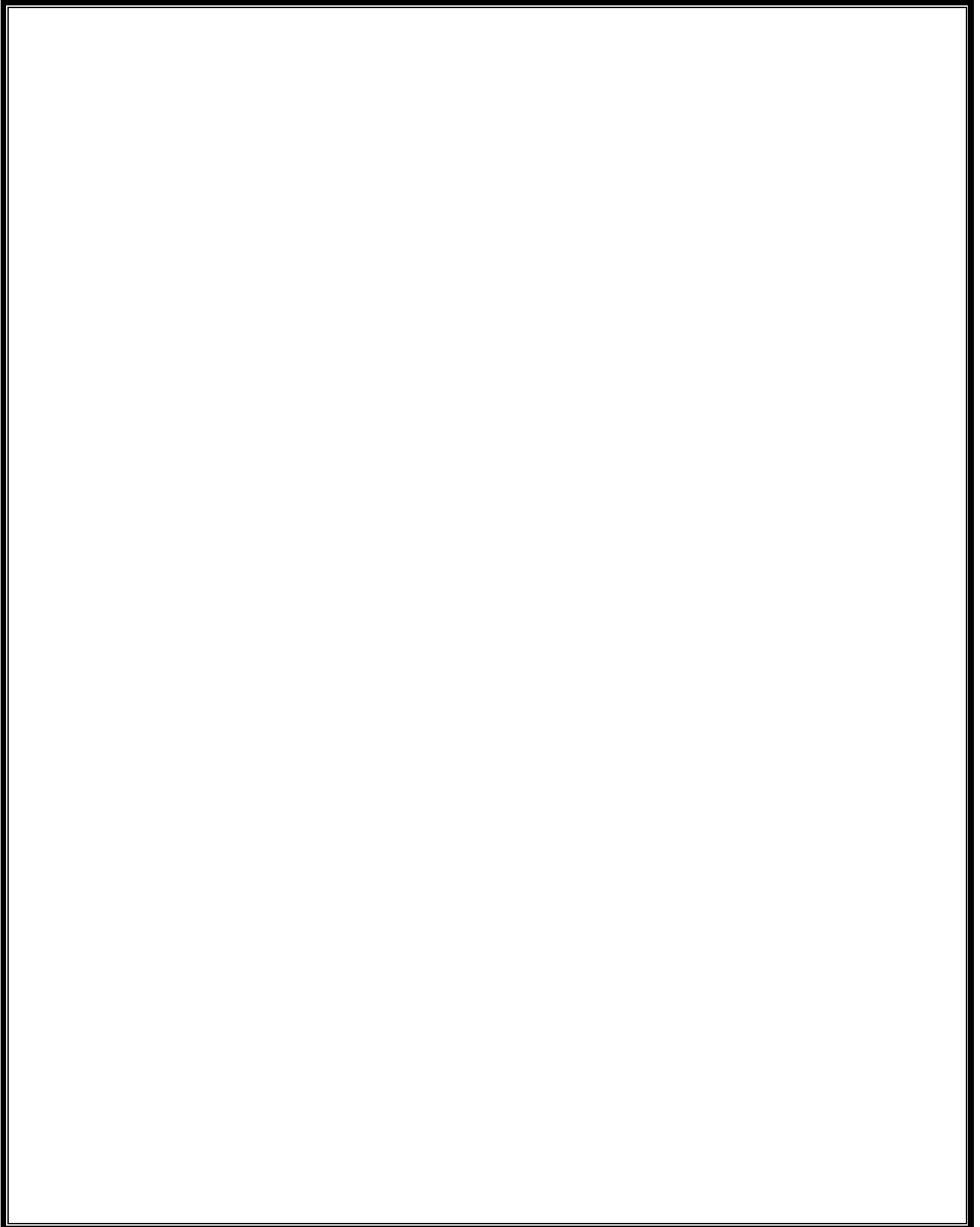

:

.....

.

(

.

(

.()

(

.

(

- -

.

-
- : () .
 - : () .

-
-
- : × , .
 - : , .
 - : .
 - : .
 - : / .
 - : .
 - : .
 - : () .



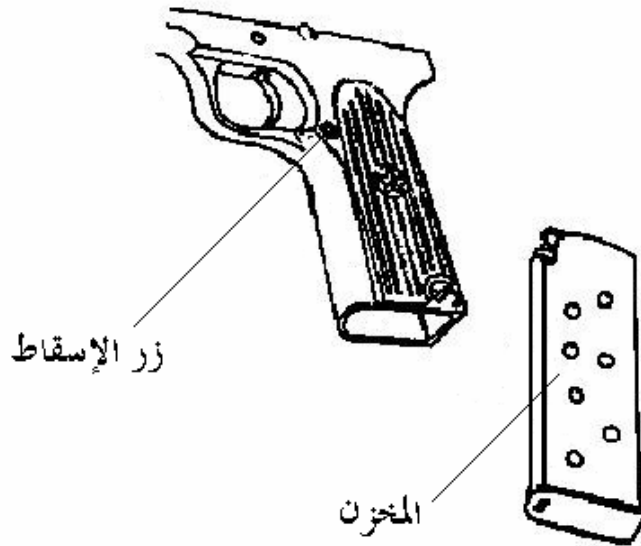
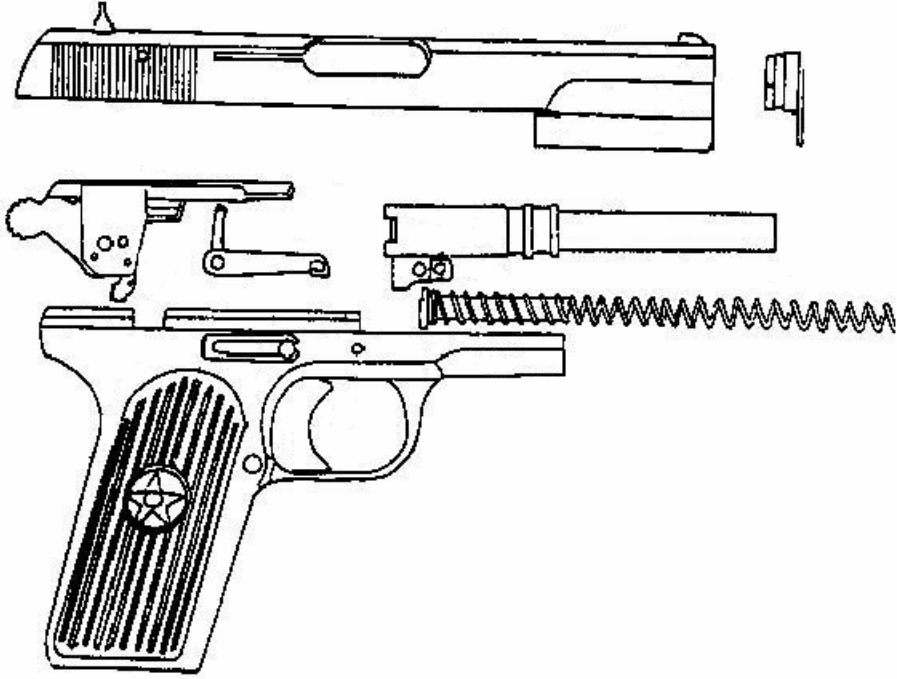

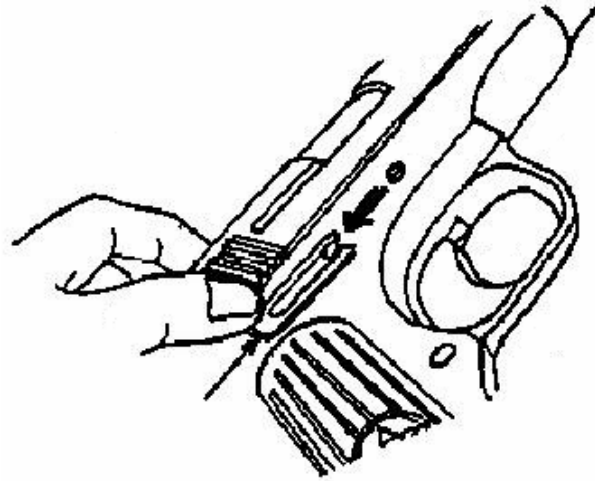

(

(

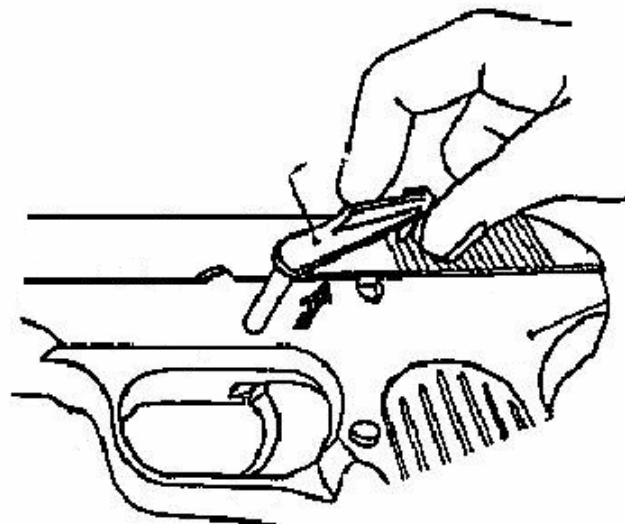

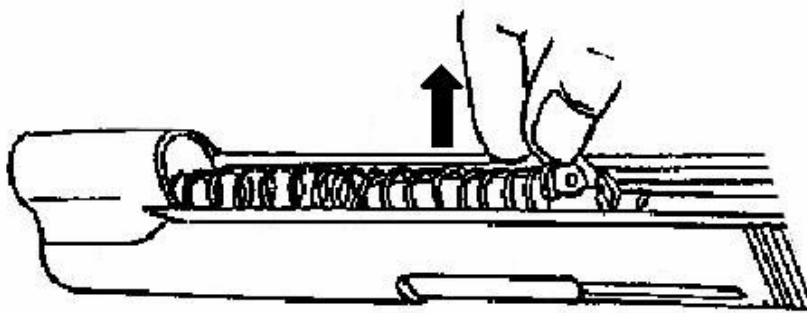
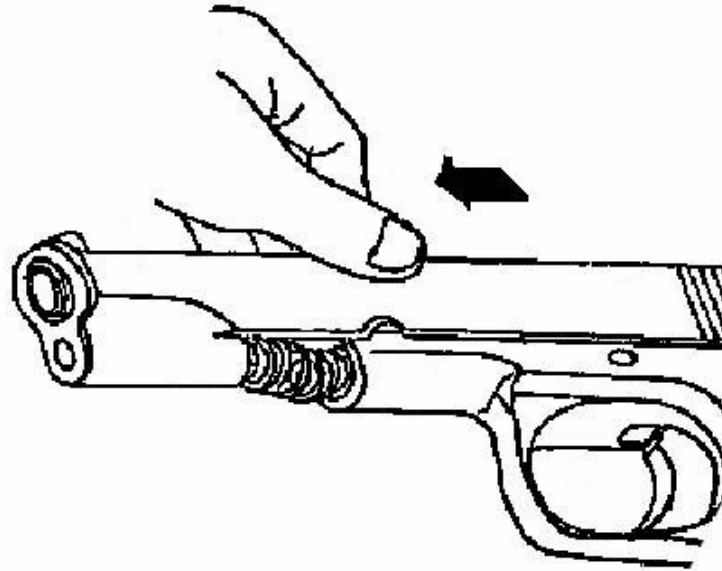

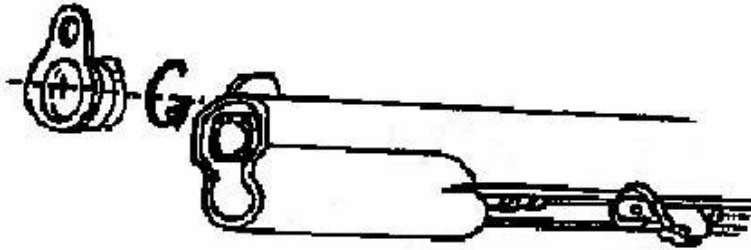

(



(

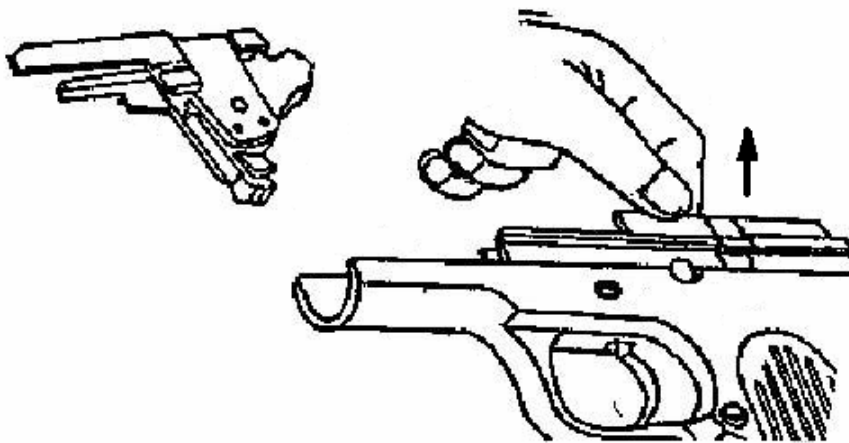

(

- × :
- / :
- () :

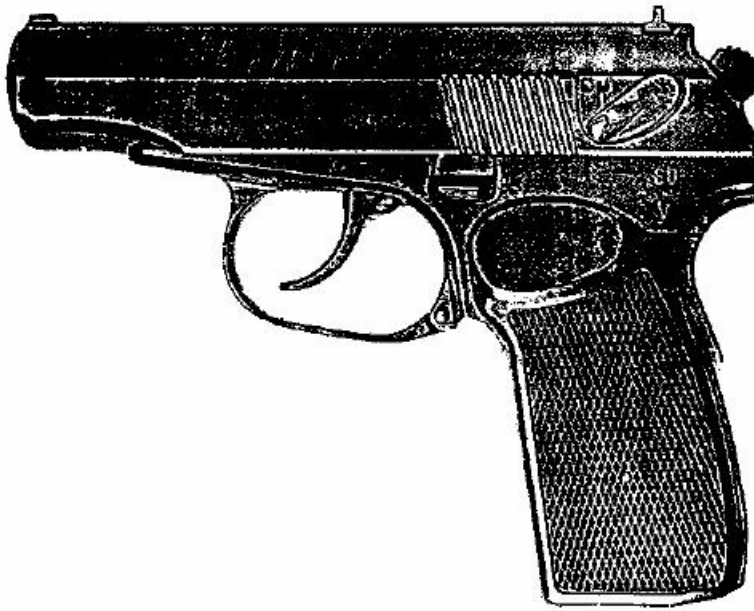

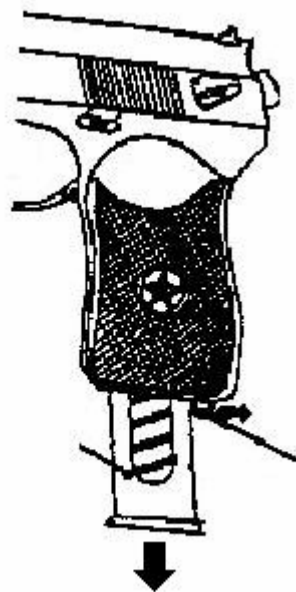
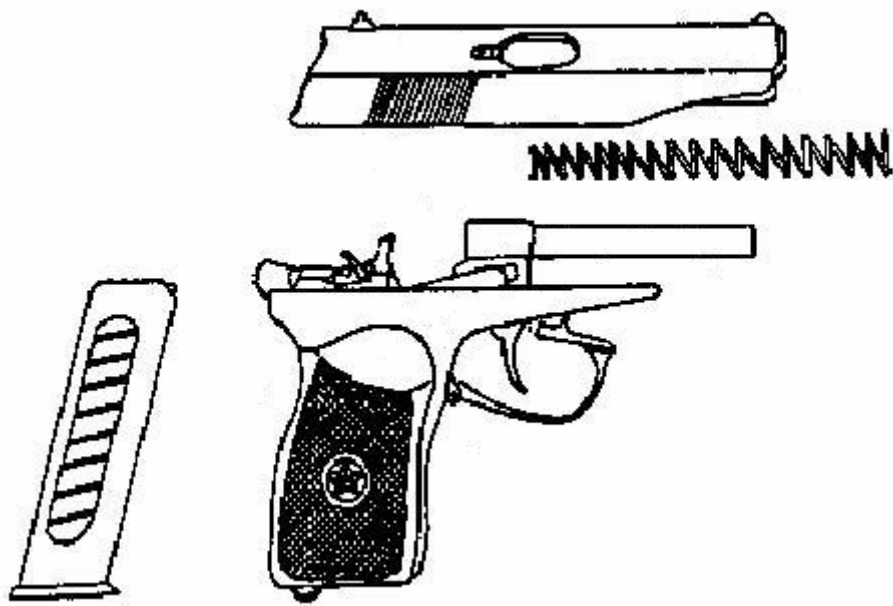

(

(

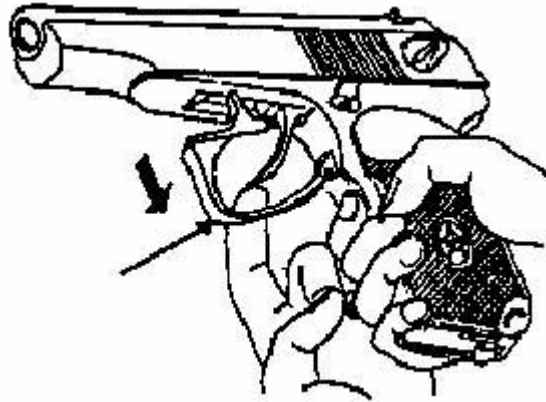

(

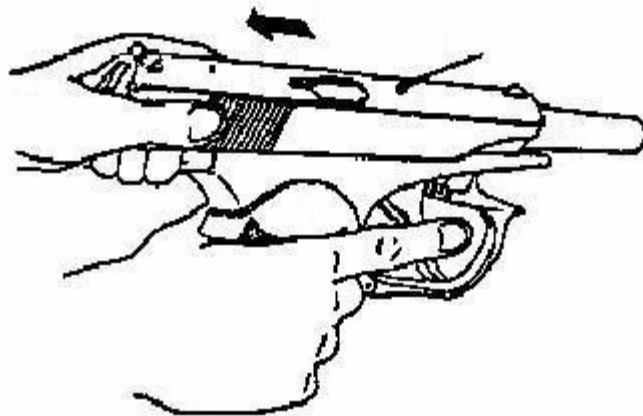

(

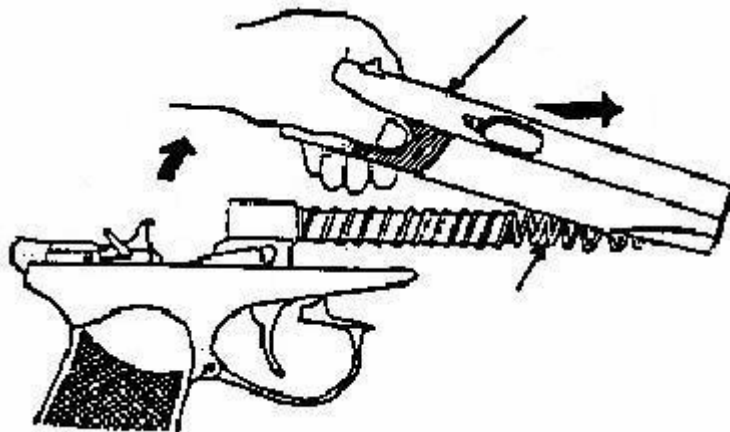

(

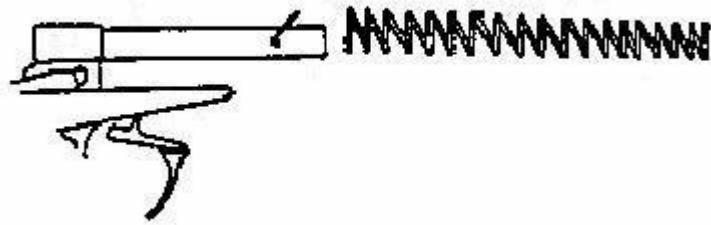

.()

()

() (

.()

- : ■
- : ■

()

·

- :

() (

() :

-
-

·

:

() :

·

- - :

:

- .
- .() :
- .() :

()

()

(

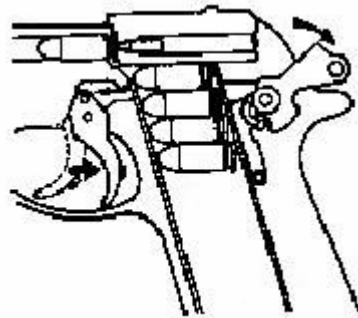

(

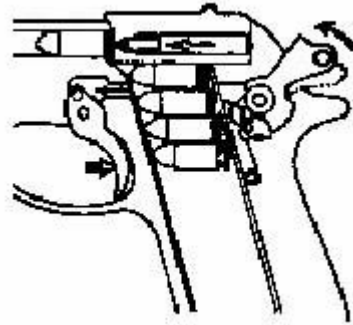

(

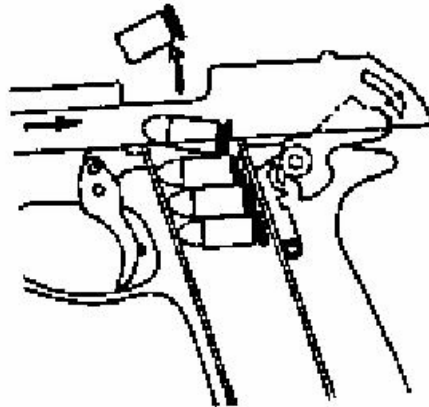

(

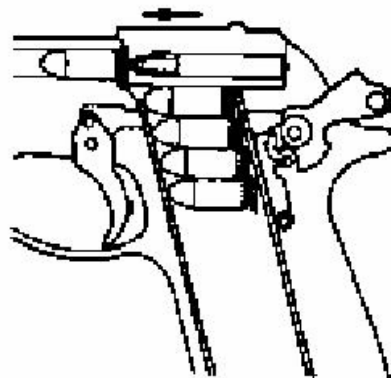

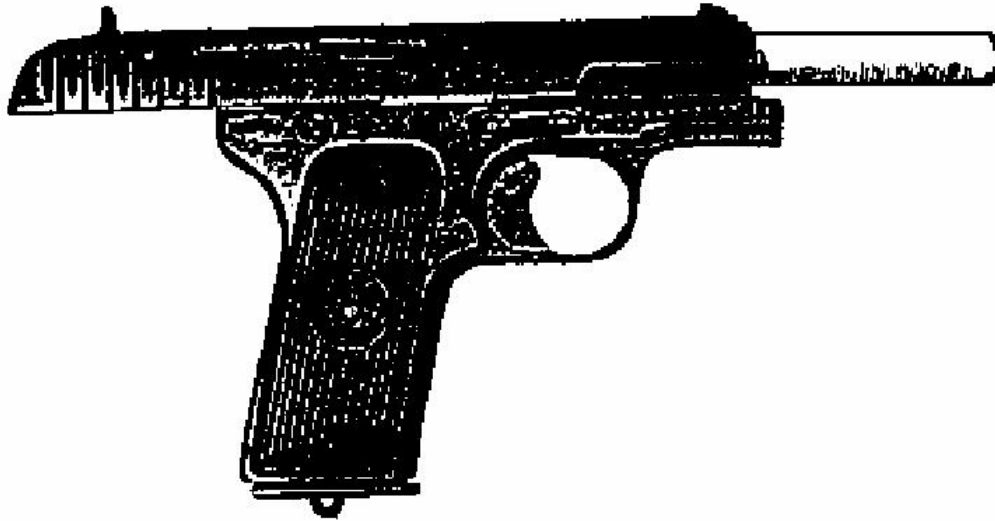

(



(



(
()

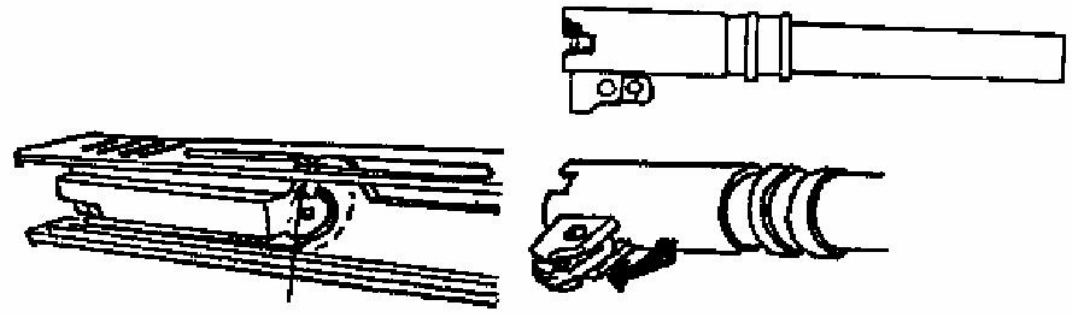

(
(

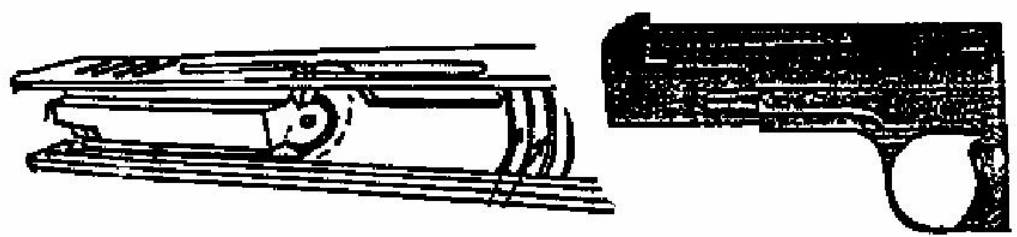

(

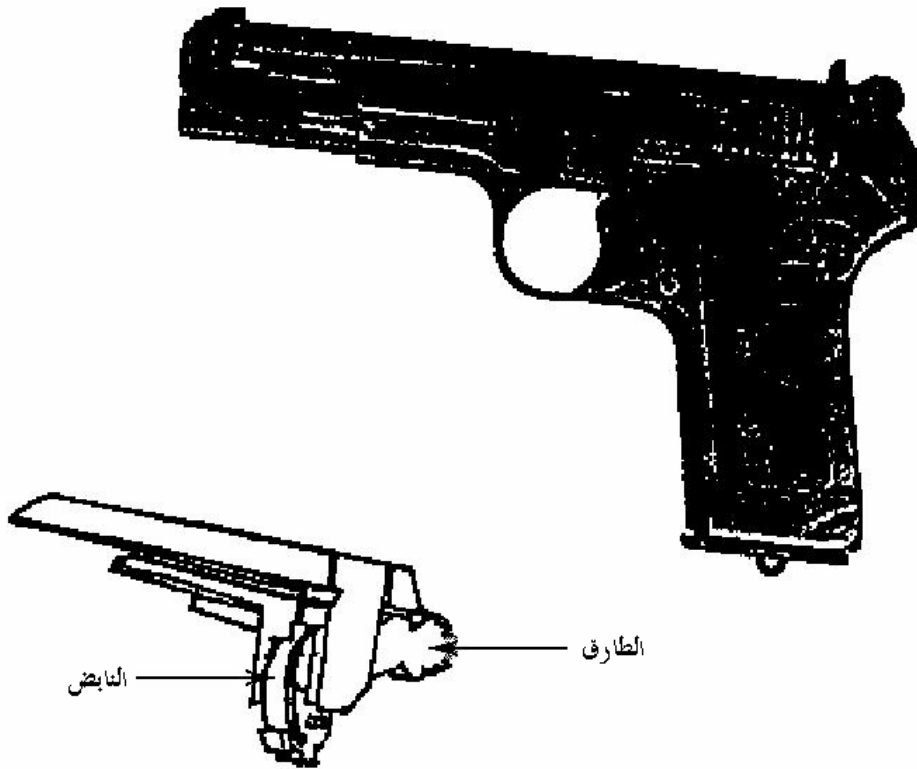

(

()

(

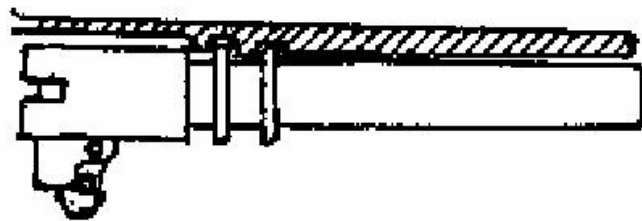

(

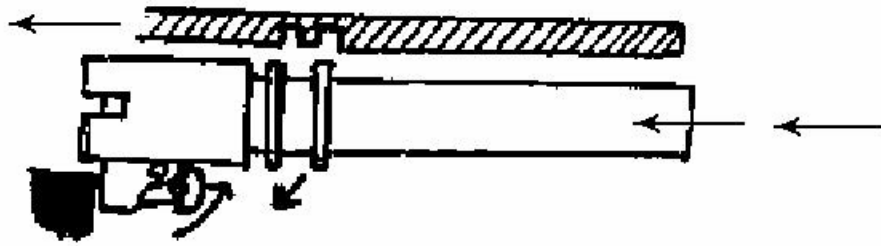

(
(
(



(

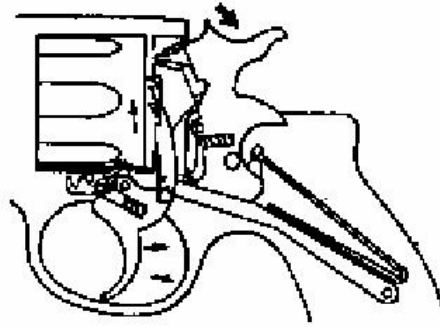

(

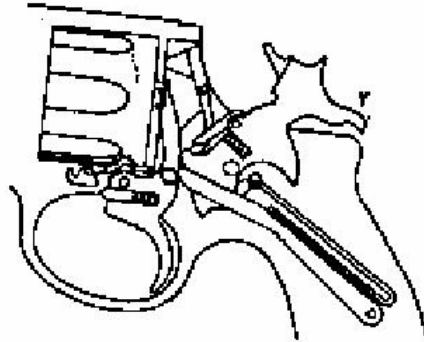

(

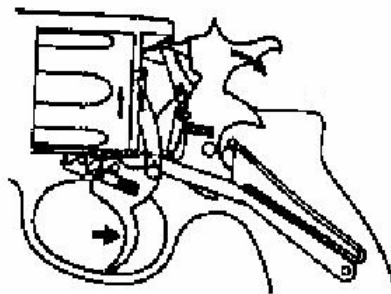

(

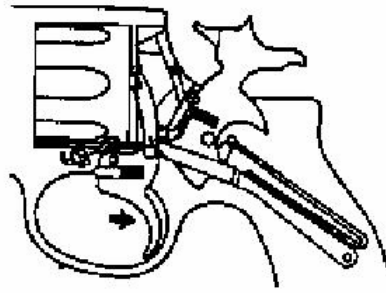

:

:

:

)

(

:

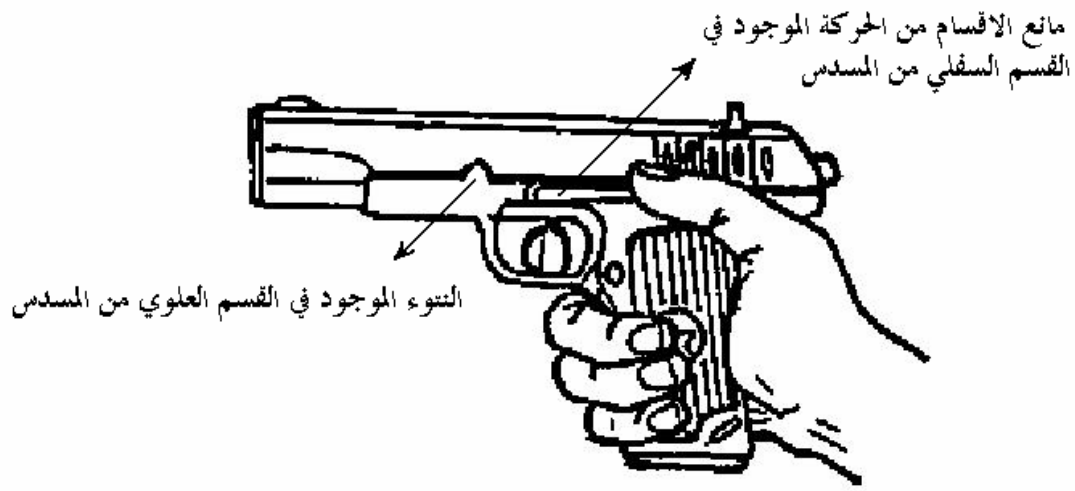

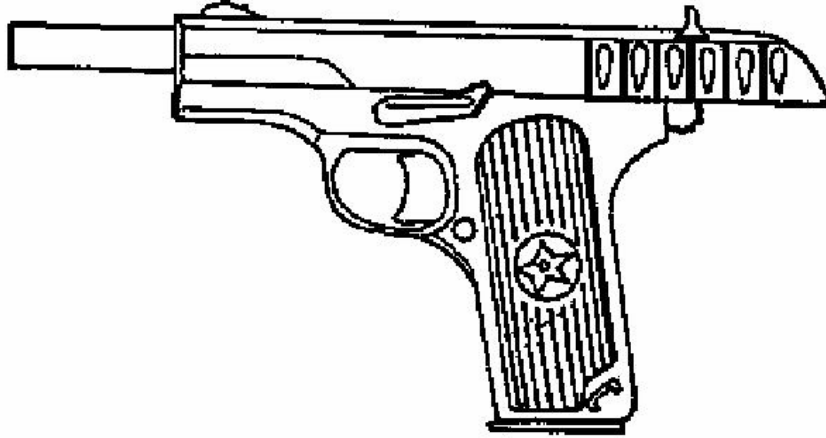

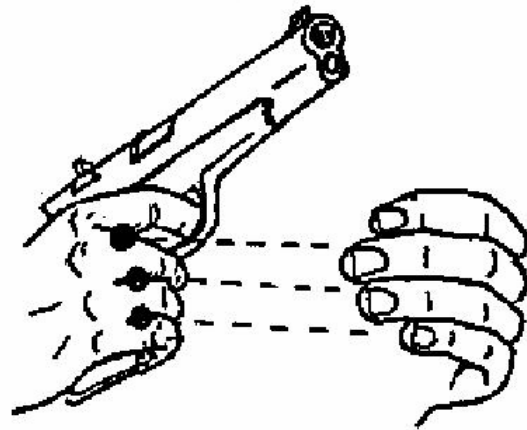

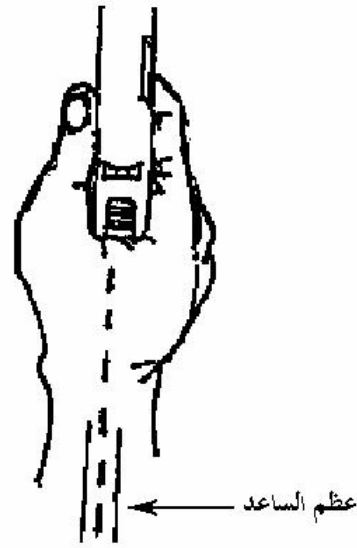

:

() .

:

(

(

()

(

(

:

(

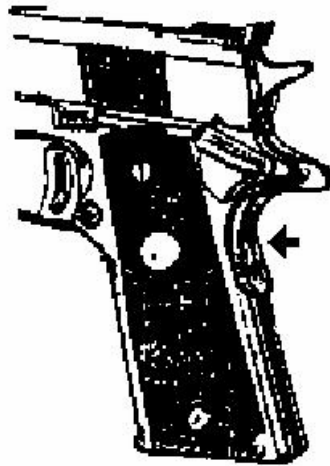

(

(

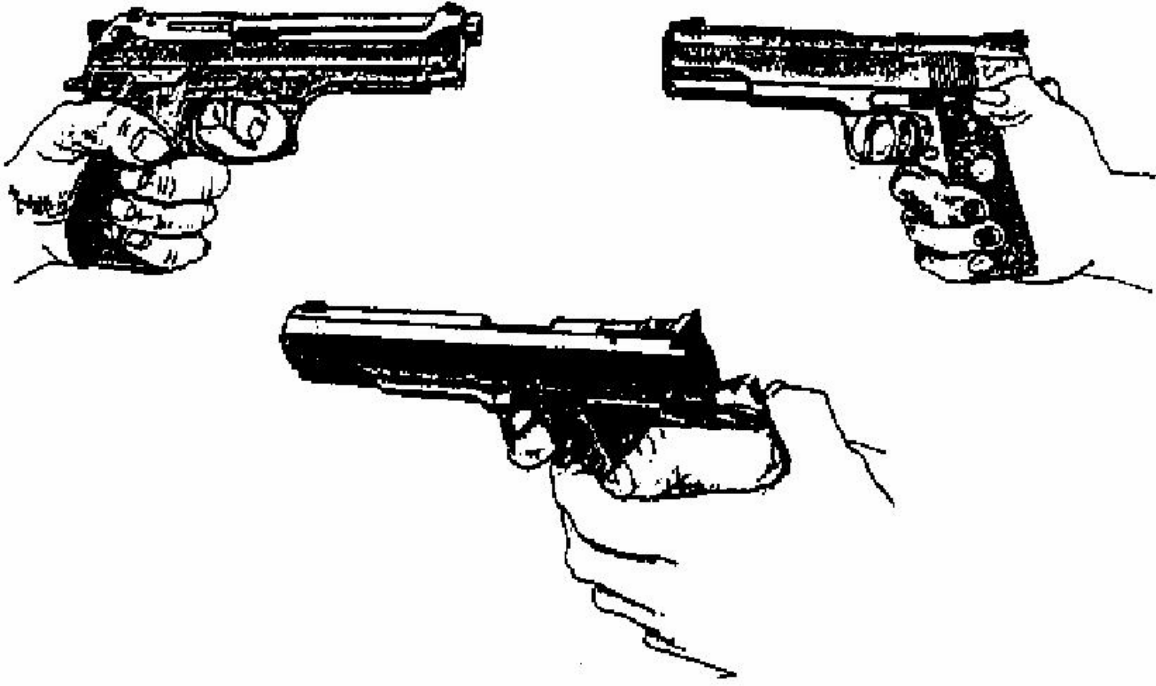

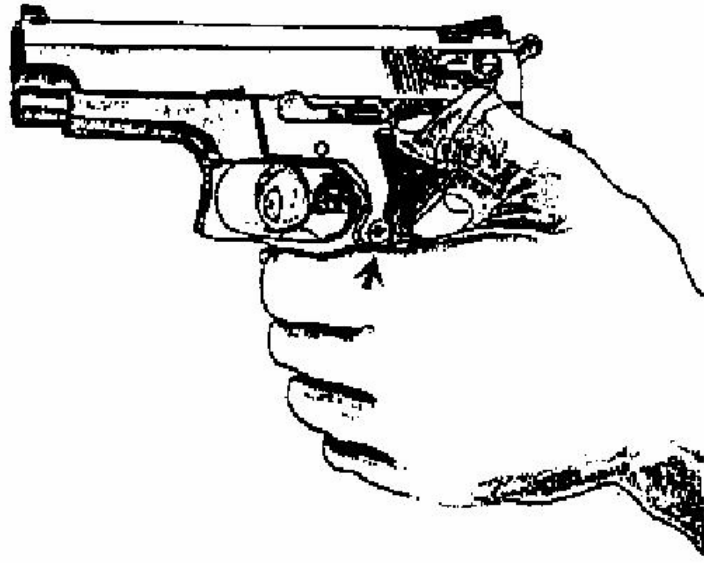

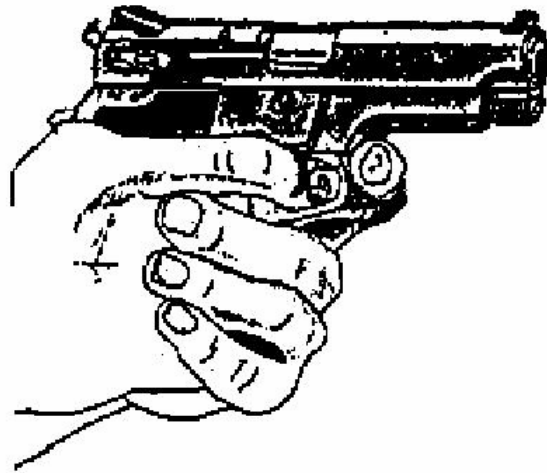

()



)

()

(

.
()



.()

()

(

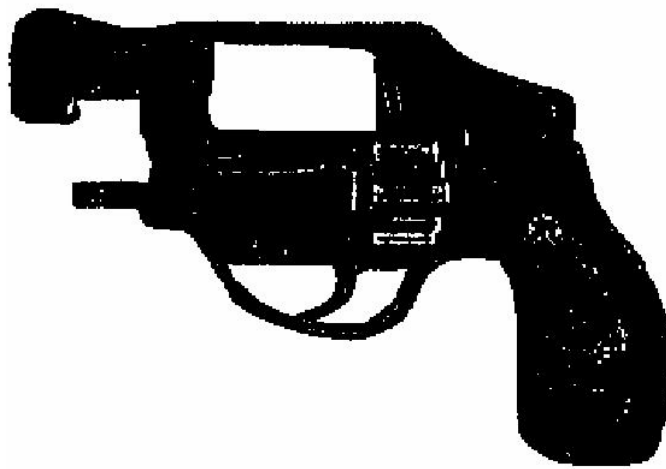

()

(





)

.(

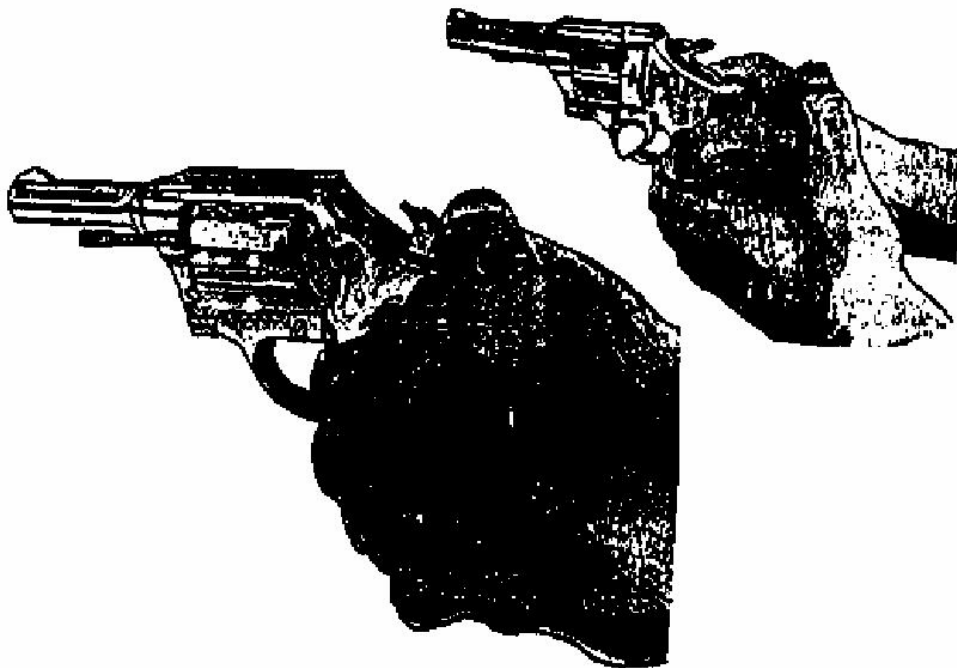

()



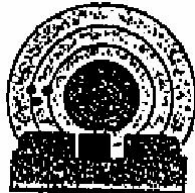
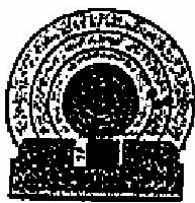
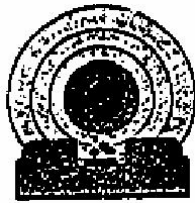
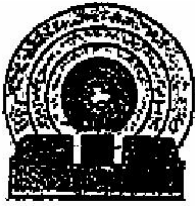

■

■

■

■

■

:

▪

▪

▪

▪

▪

()

:

()

▪

▪

)

.(

-
-
-
-
-

شهيق
زفير

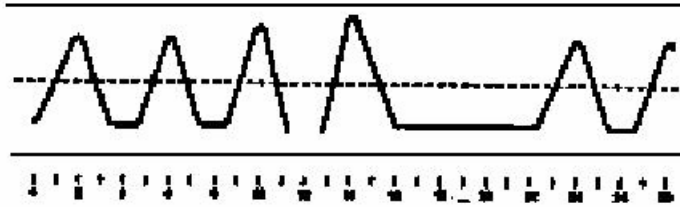

()

:

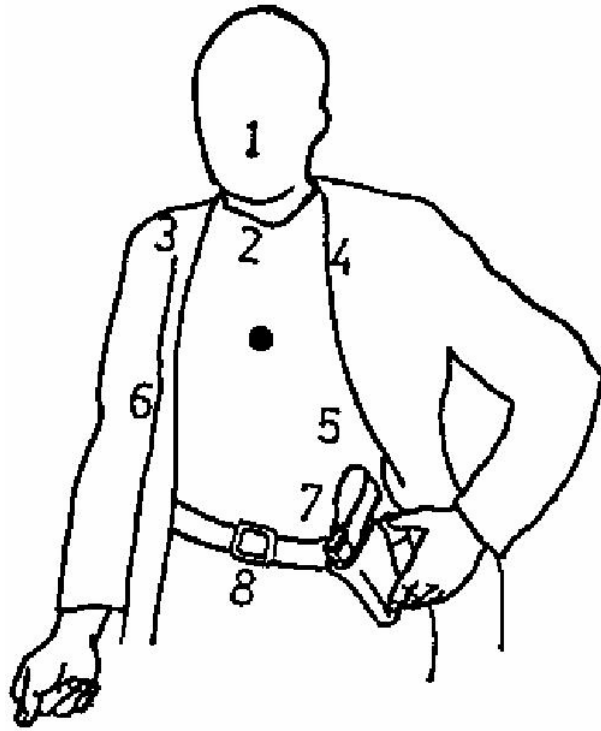

-
-
-
-
-
-
-
-
-

:

%

▪

▪

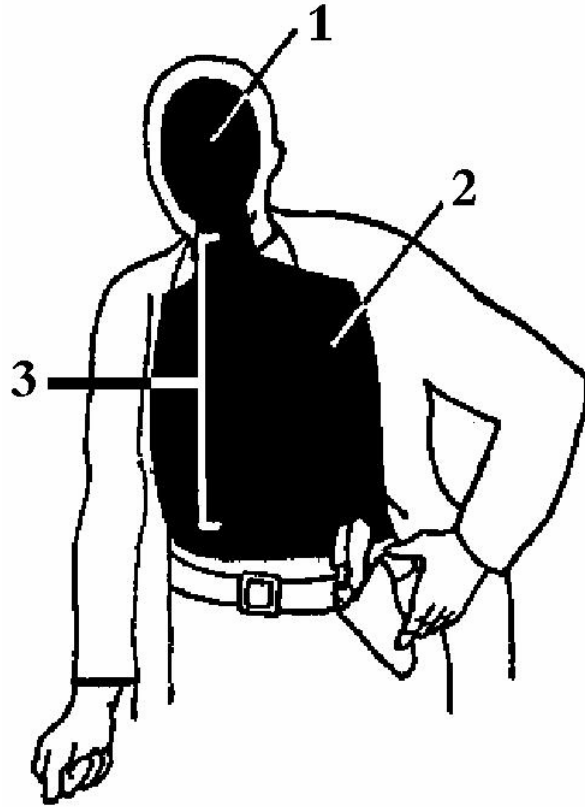

(

:

(

()

()

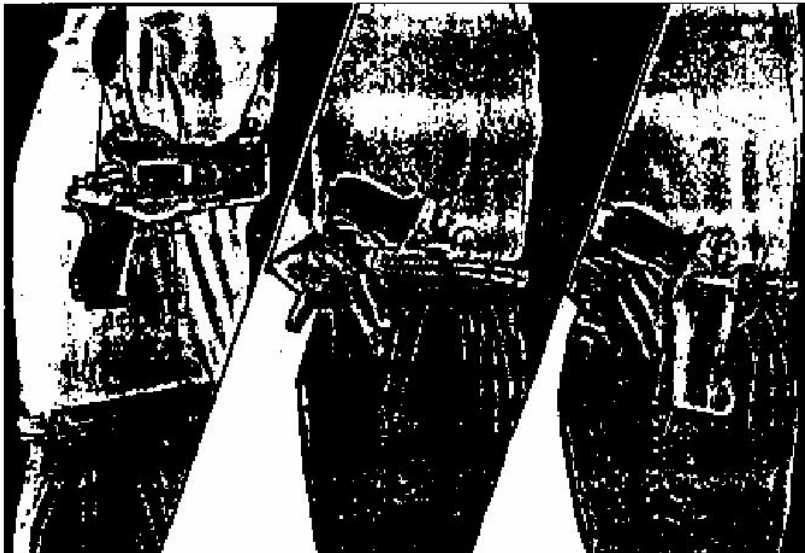



()

L

()

()

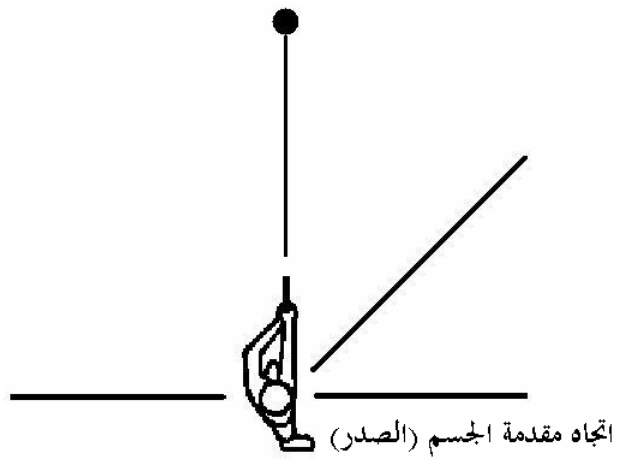

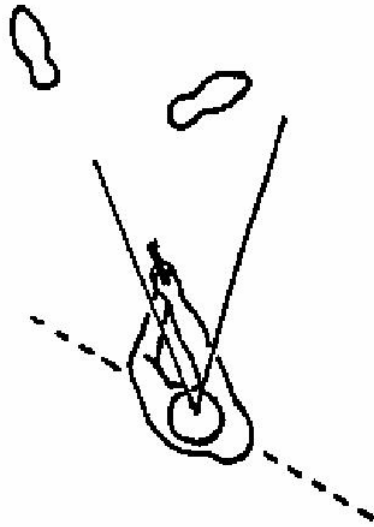

(L)



.()



L

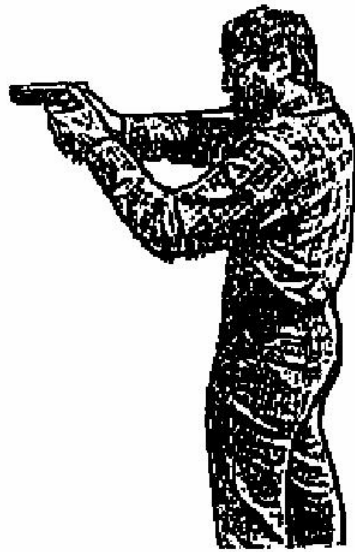

()

▪

▪

▪

▪

()

()

:

▪

- - :

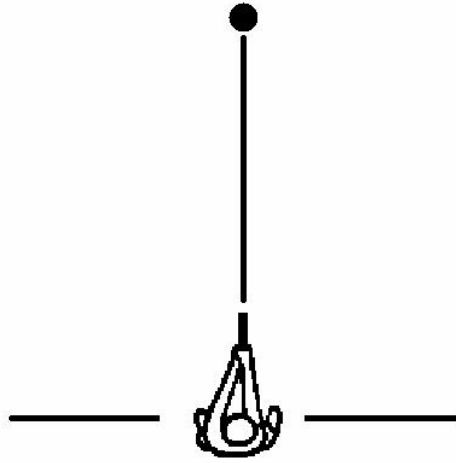

()

()

(

(

(

(

)

(

(

(

(

(

(

(

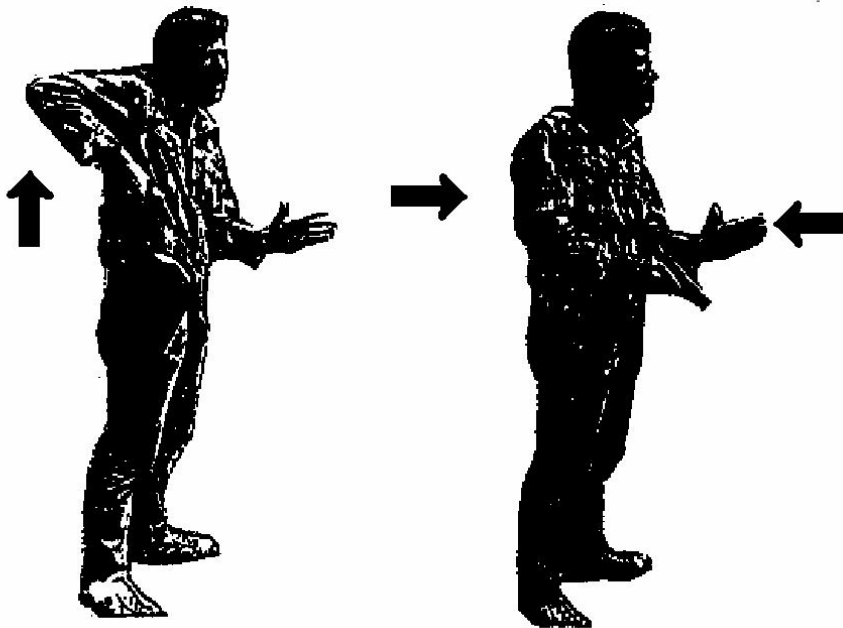



(



(



(



(



(



(

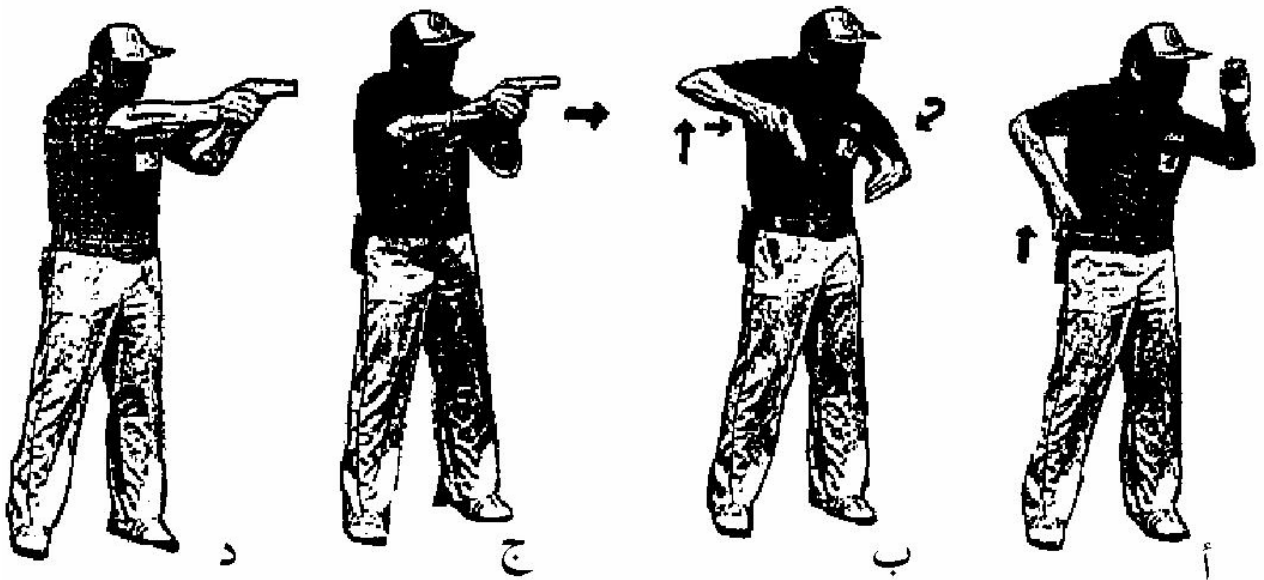

(
(
(
(

-
- -
 -
 -

(

(

.(

(

.()

(

)

.(

:

(

(

:

(

:

(

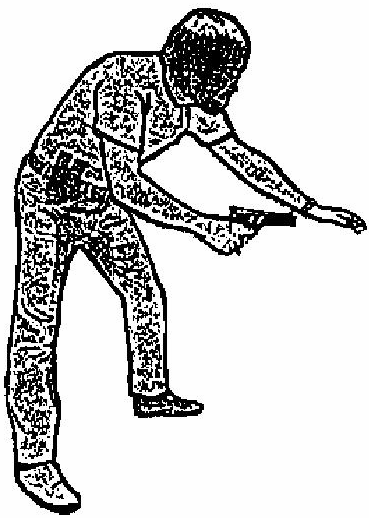

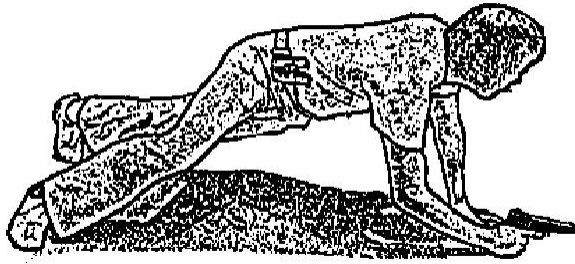

(



(

)

.(



(

()

-
-
-
-

() ()

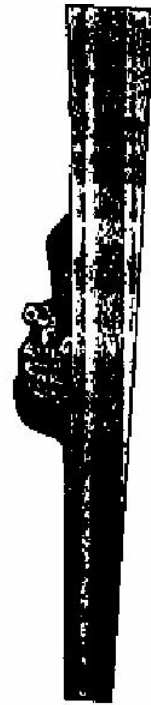
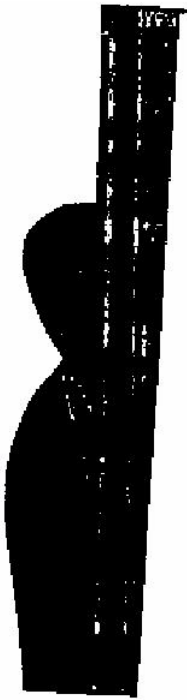

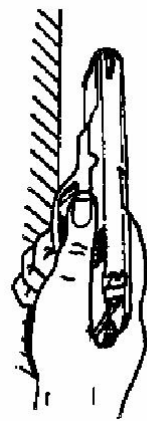
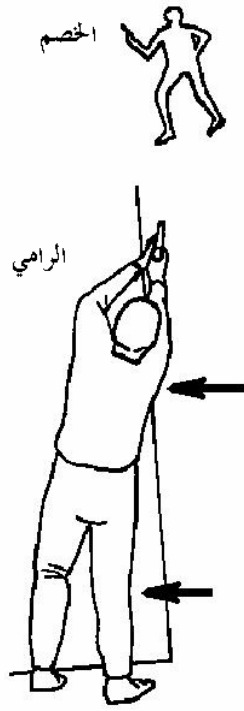

() .

:



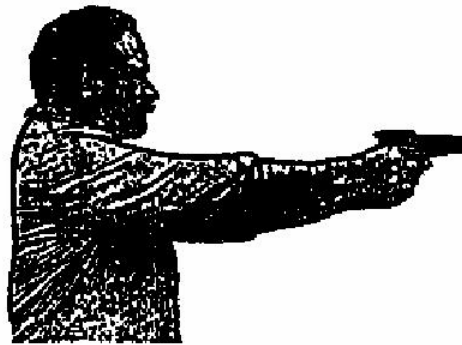

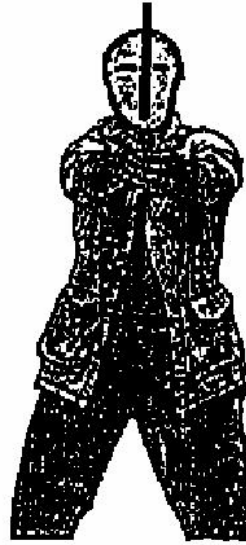
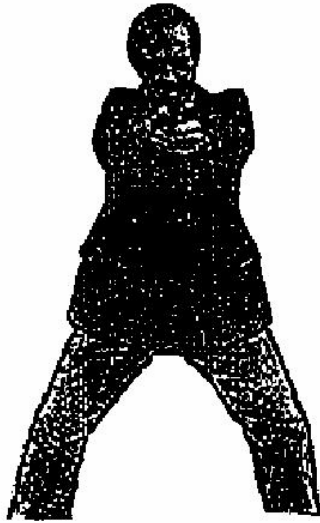

()

:

()

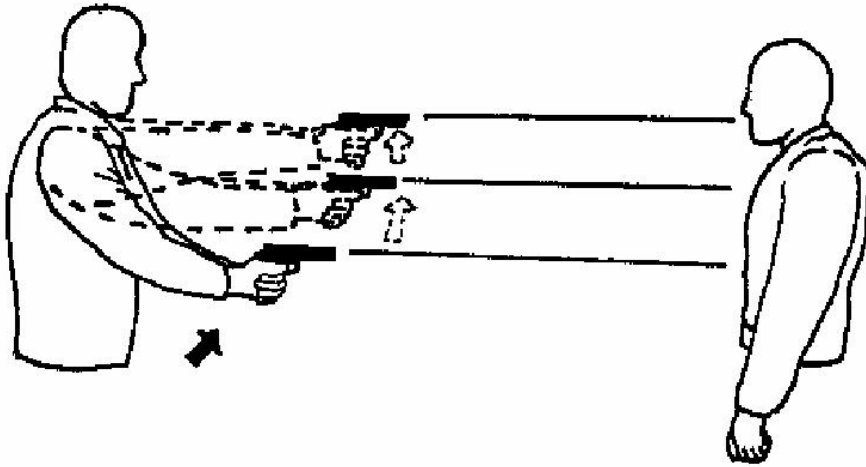

()

· - ▪
· ▪
)

· (

⋮

⋮ ▪

▪

()

()

·

·

▪

⋮

▪

▪

▪

▪

▪

▪

⋮

()

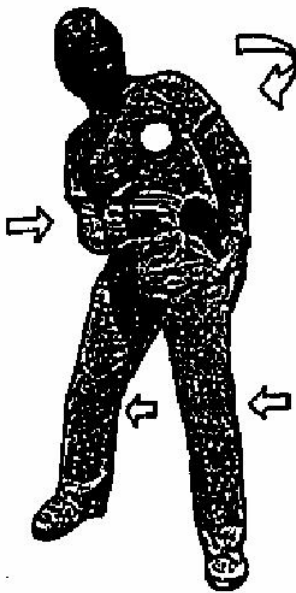
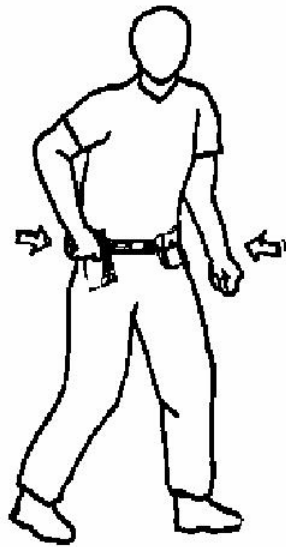

)

(



.()



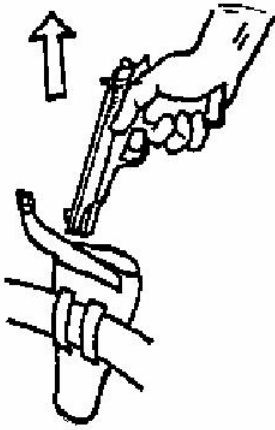

(



)

(

(



(



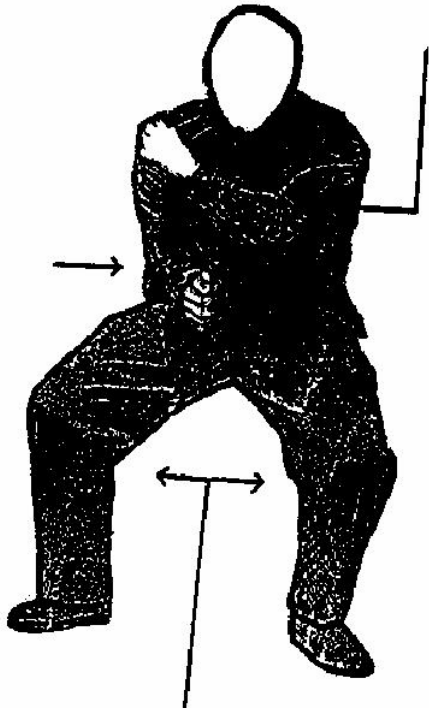

() .

(

(

(

(

(

(

()

(

()

(

(

()

()

(

(

(

(

.(()

.(()

(

: _____



٣



٢



١

(

(

(

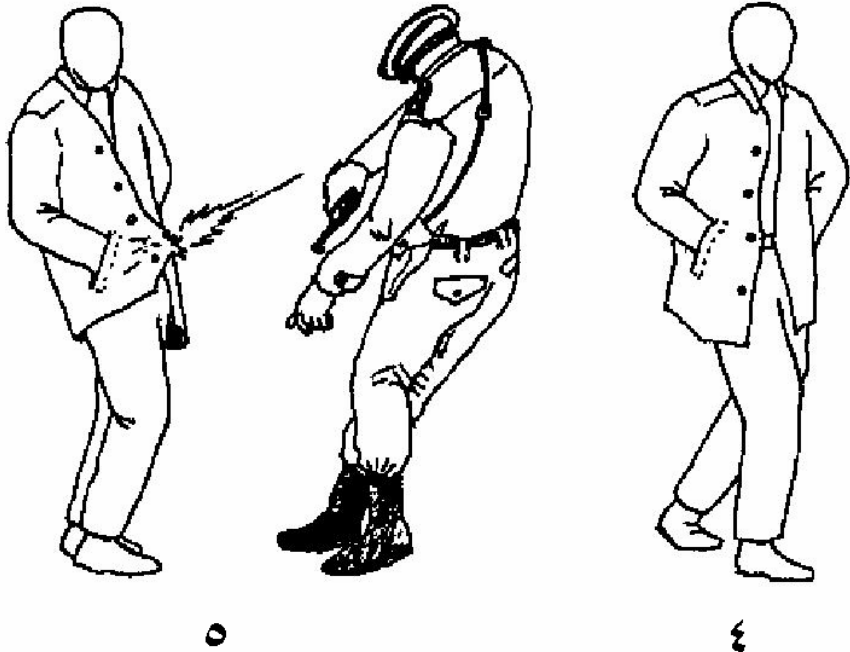

(
(



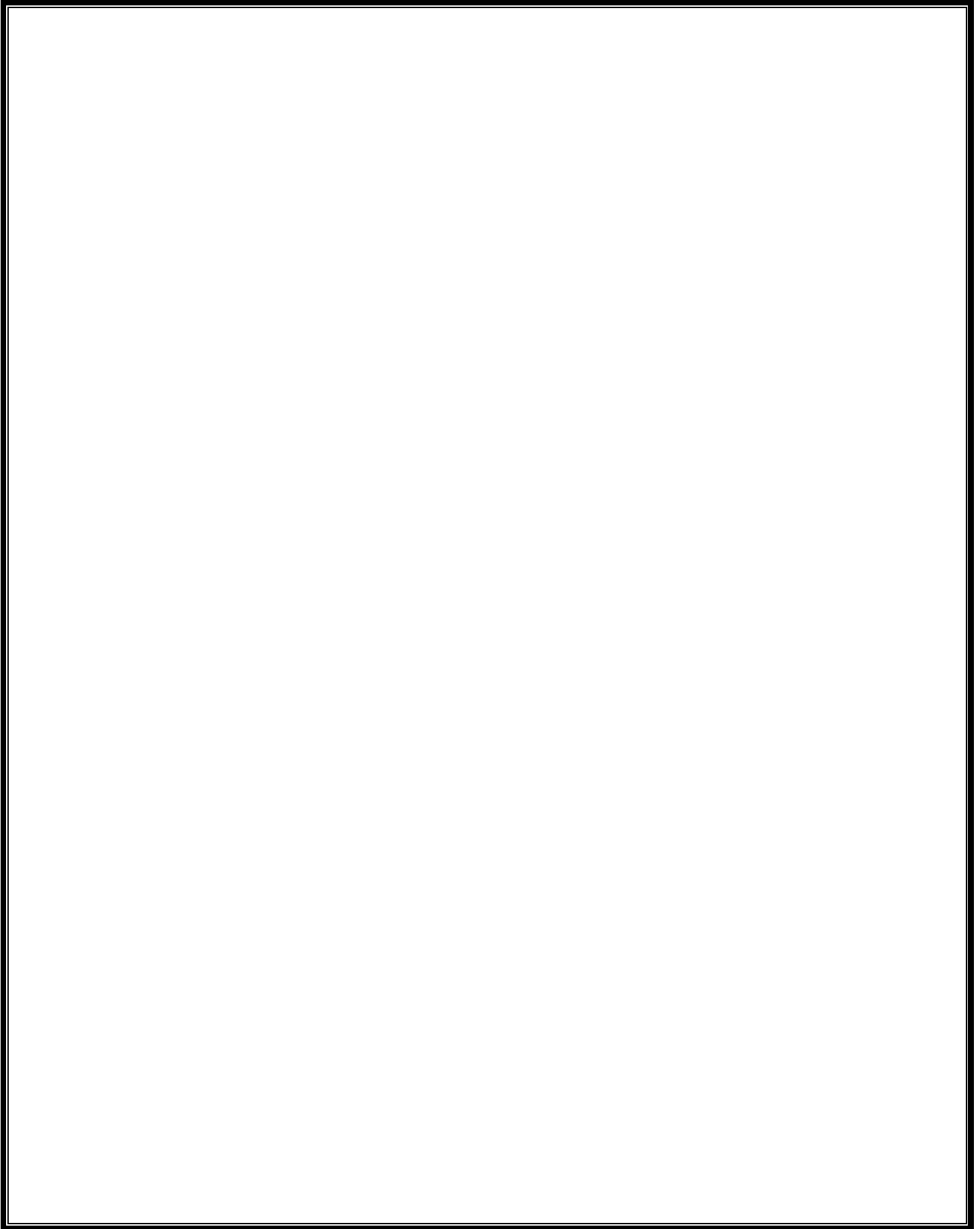

()

()

%

-
-
-
-
-
-
-

:

:

.

-
-

-
- -
 -

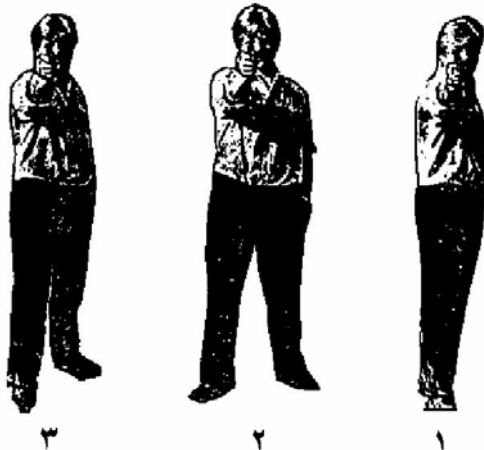

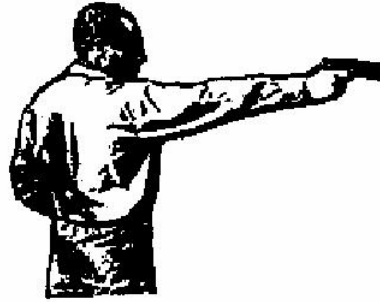

▪

▪

▪

▪







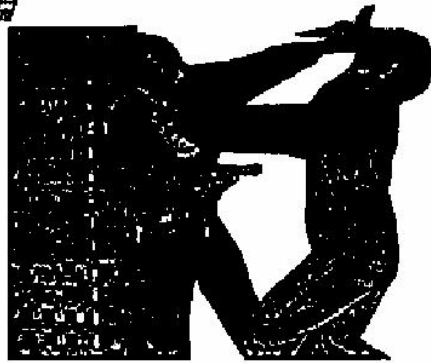
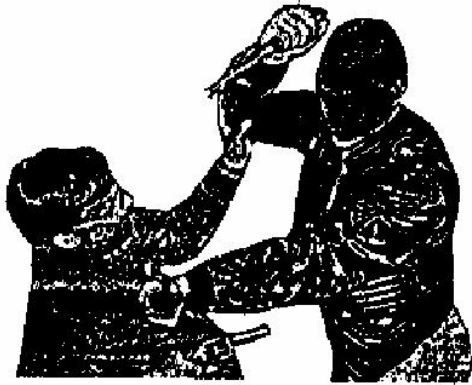

(

(

(

(

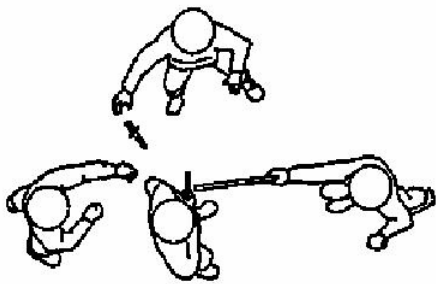

وضعية صحيحة

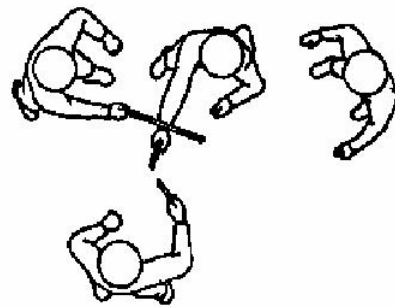

وضعية خاطئة

(



(



(

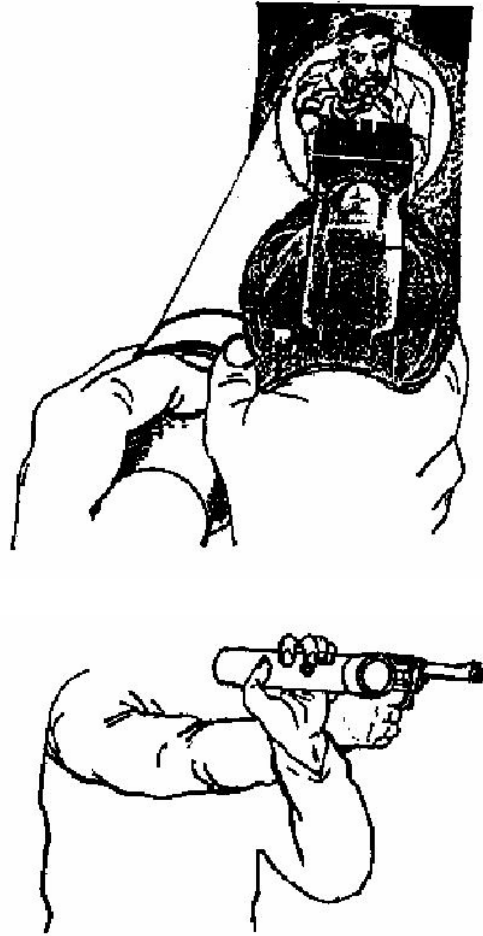

(

:

()

▪
▪

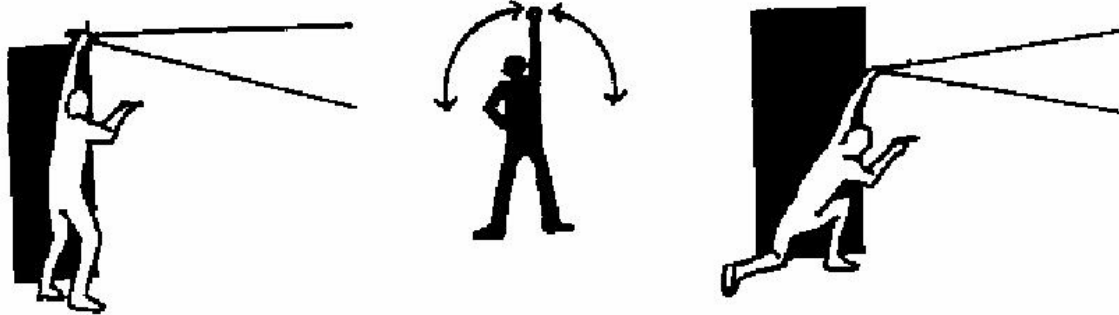

(

(

(

(

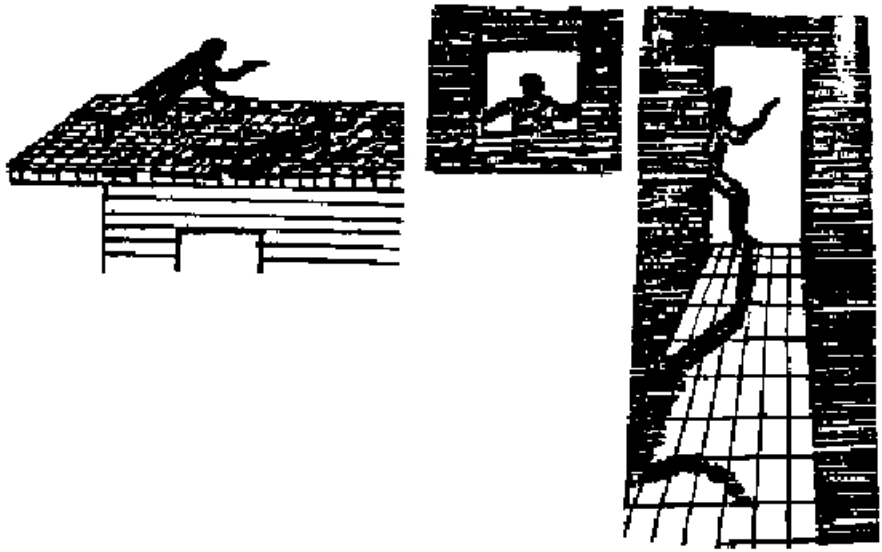

(



(



(



(

:

(
(
(
(
(
(
(

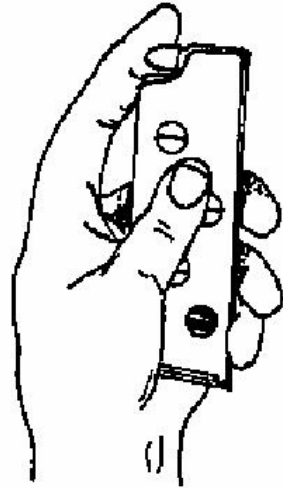

(
(
(



(
(



:

:

(

/

:

(

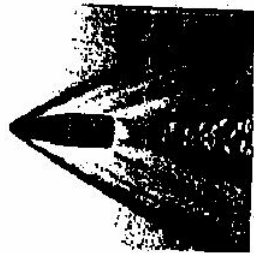

:

(

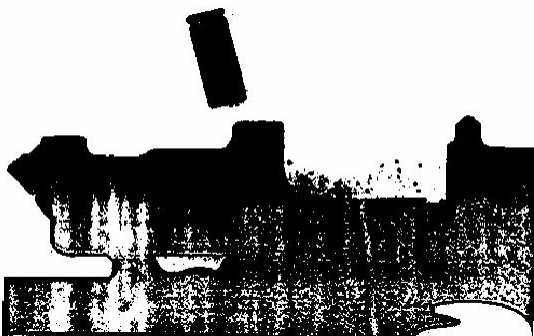

: :

:

{ } + × =

.

.

.

:

()

:

.

.

()

.

%

-
-
-
-

(/)

:

:

:

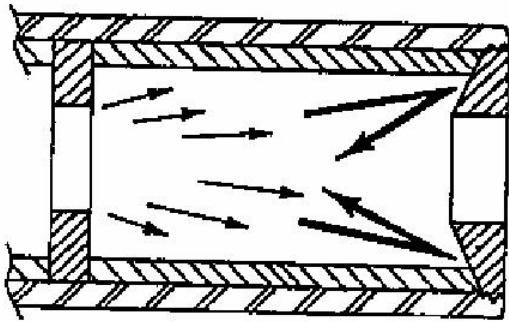

:()

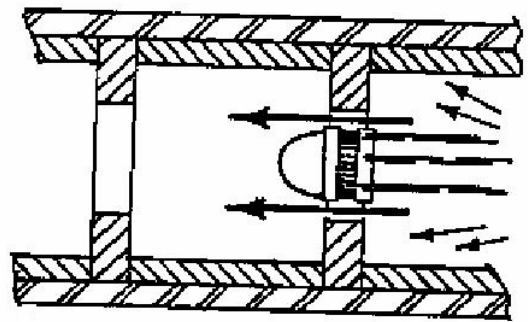

:()

(
.

:

:

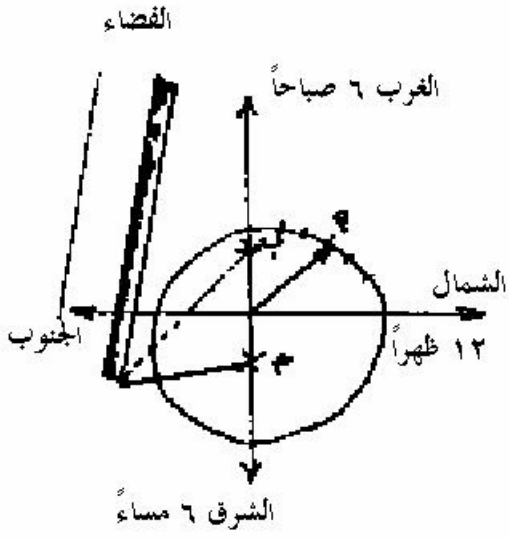

-
-
-
-

- ١. ()
- ٢. ()
- ٣. ()

-
-
-
-
-
-
-

:

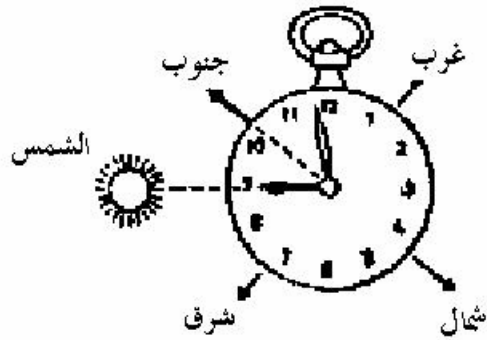

-
-
-

:

W

:

-
-
-

.(-) :

.() :

.() :

.() :

.() :

.() :

.

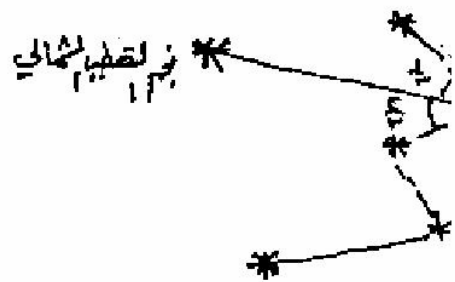
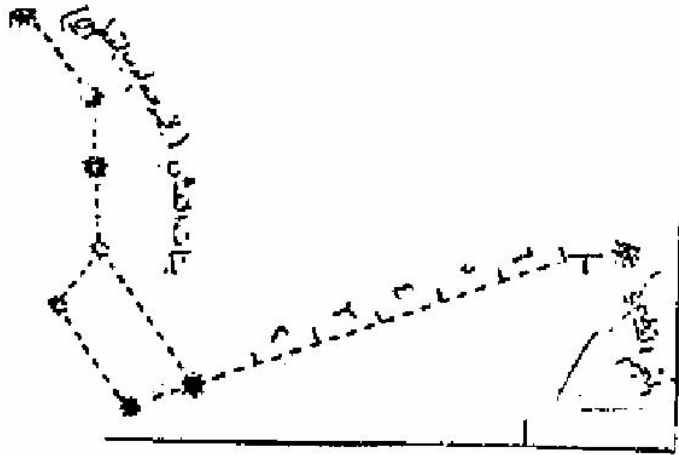

()

ا ك م
 —————
 مصغر

ا ك م
 —————
 مكبر

:()

() =

:

(:)

.

.

⋮

. = ×

:

:()

:

⋮

:

(
(

:

(
(
(
(
(

(
(

:

(
(
(

. = (/ ,) = (/)

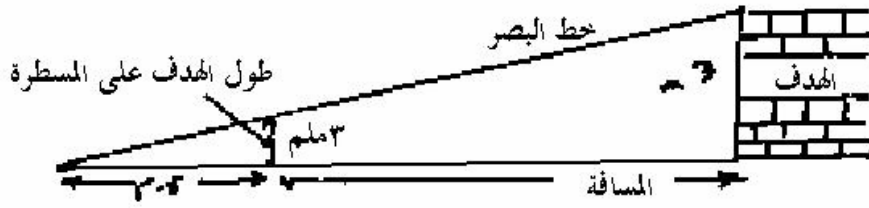

$$\div () \times () = ()$$

$$= ((\times) / (\times \times)) = (, \div , \times) =$$

(

(

(

(

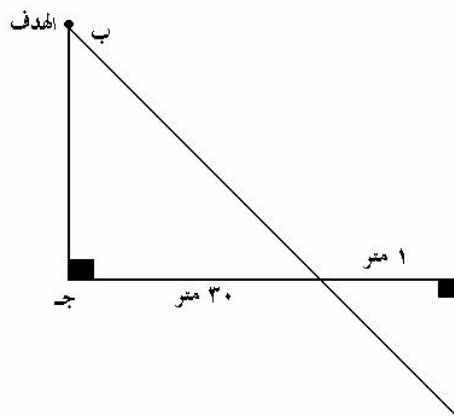

$$= \times$$

$$=$$

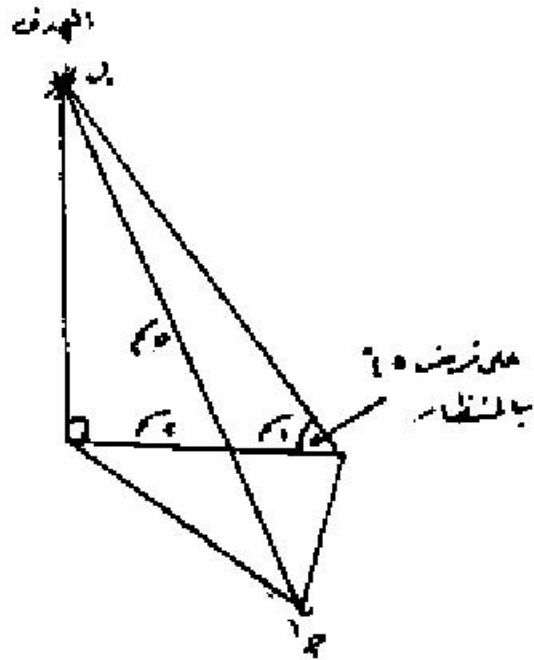

=

(:)

_____ : .

() ()

:
(
(
(

. (÷) =

. (÷) =

. × = . ÷ = =

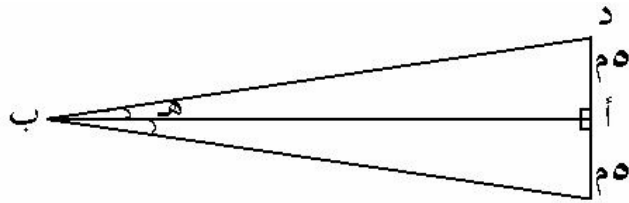

: (

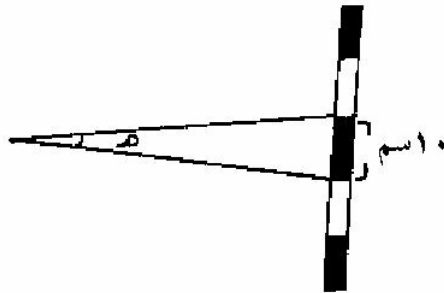

: ,

. ÷ =

. ÷ =

. / , (

: (

: (

. = (

. = (

(
(
(

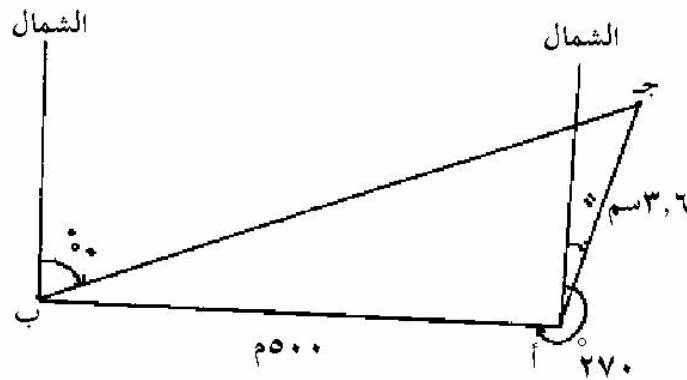

.(:)

_____ (

_____ (

. : (

()

.()

()

: (

.()

: (

()

.()

: (

(

:

(

(

(

(

(

(

(

(

()

(

(

(

(

(

(

(

(

(

(

- :
- :
- :
- :

- :
- :
- :
- :

()

:

:

:

()

:

(

(

(

(

(

(

:

:

(
(
(
(
(
(
(

:

(
(

(

:

■

:

:

:

▪

:

▪

:

▪

:

▪

:

▪

:

▪

()

- :
- :
- :

(
(
(

:()

:

(
(

= - (

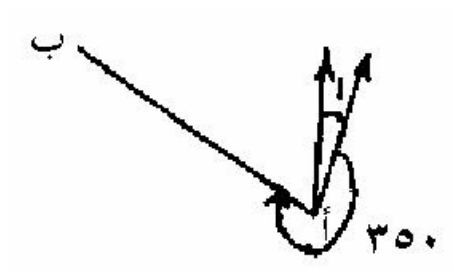

:()

=

:

(

= +

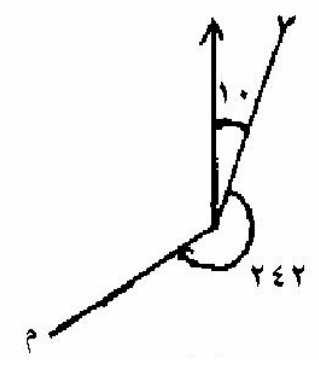

(

:

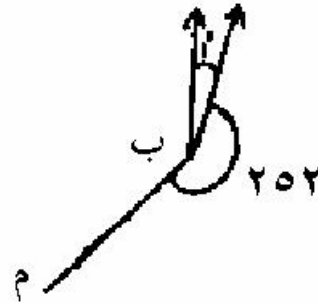

= -

(

(

(

(

:

()

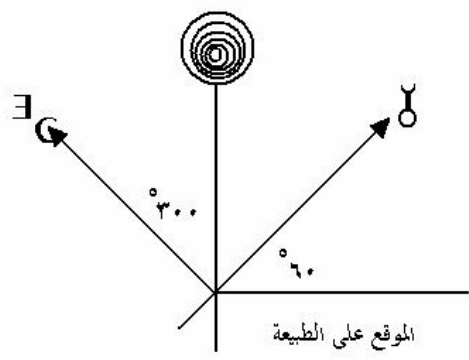
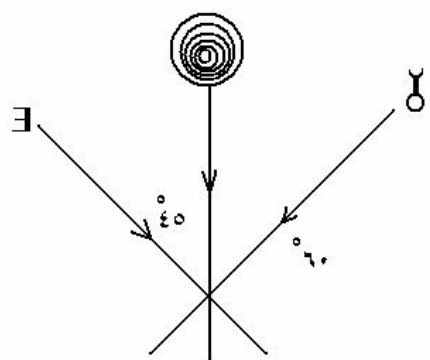

: () (

:

(
(
(

- - - :

()
)

(

:

.

.

.

:

$$. / = + (\times)$$



.

:

(

:
:
:

(

()

(

.

(

(

(

:()

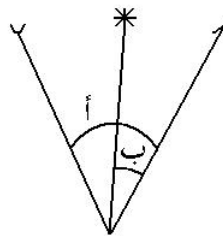
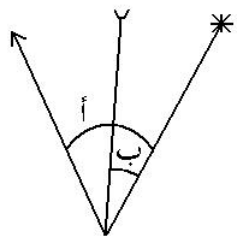

. () =

▪

. () =

▪

. () + () =

▪

:()

. () =

▪

. () =

▪

. () - =

▪

: ()

:

:

- = - ■
- () = × ■
- = - ■
- = - ■

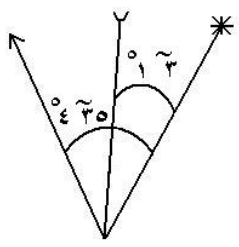

: ()

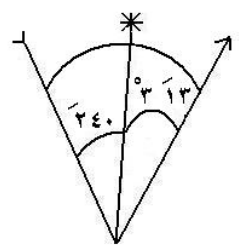

-
-

:()

)

(

:

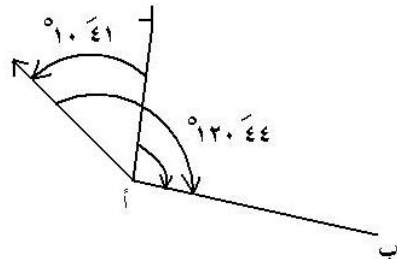

.

$$= +$$

$$a1 = a$$

$$Ga = a2$$

$$Da - Ma$$

$$(Ga +) + a1 = a$$

$$(Ga +) - a = a1$$

$$(Ma +) - a = a2$$

:()

:
= +

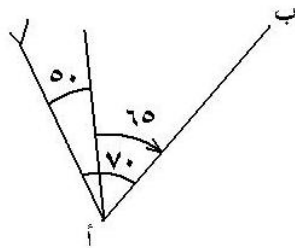

: ()

:
= ■
= ■
= + ■
= - ■

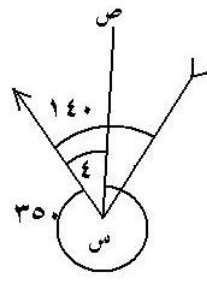

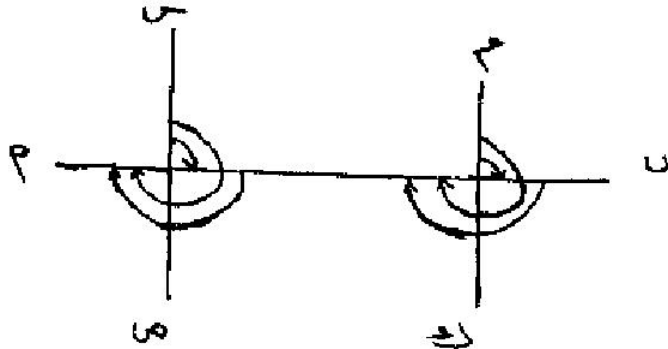

$$\begin{aligned}
 & \dots = \dots \\
 & \dots + \dots = \dots \\
 & \dots = \dots \\
 & \dots + \dots = \dots \\
 & \dots = \dots
 \end{aligned}$$

$$\begin{aligned}
 & \dots + \dots = \dots \\
 & \dots - \dots = \dots
 \end{aligned}$$

$$\dots (\dots - \dots - \dots)$$

- (
- (
- (
- (

()

(

(

(

(

Scale

.Direction

Location

,)

(

()

-

()

()

()

()

()

() ()

:

(: .

(: .

(: .

(: .

(: .

(: .

(: .

(: .

_____ : .

/ .

/ .

/ .

:

(

(

:

(

(

(

(

(

(

(

(

(

:

(

(

()

)

(

)

.(

:

(

)

(

(

.

(

.()

(

(

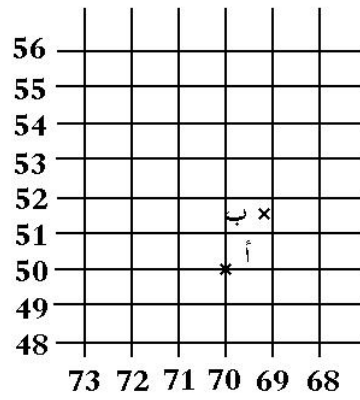

()

▪

()

▪

: (

: (

: (

: (

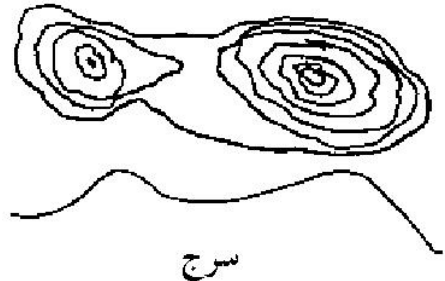

(:

(:

(:

(:

(:

(:

(:

(:

(:

(:

(:

(:

(:

(:

(:

(:

(:

(:

)

:

:

- / ▪
- / ▪
- / ▪
- / ▪

()

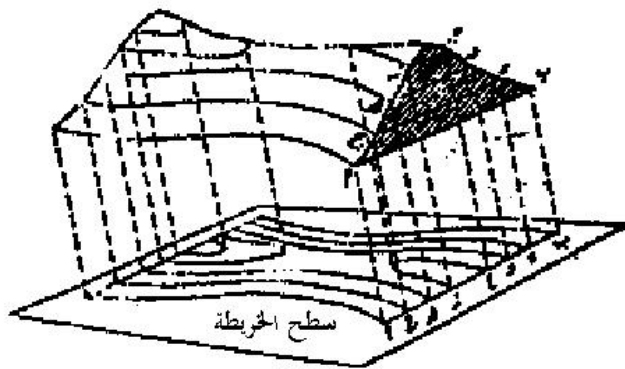

/

/

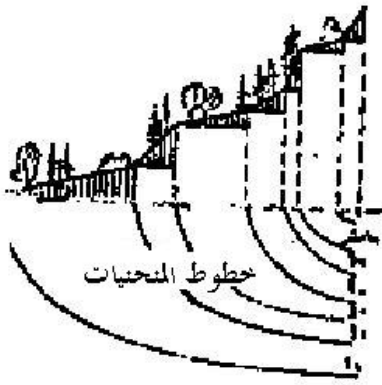

فرق الارتفاع بين منحنى وآخر ١٠ أمتار

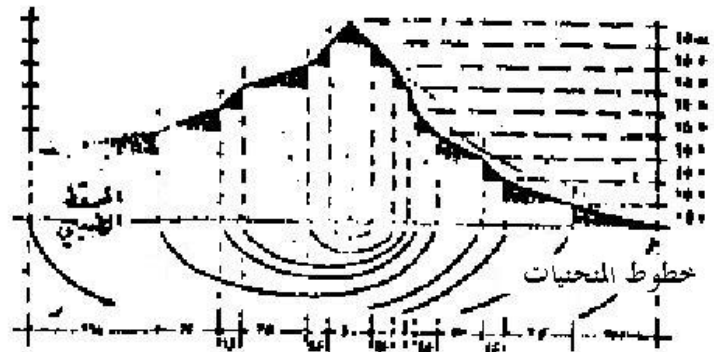

إن الفارق بين منحنين يقور درجة الميل

:

(

(

(

:

/

() .

(
(
(
(
(
(
(
(
(
(
(

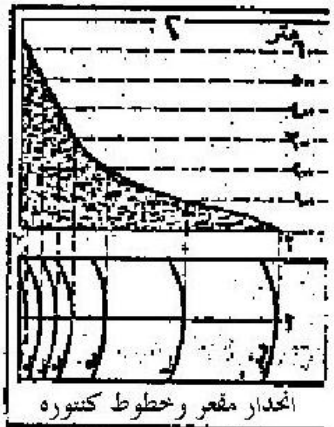
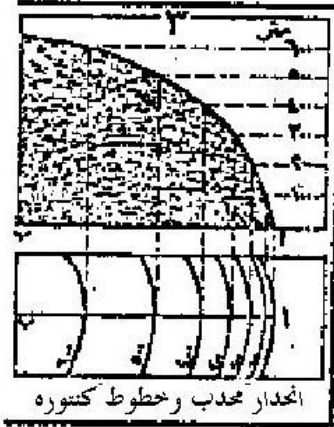
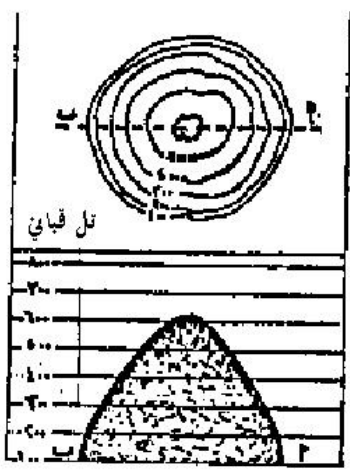
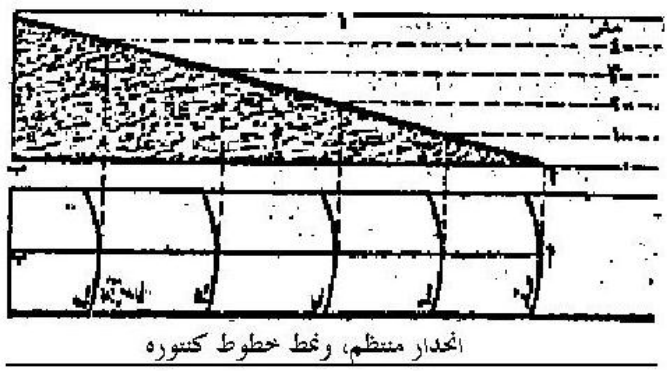
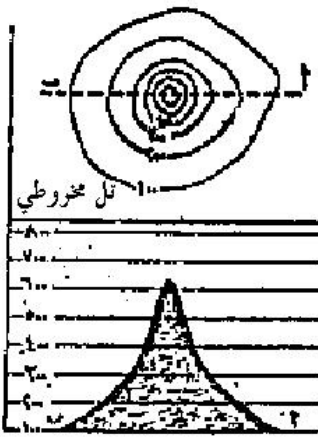

أشكال من انحدار سطح الأرض ، ونمط خطوط كنتورها

:

(
(

. (= -) =

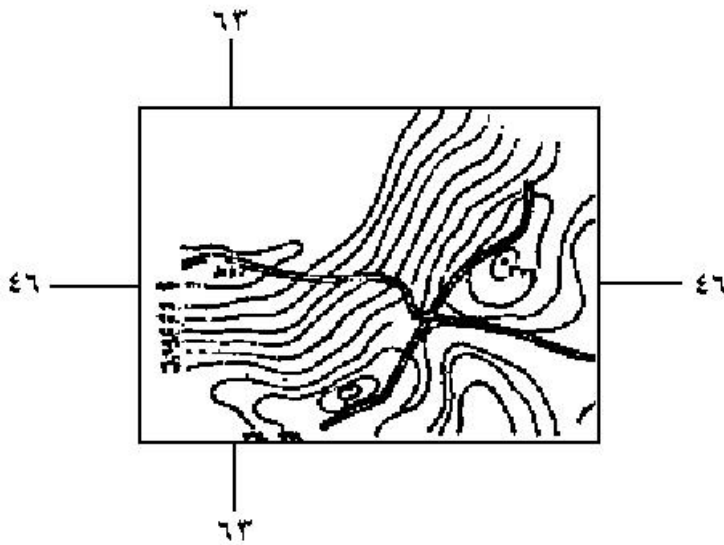

:

÷ = (, ÷)

-
-
-

. ()

(...)

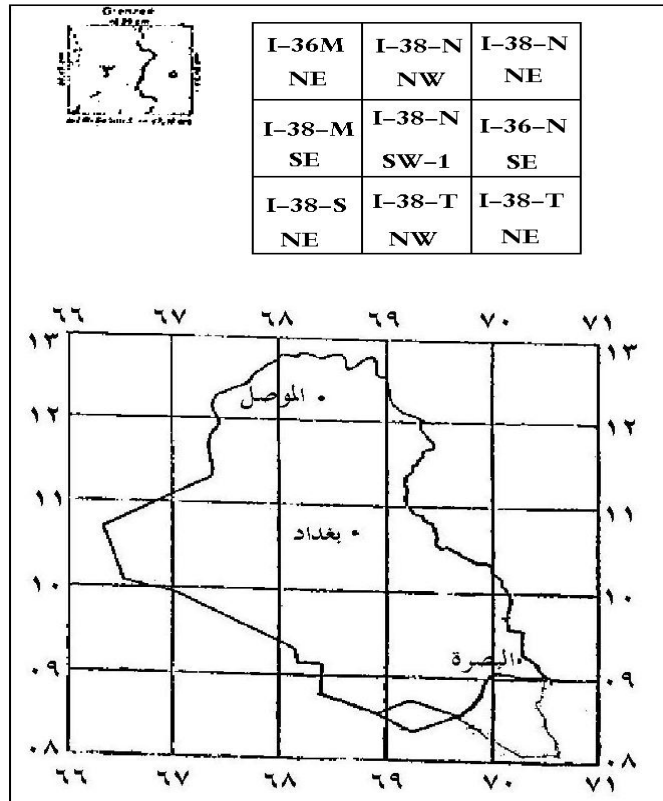

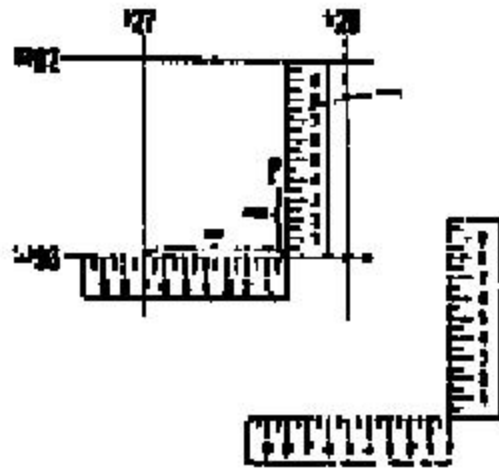

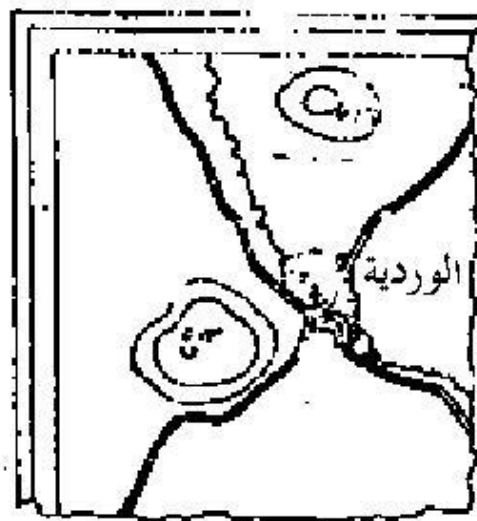

خارطة الوردية ١/٥٠٠٠٠

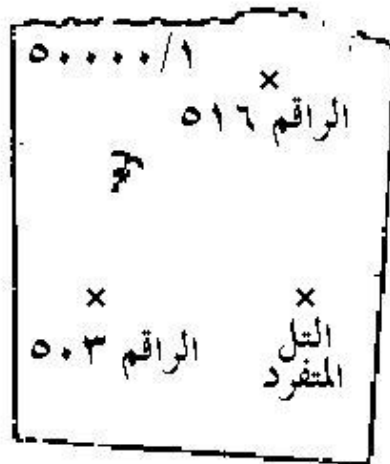

الشفافة

(
(
(

:

()

:

:

()

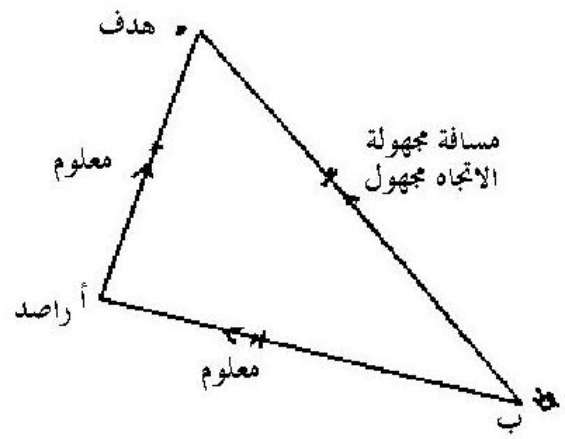

:

:

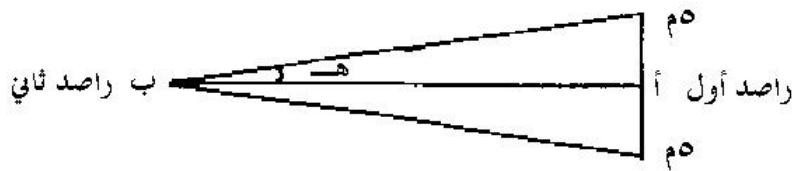

$$\begin{aligned}
 & \dots + () = (\\
 & \dots () + = \\
 & \dots + =
 \end{aligned}$$

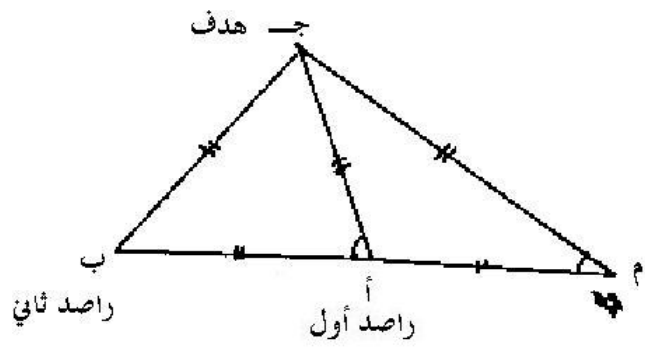

$$\begin{aligned}
 & \dots () \\
 & \dots ()
 \end{aligned}$$

:

:

(

(

(

(

AC 7 KIN1 KIN2 KIN3 KIN4 KIN5 MODE EXP P3 (KOUT4 × KOUT3 COS
 OUT5 × KOUT3 SIN) + KOUT1 = SHIFT HLT (KOUT3 SIN + KOUT5 ×
 KOUT3 COS) + KOUT2 = SHIFT HLT MODE.

- KIN1 ---- $X_0 = 0$. (,)
- KIN2 ---- $Y_0 = 0$
- KIN3 ---- $Q = 36.86$.
- KIN4 ---- $X_n = 0$.
- KIN5 ---- $Y_n = 5$.

- P3 ---- $X = -3$.
- RUN ---- $Y = 4$.

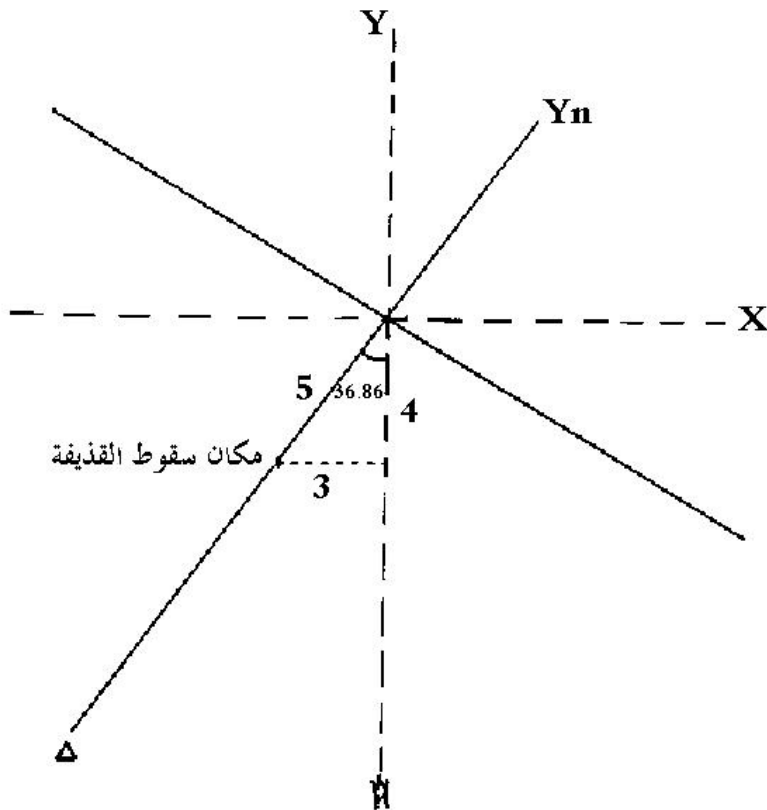

FX

AC 11 KIN4 KIN5 KIN6 MODE EXP.0 P1 KOUT4 \times^2 + KOUT5 \times^2 - 2 \times
 KOUT4 \times KOUT5 \times KOUT6 COS = SQR INV HLT KIN1 KOUT4 \times KOUT6
 SIN \div KOUT1 = INV SIN⁻¹ INV HLT KIN2 180 - KOUT6 - KOUT2 = INV
 HLT MODE.

- KIN4 ---- 306.417772
- KIN5 ---- 200
- KIN6 ---- 60
- P1 ---- 269.4582711
- RUN ---- 80 .()
- RUN ---- 40 .()

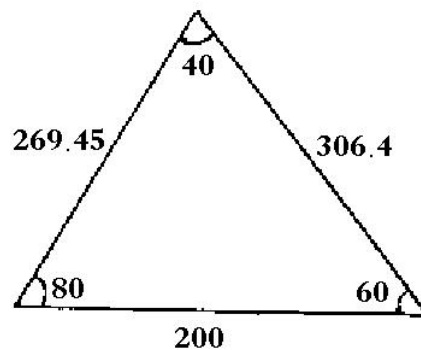

()

- 10 INPUT "A" ; "B" ; B "D" ; D
- 20 C = 180 - A - B
- 30 E = D * SIN A / SIN C
- 40 F = D * SIN B / SIN C
- 50 PRINT "C" ; C, "E" ; E, "F" ; F
- 60 END

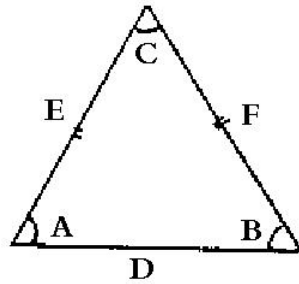

CASEO 3800F

-

AC 7 KIN1 KIN2 KIN3 MODE O P1 180 - KOUT1 - KOUT2 = KIN4 INV
 HLT KOUT3 + KOUT4 SIN = KIN5 × KOUT1 SIN = INV HLT KOUT5 ×
 KOUT2 SIN = INV HLT MODE

- KIN1 ← 46 ()
- KIN2 ← 130 ()
- KIN3 ← 150

- P1 → ()
- RUN → ()
- RUN → ()

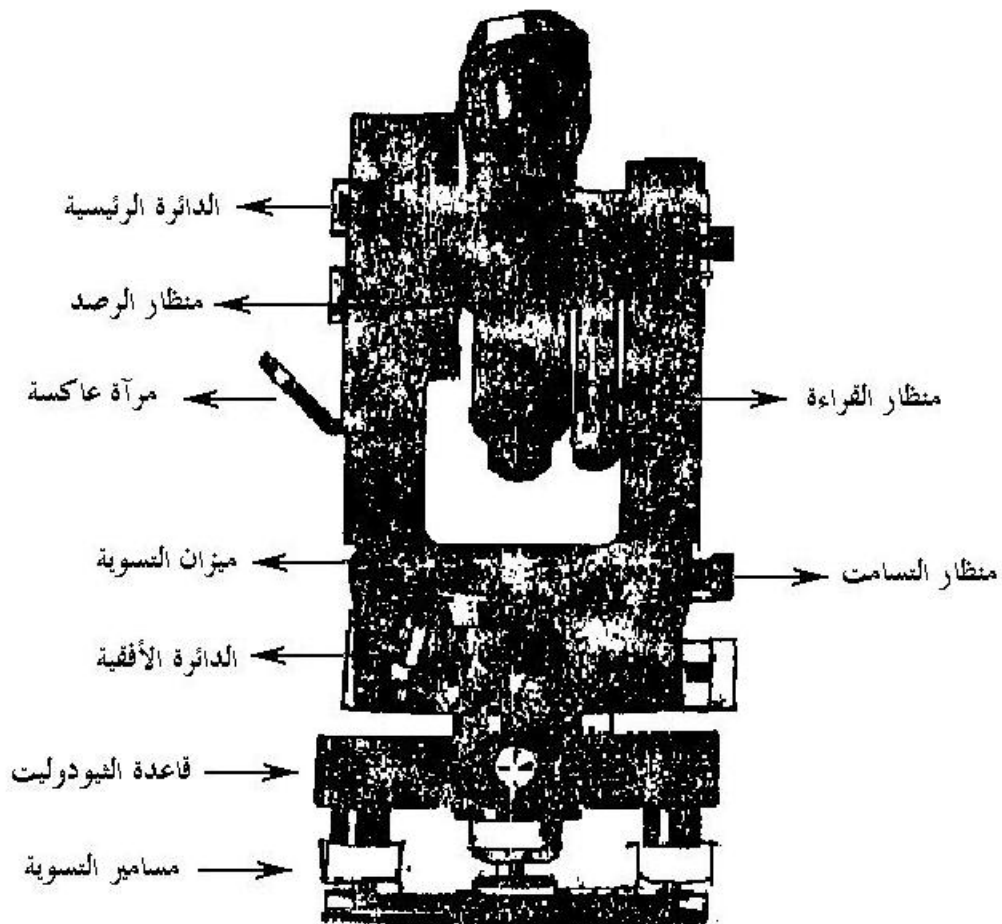
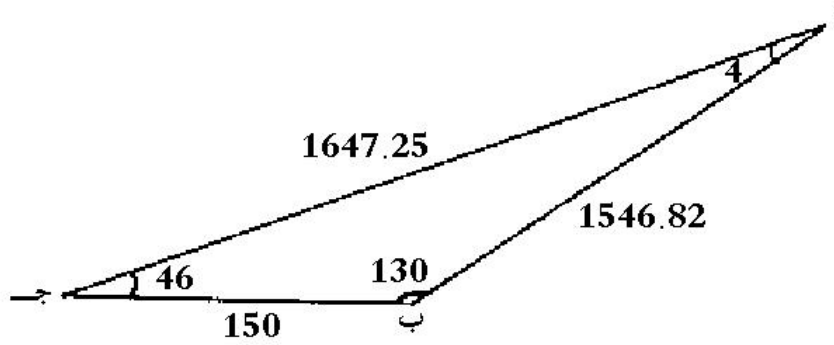

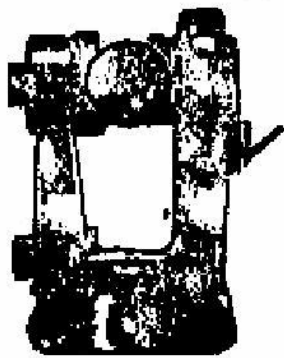

شكل رقم (٤٠)

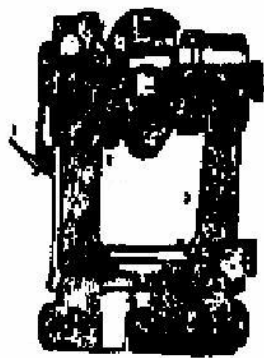

شكل رقم (٣٩)

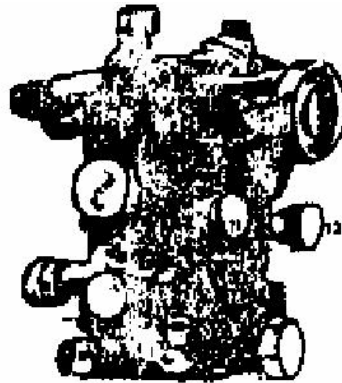

شكل رقم (٣١)

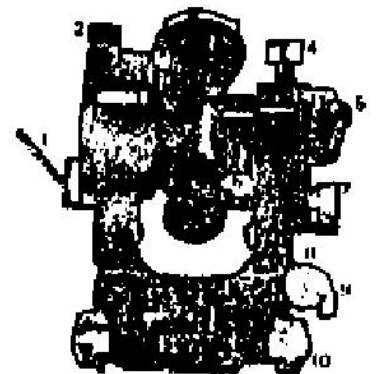

شكل رقم (٣٠)

DKM 1 :

:

(

(

(

(

(

(

(

(

(

(

(

(

(

(

(

(

(

(

.(

)

.

.

.

.

.

.

.(

)

.

.

.

.

.

.

:

.

:

(

()

. (+)

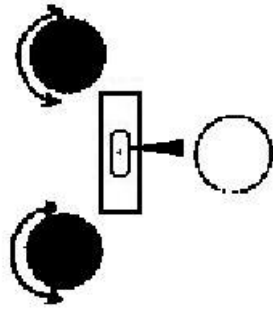

أ

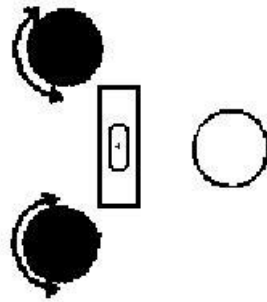

ب

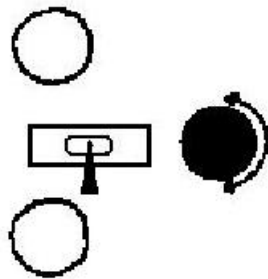

ج

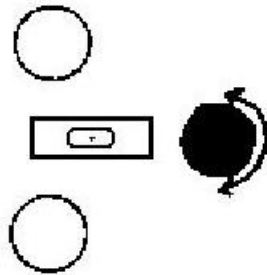

د

()

(

(

)

(

()

()

(

()

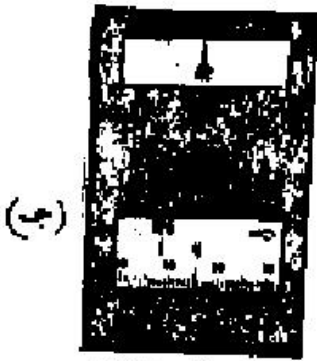

418° Vertical circle
82° 57' 30"



368° Vertical circle
72° 30' 30"



400° Horizontal circle
Clock scale
170° 65' 30"

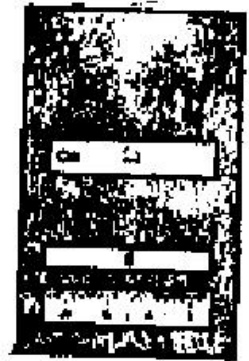

360° Horizontal circle
Counterclockwise scale
28° 12' 30"

()

()

)

(

()

()

()

(G)

()

.()

()

()

:

. ()

()

()

: (G)

()

: ()

(

(
(
(
(
(
(
(
(
(
(
(

()

(
(
(

:

:

()

()

(

(

(

(

()

()

()

▪

▪

▪

▪

()

.

■

:

:

(

)

:

(

(

)

(

:

(

:

(

:

.()

:

)

.(

(

(

(

	EXE RUN	
1RSD = 1 *** 2RSD = 2 ?		
	EXE 1	
RSID1, E, N, H ?		
	EXE 10 EXE 20 EXE 80	
RAMI, E, N, H ?		

	EXE EXE EXE	
Z, ITIGAH, MASAFI?		
HADF EXE SHR 10 EXE SHM EXE H EXE RAMI - TO - HDF EXE MASAFI = METER EXE ITTIGAH DARAGA EXE Z MILS EXE		
1- NEW RAMI EXE 2- NEW HADF EXE 3- NEW RAMI & HDF EXE 4- END EXE 5- CORREC EXE ? CHOOSE		
	EXE	
READY P1		

(

	EXE RUN	
1RSD = 1 *** 2RSD = 2 ?		
	EXE 2	
RSID1, E, N, H ?		
	EXE EXE EXE	
RAM1, E, N, H		
	EXE EXE EXE	
MOTHELLATH O1, O2, C		

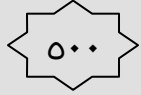

	EXE	
	EXE	
	EXE	
RSD, Z, ITIGAH		
	? EXE	
	EXE	
HADF EXE SHR EXE SHM EXE H EXE *** RAMI - TO = HADF EXE MESAFI = METER EXE ITIGAH = DARAGA EXE Z = MILS EXE		

1- NEW RAMI 2- NEW HADF 3- NEW RAMI& HADF 4- END 5- CORREC CHOOSE ?		
	5 EXE	
ZAWIA HDF – BOM		
	? EXE	
MASAFARSD- BOM		
	? EXE	
GANIBI = TAM DEGREE EXE ()		
RAASI = METER EXE		
MESAFARAME		

CHOOSE ?		
	1 EXE	
E, N, H RAMI		
	EXE EXE EXE	
HDF EXE SHR EXE SHM EXE H EXE RAN1 - TO - HDF MESAFA EXE ITIGAH EXE Z EXE		
CHOOSE ?		
	2 EXE	
	:	
Z, ITIGAH, MASAFA		
	? EXE ? EXE ? EXE	

MOTHALLATH O1, O2, C		
	? EXE ? EXE ? EXE	
RSD, Z, ITIGAH		
	? EXE	
HADF EXE SHR EXE SHM EXE H EXE RAMI TO HADF EXE MESAFI METER EXE ITIGAH DRAGA EXE Z MILS EXE		
1- NEW RAMI 2- NEW HADF 3- NEW RAMI & HADF 4- END 5- CORREC CHOOSE ?		
	3 EXE	
1RSD = 1 *** 2RSD = 2		

:

	RUN EXE	
1RSD = 1 *** 2RSD = 2 ?		
	1 EXE	
RASID E, N, H		
	EXE EXE EXE	
RAMI E, N, H		
	EXE EXE EXE	
RASD1, MESAFA, ITIGAH, Z		
RSD, Z, IGAH MOTHALATH O1, O2, C . :		
HADF SHR EXE SHM EXE H EXE RAM TO HADF MASAFA METER ITIGAH DARAGA Z MILS		

:

:

. () ()

(

(

() ()

(

. () ()













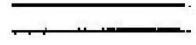
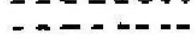

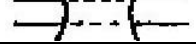

(

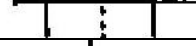

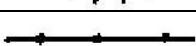
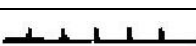

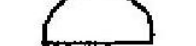







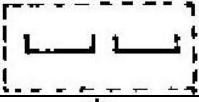





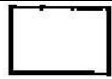

/













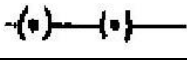
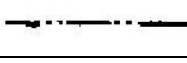
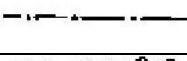

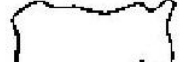
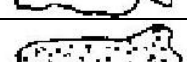
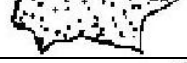
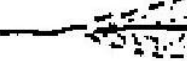
```

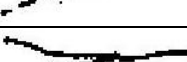
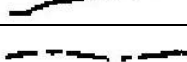
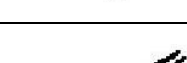
5   CLEAR
10  INPUT "1RSD = 1***2RSD = 2" ;GG
20  INPUT "RASID1, E, N, H";K2,K1,K5
30  INPUT "RAMI, E, N, H" ;K4,K3,K6
31  TT = 0: IF Q = 1 THEN GOTO 70
32  IF GG = 1 THEN GOTO 63
35  TT = 0: IF Q = 1 THEN GOTO 70
40  INPUT "MOTHALATH O1, O2 ,C" ;O,V,C
50  INPUT "RSD Z, ITTIGAH" ;Z1,U:TT = 0
60  T = 160-0-V:A = C*SINV/SINT
62  IF GG = 2 THEN GOTO 70
63  INPUT "Z, ITTIGAH, MASAFA" ;Z1,V,A
70  Q = 0 :N = K1+A*COSU :E = K2+A*SINU
73  IF N = K1 AND E = K2 THEN GOTO 240
75  IF N = K3 THEN GOTO 220
90  M = SQR((N-K3)^2+(E-K4)^2)
91  IF N = K3 THEN GOTO 100
92  S = ACS((N-K3)/M)
100 H = K5+(Z1*A/1000)
102 PRINT "HDF", "SHR" ;E;"SHM";N,"H";H
105 Z5 = 1000*(H-K6)/M
106 IF TT = 1 THEN GOTO 110
107 IF E<K4 THEN S = 360-S
110 PRINT "RAMI*TO-HDF ", "MASFA"; M, "ITIGAH"; S,"Z"; Z5; "MILS"
130 PRINT "1. NEW RAMI"
140 PRINT "2. NEW HDF"
150 PRINT "3. NEW RAMI &HDF"
160 PRINT "4. END"
161 PRINT "5. CORREC"
164 INPUT "CHOOSE ...."; I
165 IF I>5 OR I<1 THEN GOTO 130
170 ON 1 GOTO 180,190, 200,210,211
180 Q = 1:GOTO 30
190 GOTO 32
200 GOTO 1
210 END
211 GOTO 5
220 IF E<K4 THEN S = 270 ELSE S = 90
230 TT = 1: GOTO 90
240 PRINT "INTTIBAH ...!! RASID = HADA

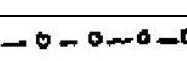



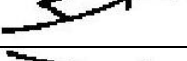





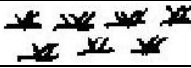
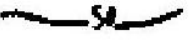
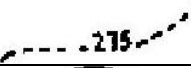

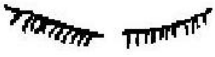
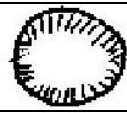
```

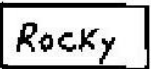
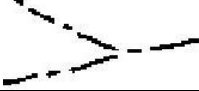
			
			
			
			
			
			
			
			
			
			
			
			
			
		()	
			
			
			
			
			
			
			

()

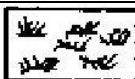
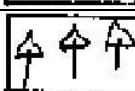
:

:

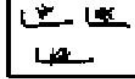
.

.

.

.

.()

.

.

()

)

(

▪

▪

)

- -

.(

.

:

(
(
(
(

:

.

:

-
-
-

:

:

.

.

-
-

()

(

(

(

(

)

.(

()

()

()

()

:

() .

.

.

.

.

:

)

.(

.

.

.

.

.

.

() .

.

()

()

(,)

):

.(()

: _____

:(Diamond Pick) ▪

.()

:(Small Diamond Pick) ▪

:(Tumbler Cylinder Pick) ▪

: ▪

Double Wafer Cylinder ▪

Tumbler Cylinder

. (,) (,) ▪

. (,) (,) ▪

. (,) ▪

. (,) ▪

(Rake Pick) :

Diamond Pick

(Ball Pick) :

()

(Double Ball pick) :

(Diamond Pick) :

(

.Pin Wafer

(Feather touch) () :

S.P.T - -

:

(

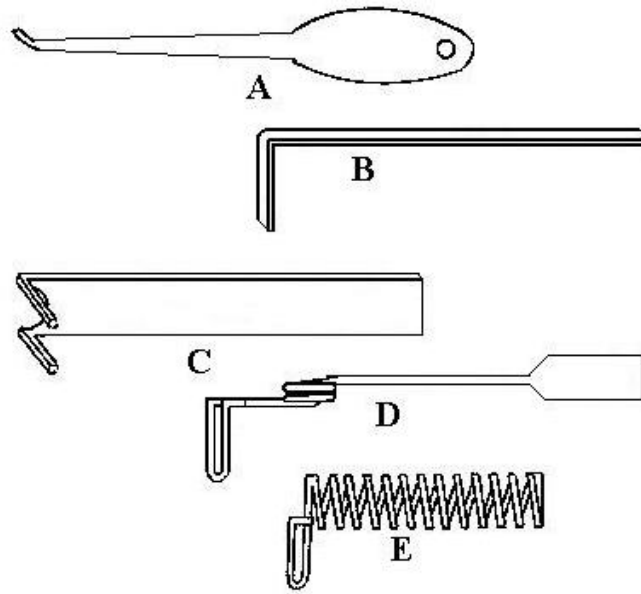

Figure 5. A) a hook pick; B) a pin and wafer lock tension wrench; C) a double-wafer tension wrench; D) a Feather Touch tension wrench; E) a homemade Feather Touch tension wrench.

()

()

-
-
-

:(P.T.L) Pin Tumbler Lock (

:(W.T.L) Wafer Tumbler Lock (

:(D.W.L) Double Wafer Lock (

:(W.L) Warded Locks (

:(L.L) Lever Locks (

:(T.C.L) Tumbler Cylinder Pick (

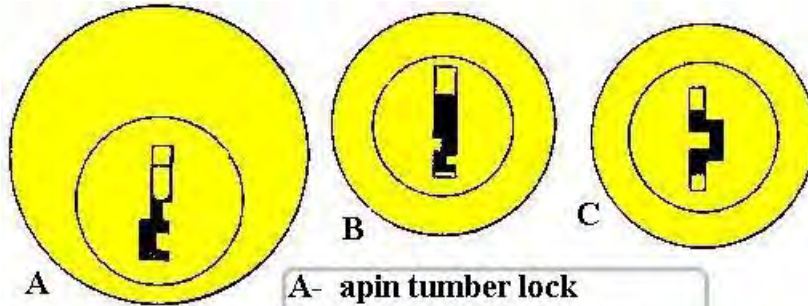

A- a pin tumber lock
 B- a wafer tumber lock
 C- a double wafer lock

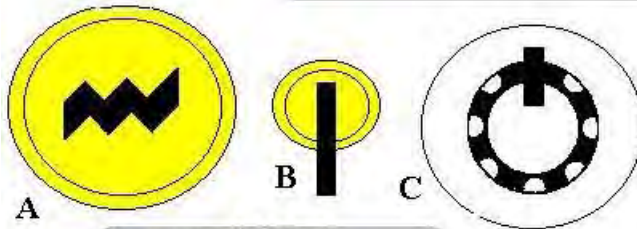

A- a warded lock
 B- a lever lock
 C- tubular cylinder lock

(P.T.L) (Pin Tumbler Lock) (

P.T.L

P.T.L

P.T.L

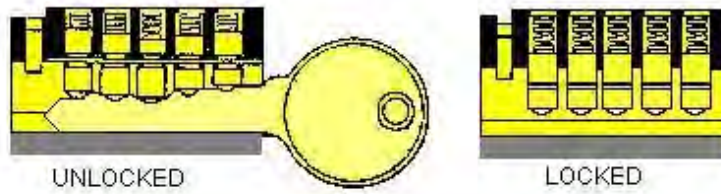

A pin tumbler lock

P.T.L

:

)

.(

(/)

▪

▪

▪

▪

▪

▪

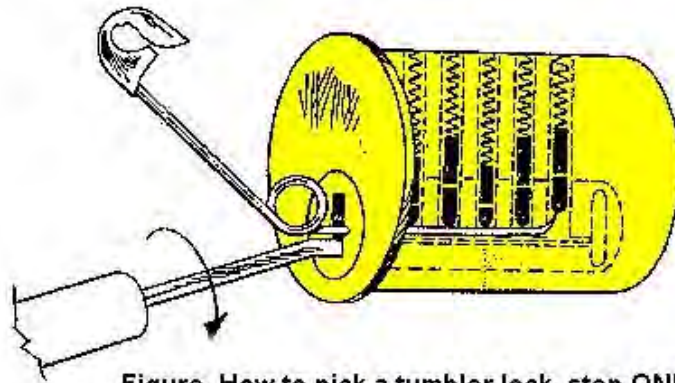

Figure How to pick a tumbler lock, step ONE

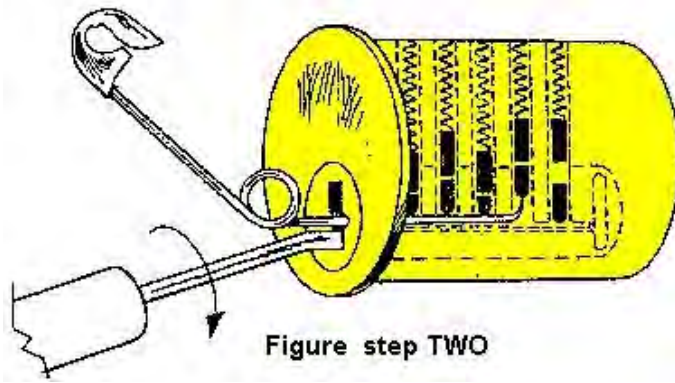

Figure step TWO

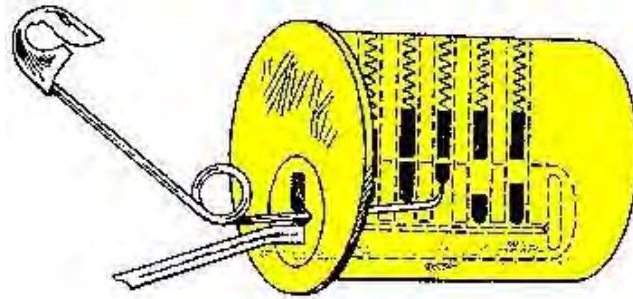
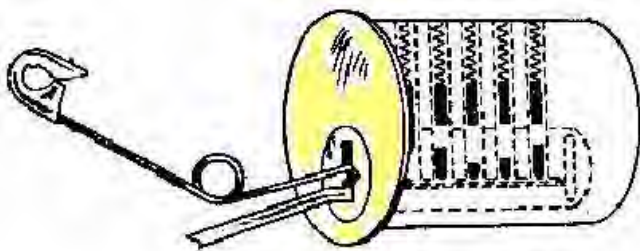
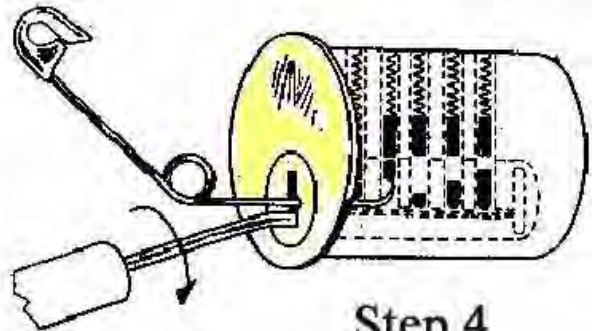

Figure step THREE



Step 5



Step 4

(W.T.L) (Wafer Tumbler Lock)

(

P.T.L

(%)

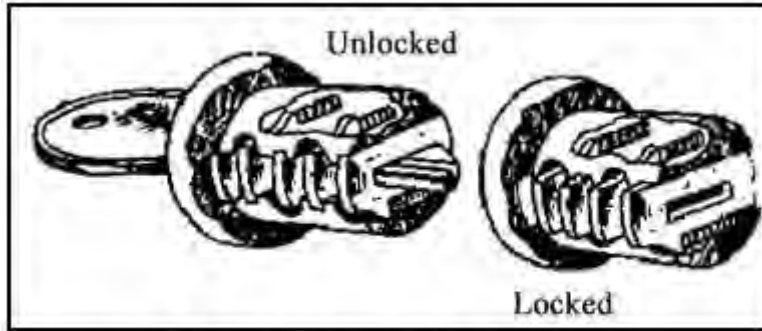

A wafer-tumbler lock

P.T.L

P.T.L

W.T.L

W.T.L

W.T.L

W.T.L

.P.T.L

W.T.L

:

-
-
-

L

GMC

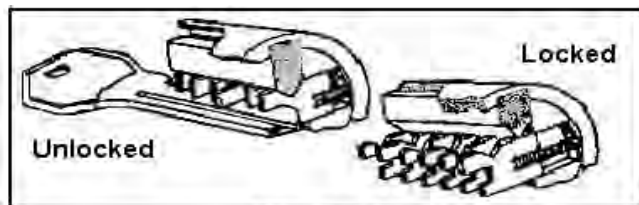

Side bar lock

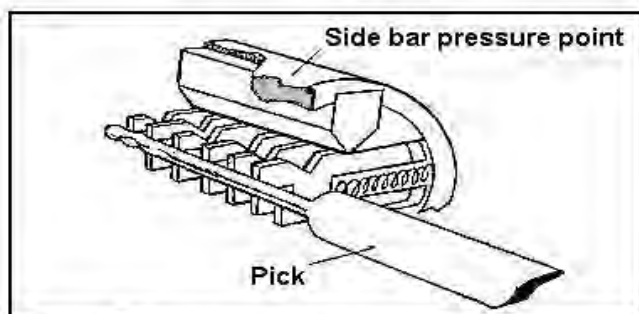

Figure The rake pick inserted in the side bar lock

.P.T.L

()

(P.T.L)

(P.T.L)

(P.T.L)

(P.T.L)

(D.W.L) (Double Wafer Lock) (

S.W.L

Ball Pick

() D.P

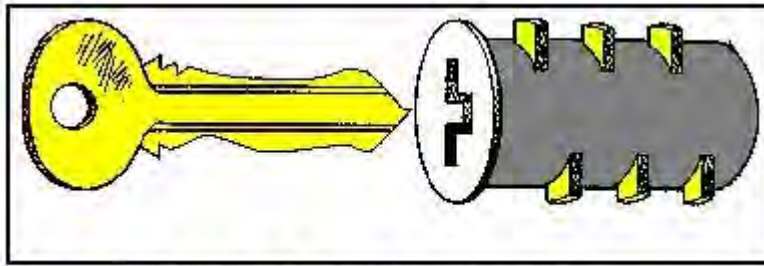

Figure A double-wafer lock

()
 .(P.T.L)

()

)

(D.W.L)

.(

(D.W.L)

(W) (P.T.L)

D.W

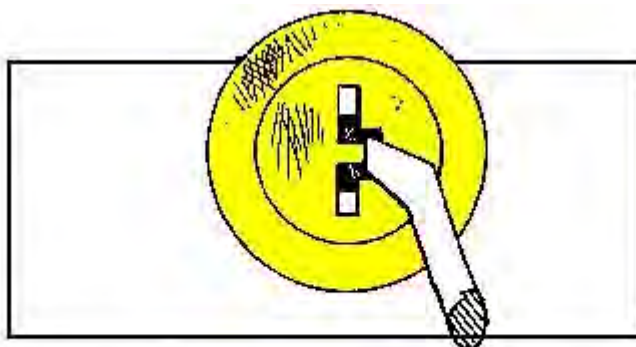

Figure Inserting a tension wrench in a double-wafer lock

(Pin and Wafer Tumbler Pad Lock)

(

()

(Warded and Lever Locks)

(

Pin and W.T.L

W.L

W.P.L

W.P

() W.P

W.P

T L

T

L

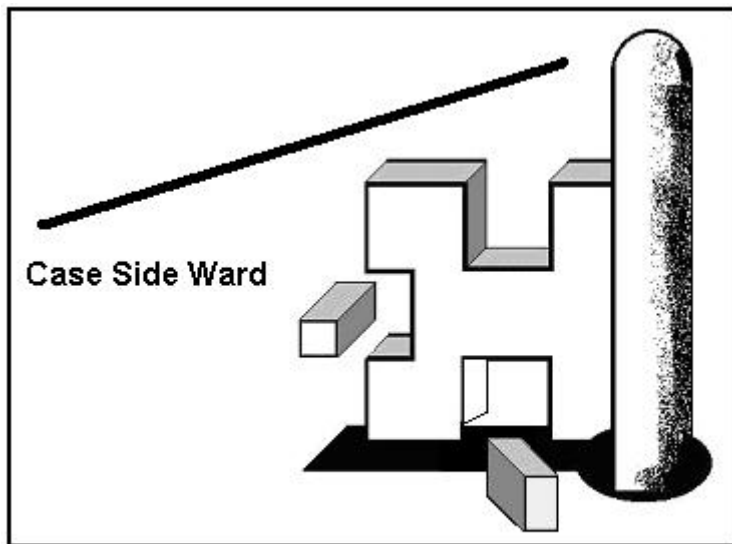

A warded lock

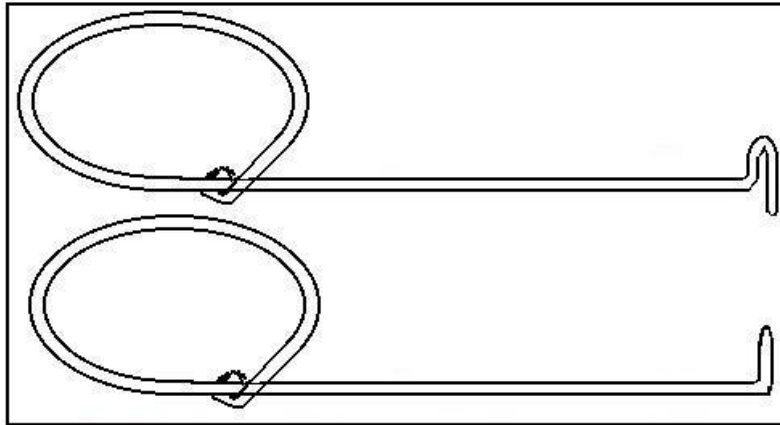

The T-shaped pick (top) and the I-shaped pick (above)

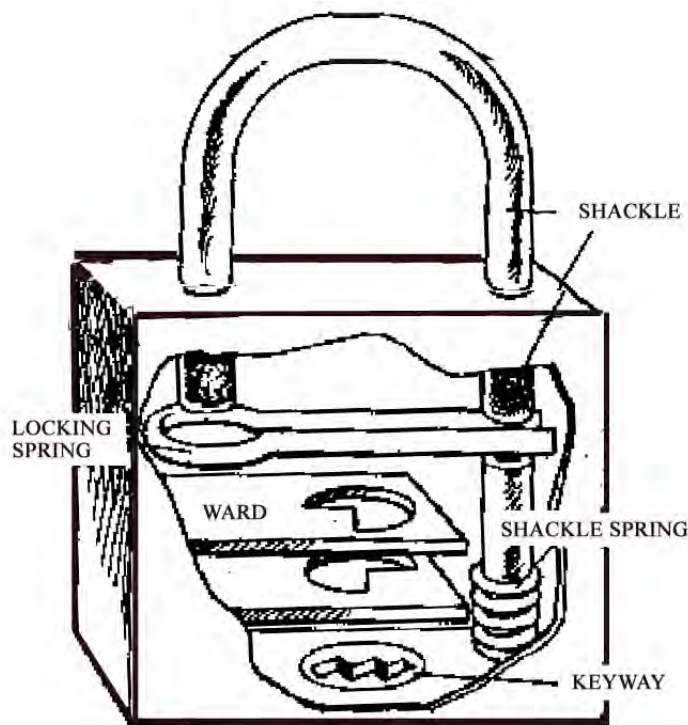

W.P

(,)

W.P

W.P

.W.P

Level P

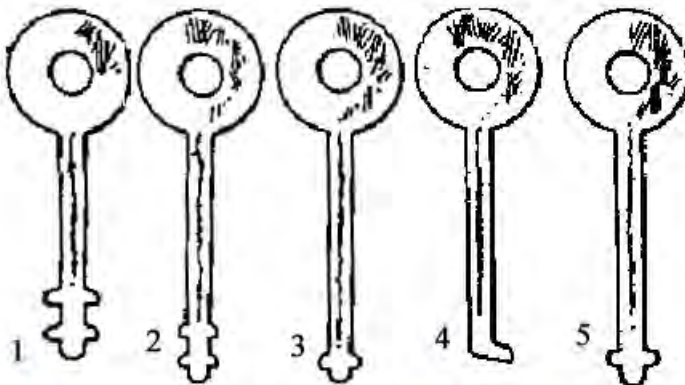

Of the Five Magic Keks

- 1 ... Large Double Spring
- 2 ... Small Double Spring
- 3 ... Small Single Spring
- 4 ... Lever Lock Key
- 5 ... Large Single Spring

W.P

Lever Lock

()

Lever

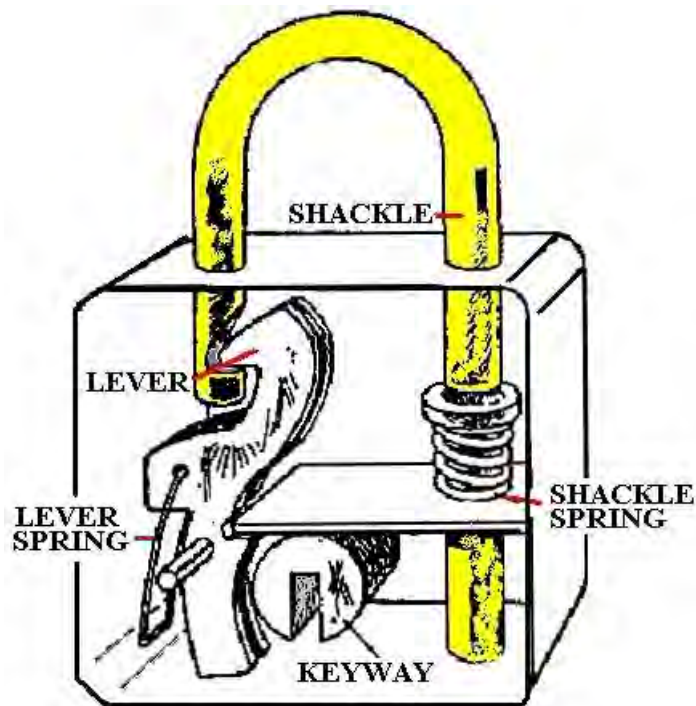

A simple lever PadLock

Lover

!!

()

L

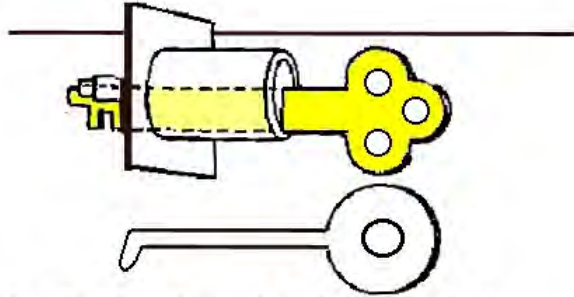

At the Top is a lever key in its keyhole.
Use the lever lock Magic Key (above)
to pick the lever-lock

▪
▪▪
▪
▪
▪

Tubular Cylinder Lock

(

:

(Tubular C)

P.T

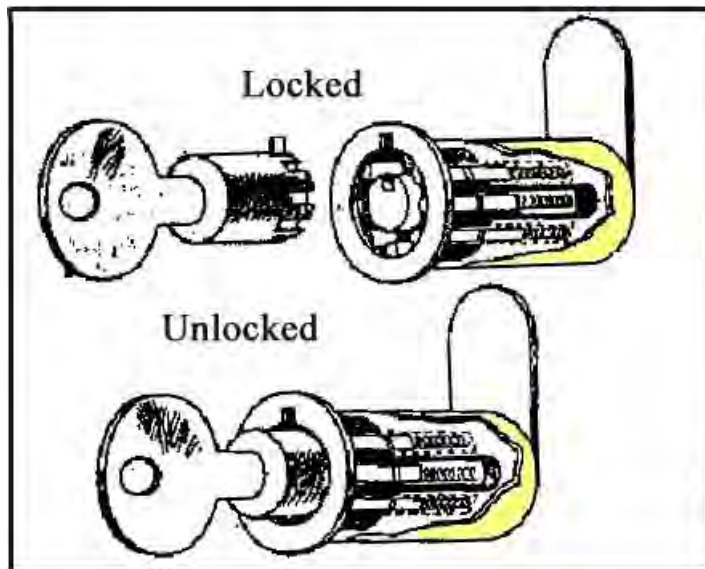

The Tubular cylinder locked (top) and unlocked (above)

()

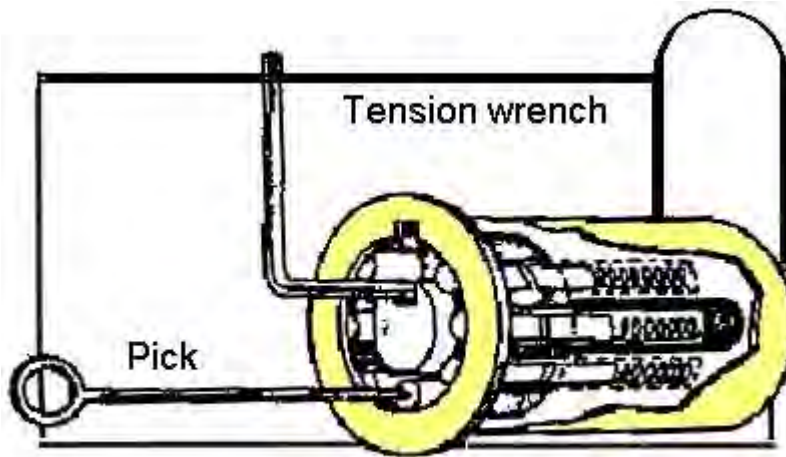

Picking a tubular cylinder lock

()

!!

()

Mashroom and Spool Pin Tumbler Locks (

Pin-Tum

M.S.Pin.Tum

Pad Lock



The spool pin is at left, and the
mushroom pin is at right

Magnetic Locks

(

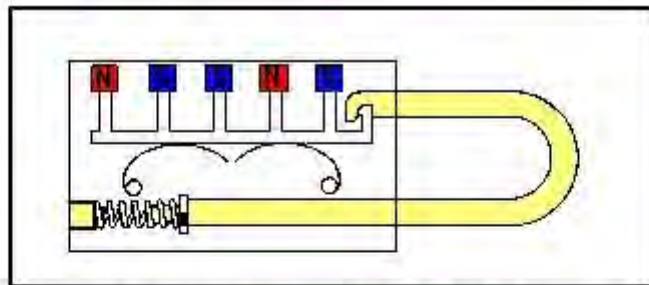

The Inner mechanism of magnetic lock is rather simple.

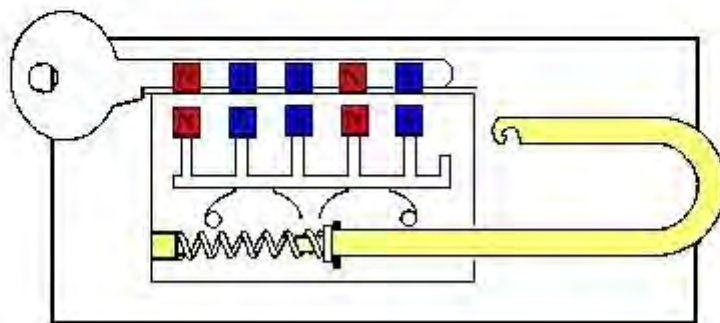

The Magnetic Key has the same Sequence of magnets as the lock.

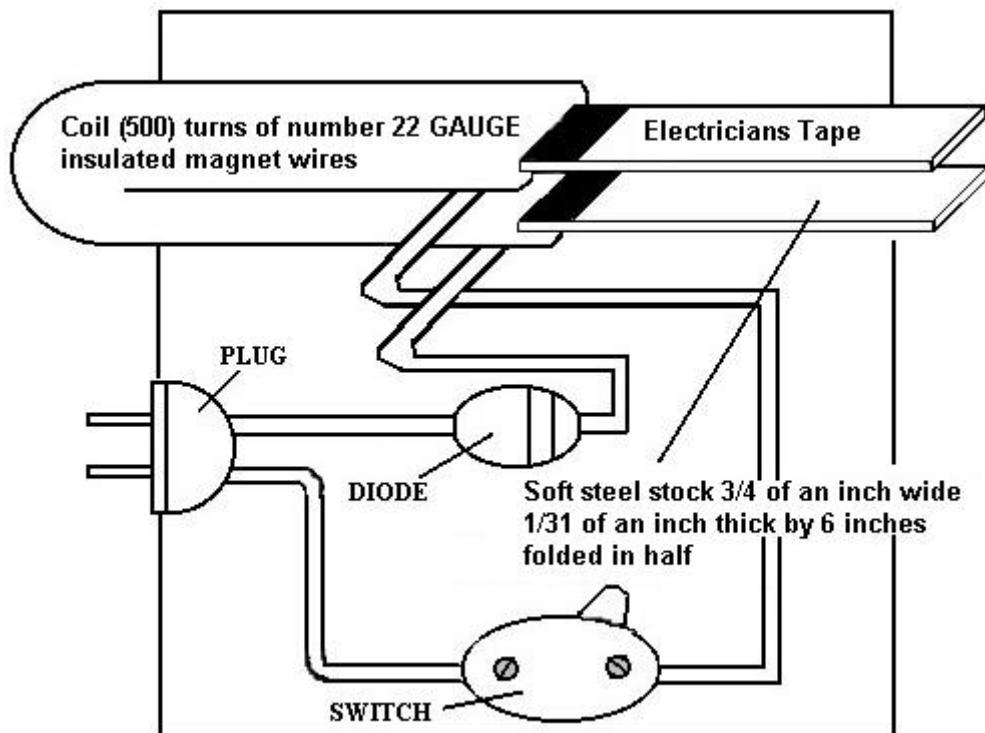

()

()

()

Disk Tumbler Locks (

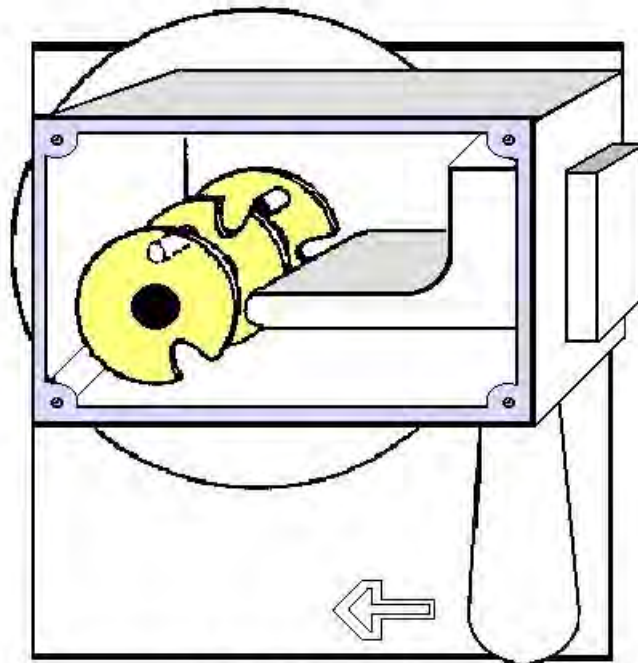

A disk tumbler lock

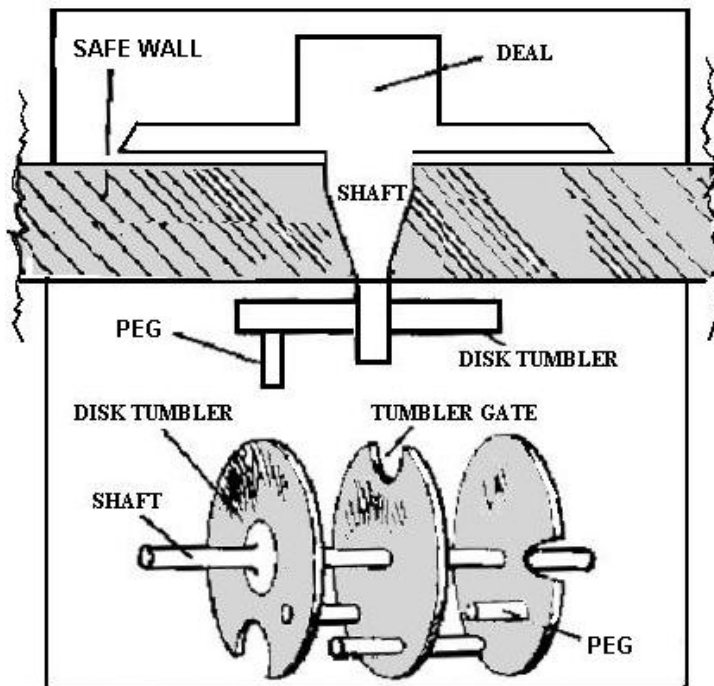

Here is a modern disk tumber dial system (top), and a set of disk tumblers (above)

() .

()

(Master, C, Pad) : ()

() .

()

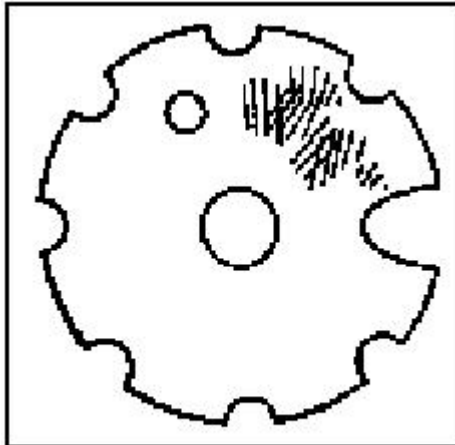

A modern disk tumbler

(

)

()

()

()

▪

▪

▪

▪

▪

▪

▪

▪

▪

▪

.()

▪

()

▪

▪

▪

▪

▪

▪

.()

▪

()

▪

()

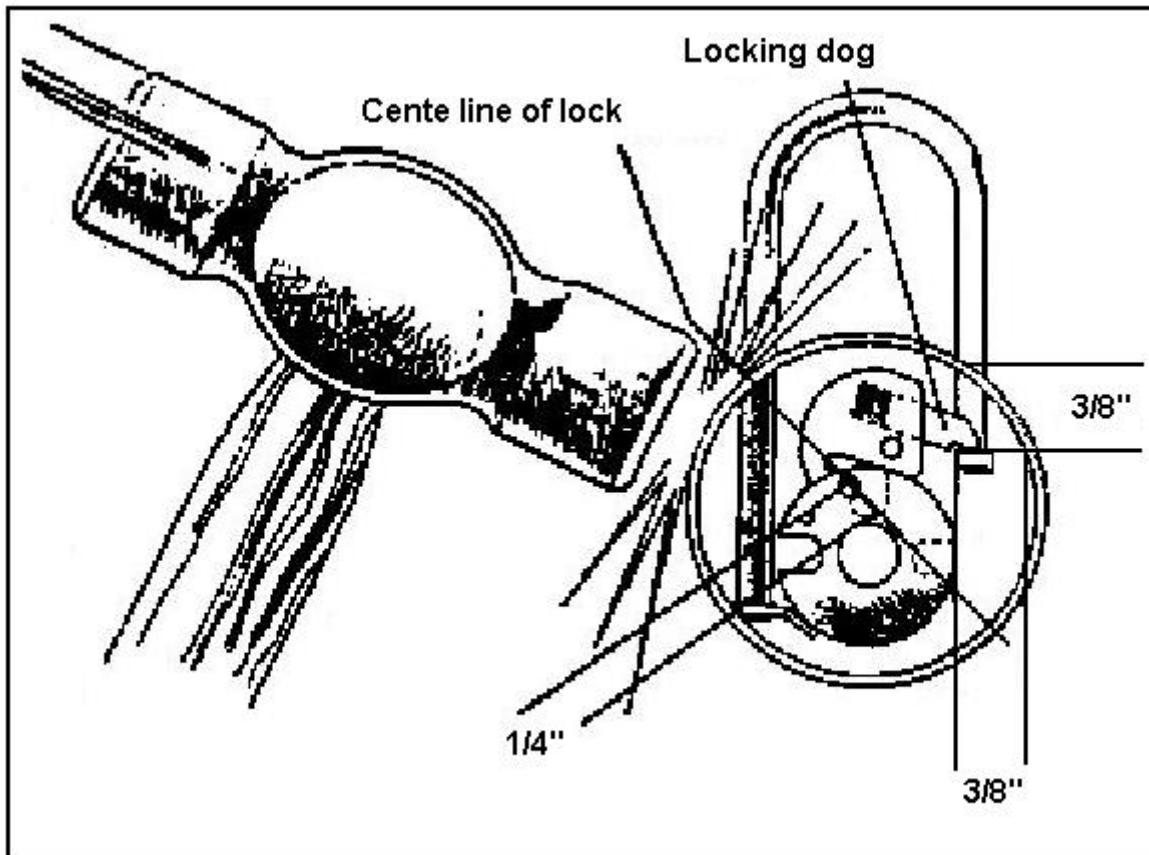

The simplest technique for opening combination locks

▪

▪

▪

▪

▪

.

▪

▪

()

.Medeco
(Lock Smith)

▪

▪

▪

()

.

:

()

- -

.

.

)

(

.

.()

_____)

_____)

-

(Communistes Cellues Combatants) (C.C.C)

.()

() ()

() ()

.

.

.

()

)

(

:

(

() (

()

.()

)

()

.(

()

()

()

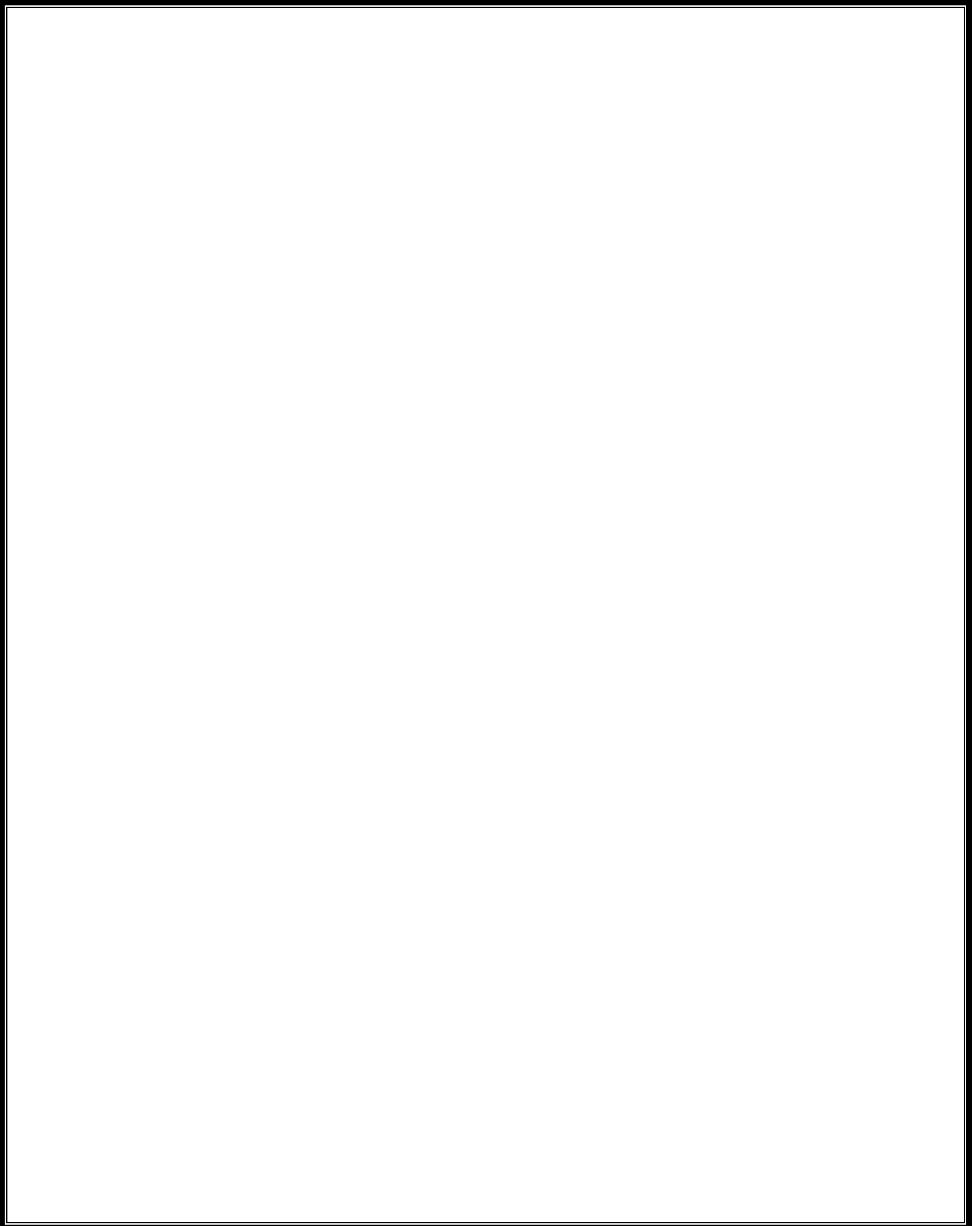

()

()

٠ () :

()

()

:

(

(

(

(

.

(

(

(

(

)

.(

(

(

(

.

▪

▪

)

()

(

:

()

()

.()

()

:

:

:

(

(

(

()

(

()

:

(

(

()

(

(

.

:

: (

()

.()

: (

)

.() () (

:

-
-
-
-

()

()

-
-
-

:

(

:

(

.%

:

(

.

(

.

(

.()

(

(

.%

:

(

.

(

.%

:

()

▪

.

-

-

▪

.

▪

.

▪

()

▪

.

▪

.

▪

:

▪

▪

▪

:

▪

▪

)

(

▪

()

()

:

▪ () .
▪ () .

)

.(

:

:

.

()

()

()

▪

▪

▪
▪
▪

)

.(

(

)

(

.(

(

(



:

.

.

.

()

()

.

.

.

.

.

.

)

.(

() .(

.

:

)

.(

▪

▪

▪

▪

. (:) .

()

) ()

(

()

()

()

(C.I.A)

()

)

(...

)

()

(

//

.()

()

()

:

(()) (

(()) (

:

.

.

:

:

:

)

()

(

:

()

:

:

▪

.

:

▪

.

:

▪

.

:

:

▪

:

.

.

:()

▪

.

.

.

:

)

()

:

▪

.() () :

(

▪

:

:

(-) .

(

(

(

(

(

(

:

()

()

...

.

(...

)

.

.

.

.

()

.....

:()

-
-
-
-

.)

...

.

...

.

.

:

.

.

:

■

.

:

■

.

■

.

()

()

()

()

.(-)

)
//

.(-

()

()

.()

/

. //

.

//

.

//

()

(

.

()

.

.

()

()

. //

()

()

()

.

()

()

)

(

)

(

)

(

):

.

.

()

(

()

.

.

.

:

.

.

()

...

.

.

.

()

.()

.

:

.

.

.

() ()
(B.C.R.A) ()
(D.G.E.R) ()
(S.D.E.C.E) ()
()
() (Intelligence Service)
() C.I.A
() F.B.I
() ():

()

() ...

()

:

(
(
(
(
(

.

.

:

() ()

()

:

:

.

:

()

:

.

)

(

() () ()

()

:

:

:

() ()

:

()

(Atam)

.()

:

()

()

:

()

.

()

:(

)

)

()

()

(

(

)

()

.

()

()

() .

_____ :

() :

()

()

:

)

(

()

)

.(

(-)

(-)

()

()

:

)

:

()

()

(

()

()

⋮

:()

)

(()

()

. ()

:()

()

-

:

()

.()

:

.()

()

-

-

.

)

.(

()

()

.

.

.

.

)

() (

.

.

.

//

.

.

:

.

.

.

.

()

)
)

()

(

.(

()

:

.()

▪

.()

▪

()

()

()

()

()

()

()

() .

()

()

()

()

()

()

()

()

()

()

()

▪ ()

▪ ()

▪ ()

▪ ()

▪ ()

()

)

(

()

%

...

” :

”

()

()

()

()

()

()

()

()

()

()

()

()

()

()

()

)

(

()

()

()

()

":

."

":

."

()

()

()

()

()

"		"			
	..				
	..				
	()				
	..				
	..				
	()				
	.. " "				
	..				

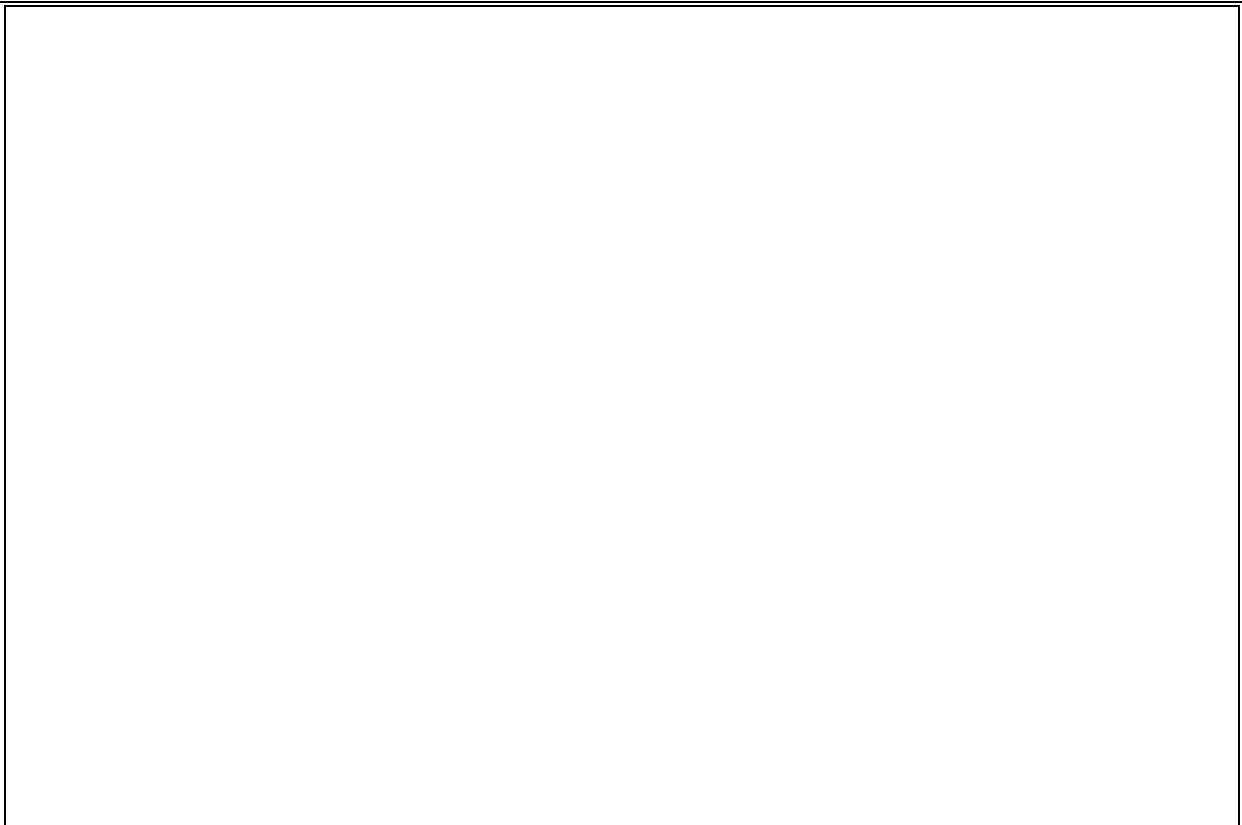

-

:

(

(

(

(

(

.

.

.

.

.

(
(
(
(

:

-
- △
-
- ★
- ✕
- ⊙
- ⊗
- ①
- ②
- ☎

" (KATSA) "

(. .) (. .)

:

" ") (

.(

(

(

(

(

(

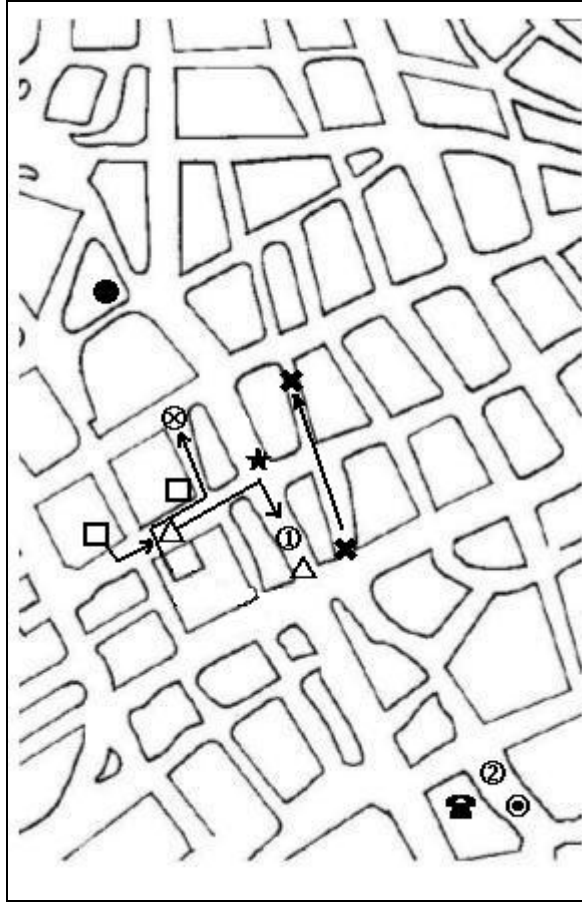

) " "

" " (

.(

.()

" " (

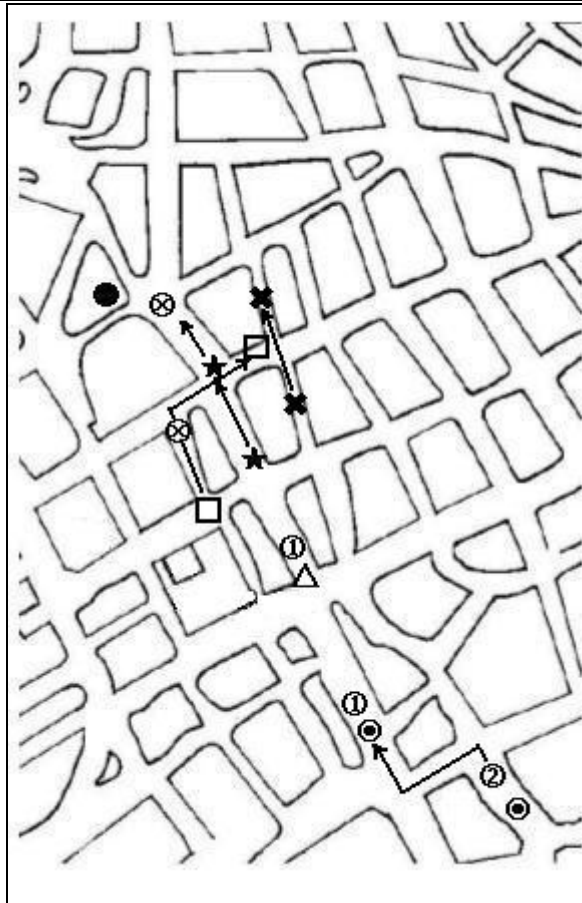

" " (

" " (

" " (

" " (

" " (

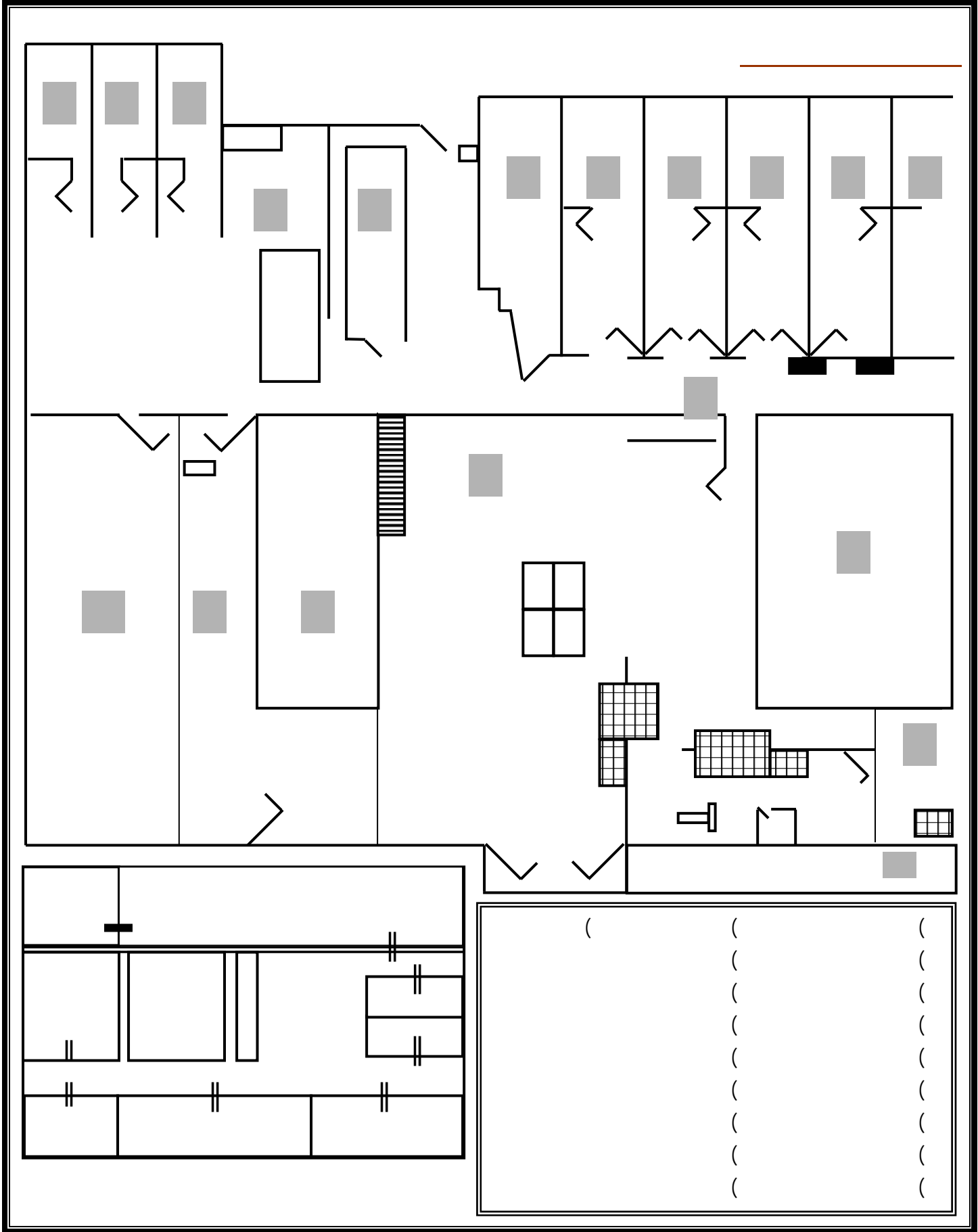

()

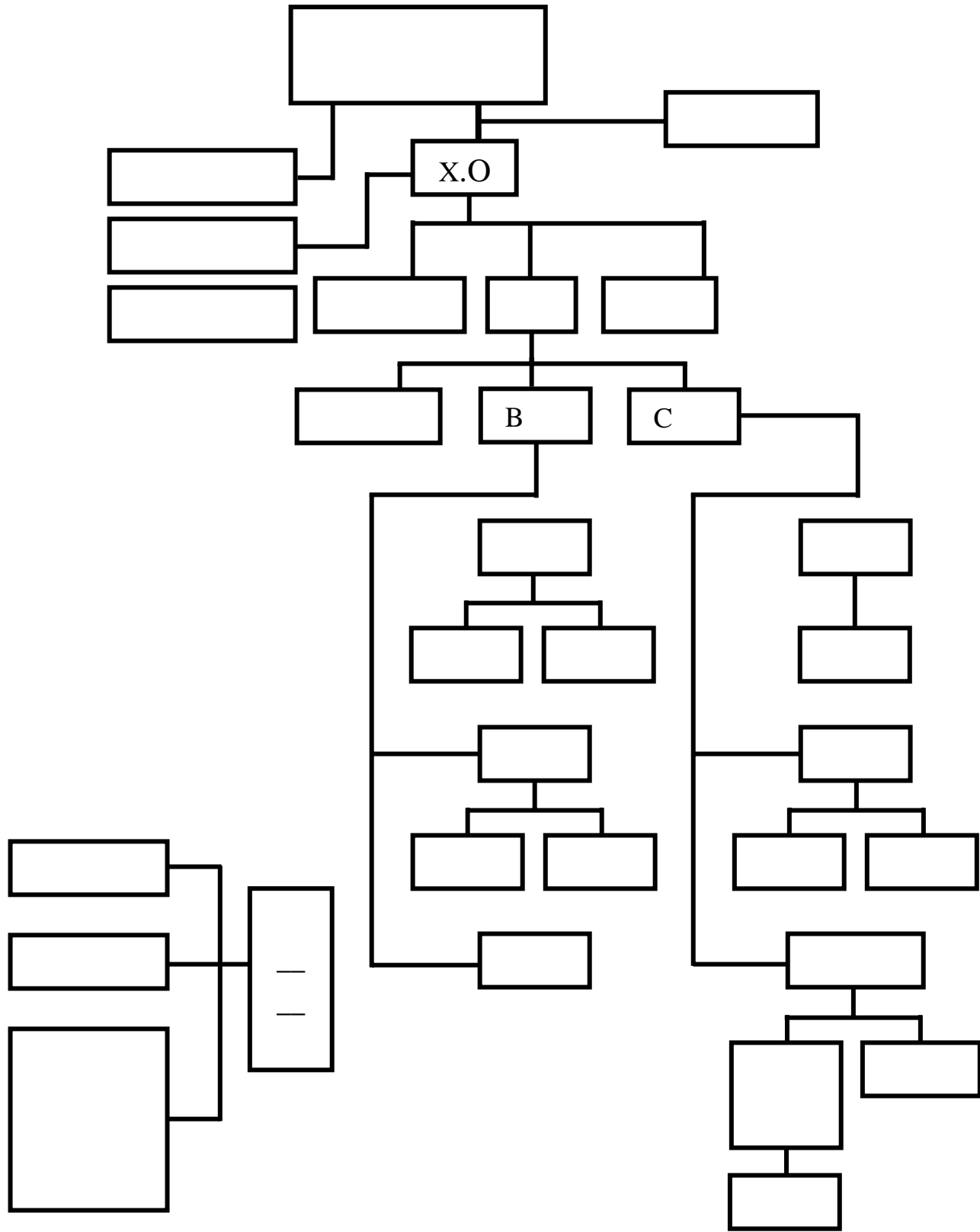

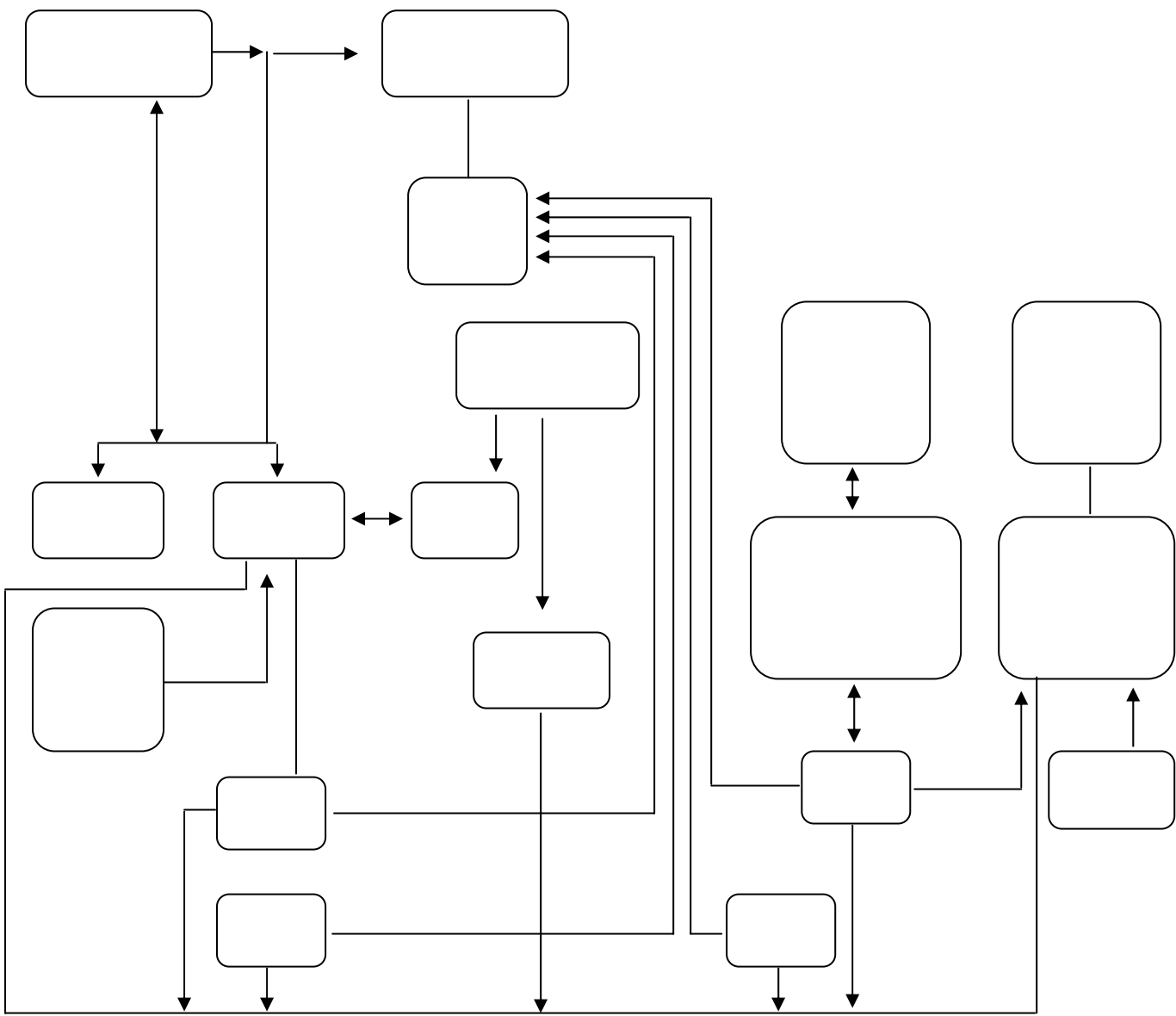

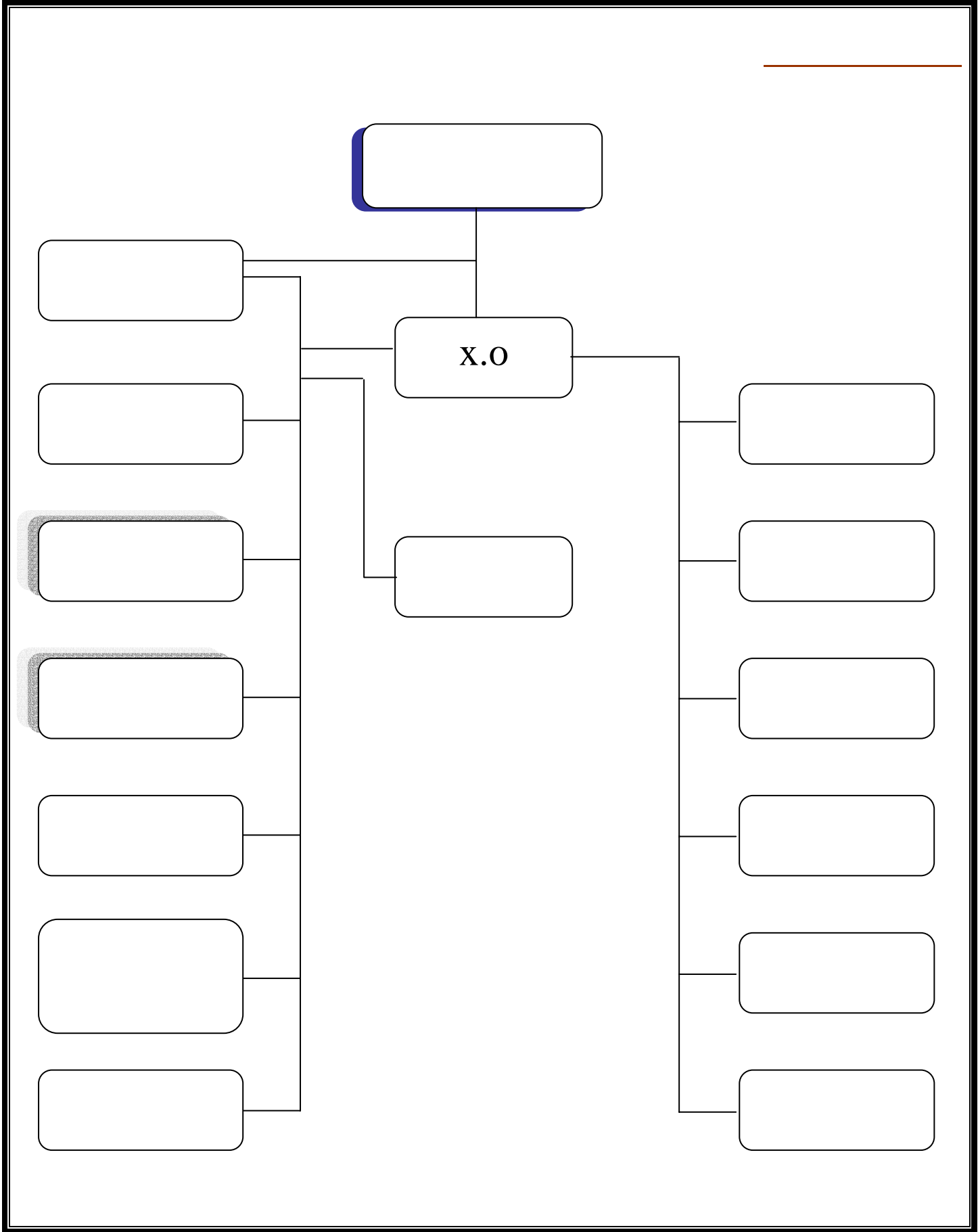

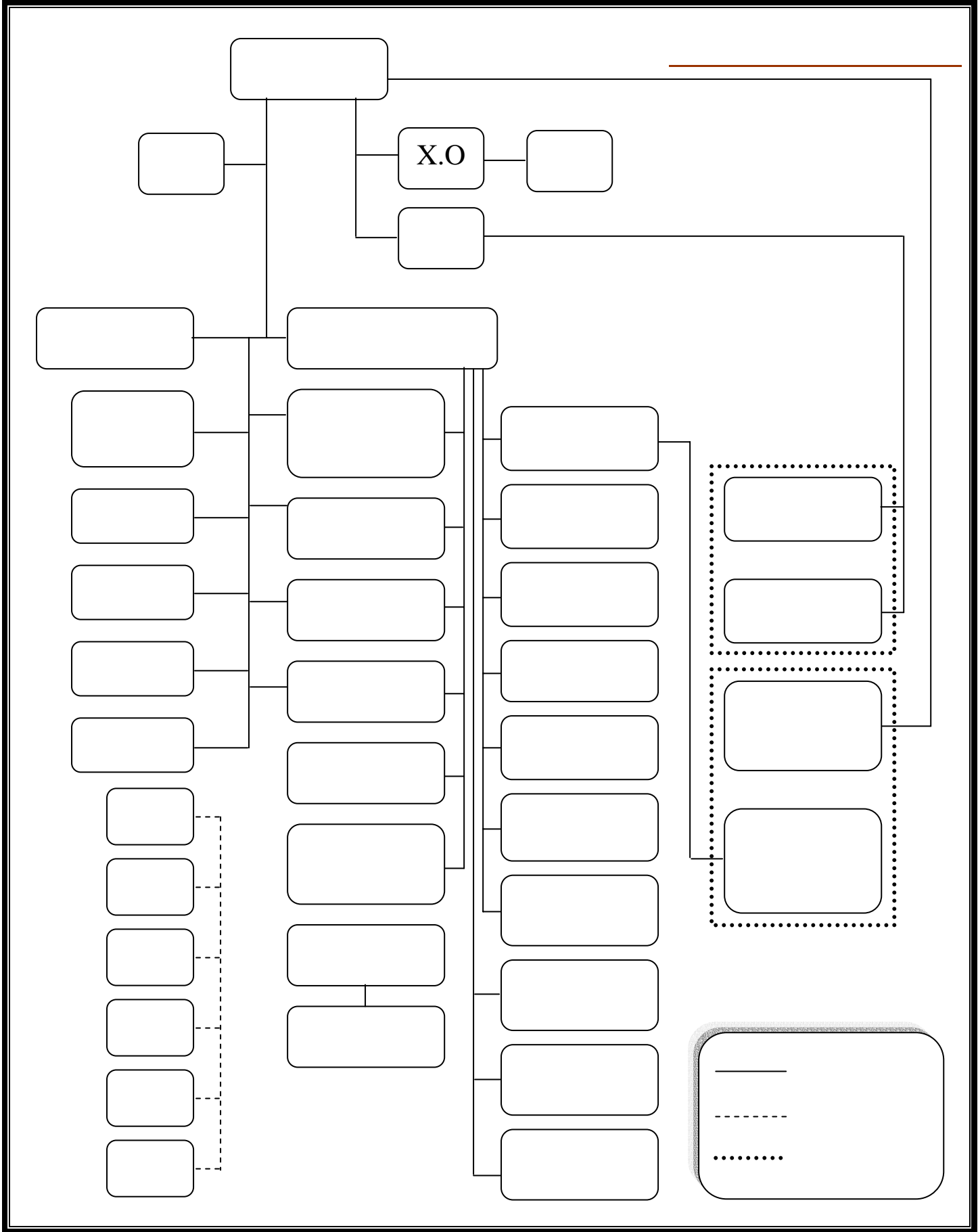

() .

()

()

() .

:

-
-
-
-
-

:

..

()

:

(:)

(:)

:

... .

(:)

:

(:)

:

()

()

(Sabotage)

()

()

(Sabots)

()

()

(Fifth Column)

()

()

()

()

()

()

()

:

:

(Intelligence)

(Espionage)

()

()

)

.(

()

(

(

:

%

:

:

-

(

(

(

.()

:

()

(Ping Fa)

(Sun Tzu)

:
) ()
() () ()
()
() ()
()
() ()
() ()
() ()
() ()

()

(Dreyfus Affair)

(-)

(O.S.S)

()

(M1-6 -) (M1-5 -) (CIA)
(SDECE) (G.P.OU . .) (KGB . .)
(SHIN BET)

() ()
()

()

“

”

:

-
-
-
-
-
-

.())

.(

()

.() -

(-) (-) ()

"

" :

()

()

()

()

)

.(

%

()

()

()

)

()

()

:

()

)

.(

()

.()

:

(

(

(

(

(

(

(

....

{هنا يوجد صفحة ناقصة}

....

▪

▪

▪

▪

▪

▪

▪

▪

:

:

.

:

.

:

.

.

:

■

.

:

■

.

:

▪

▪

▪

()

:

▪

:

:

▪

.

▪

.

:

▪

:

.

:

.()

:

▪

▪

:

▪

.()

:

▪

:

▪

:

(

:

.

.

.

.

.

.

:

.

.(

)

.

.

.

(

(

)

.

.

(

:

▪

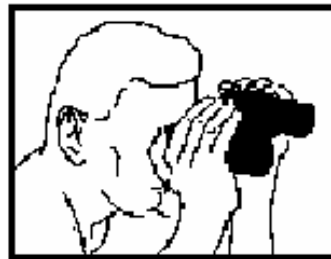
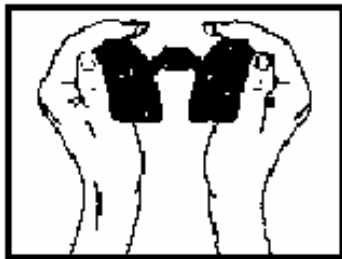

▪

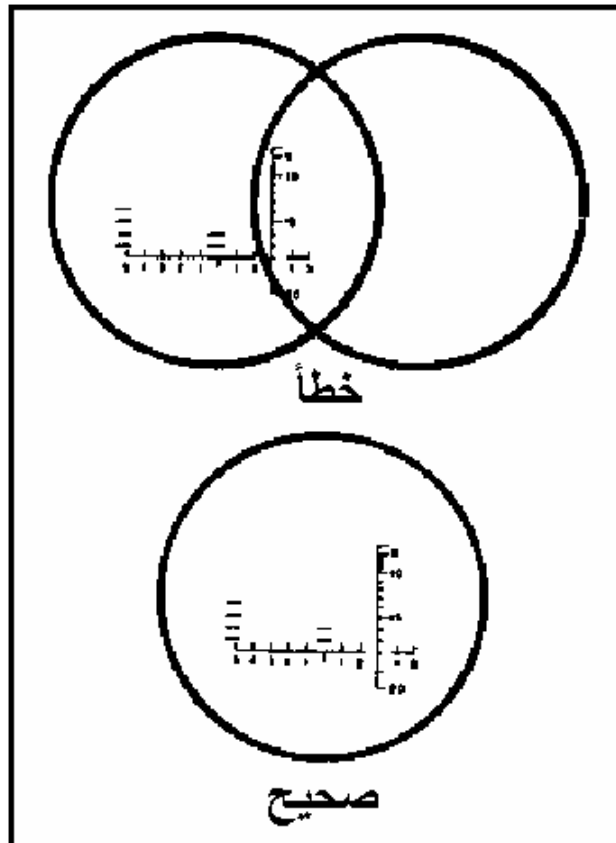

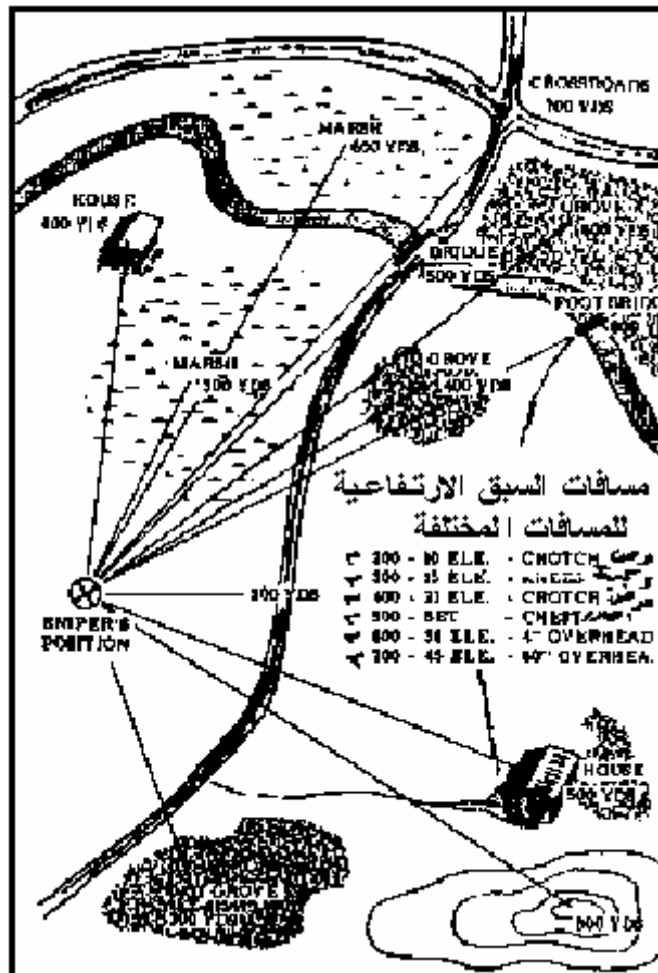

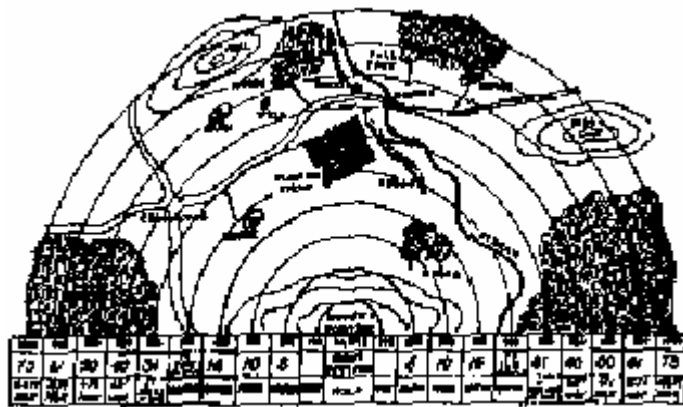
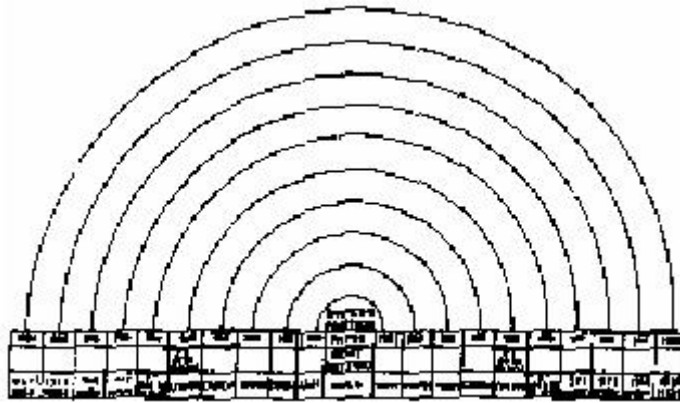

()

(

()

▪

▪

▪

▪

:

:

(

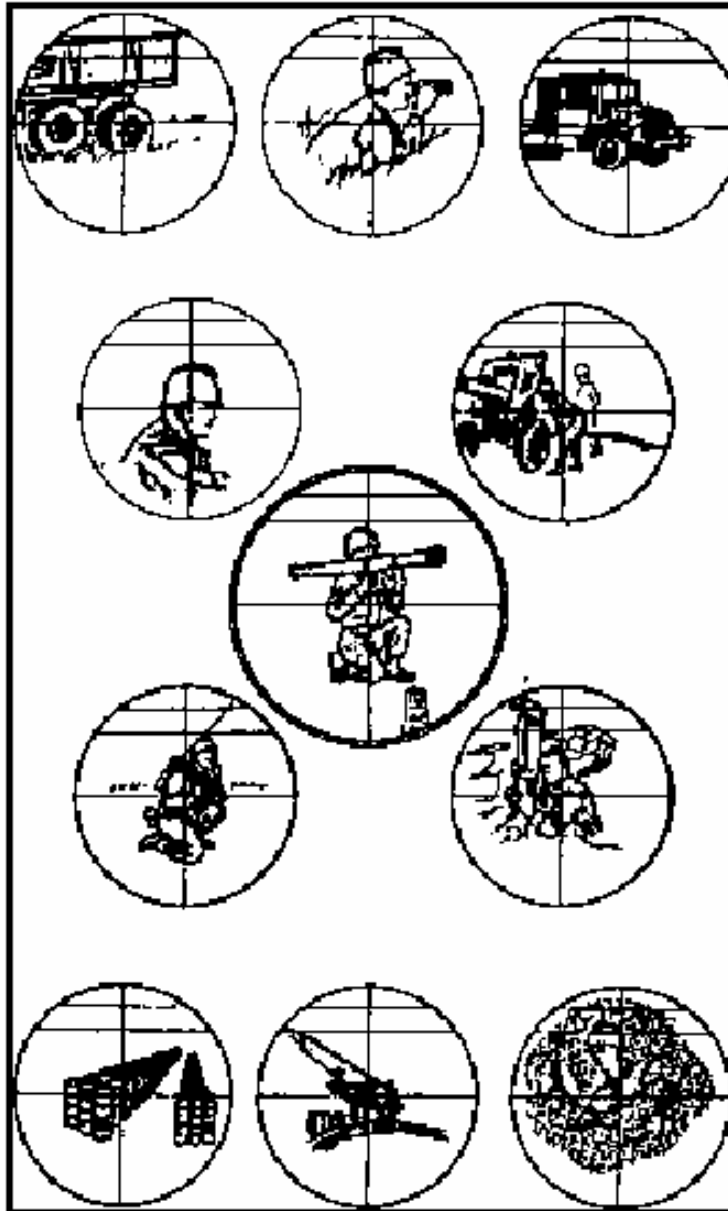

(

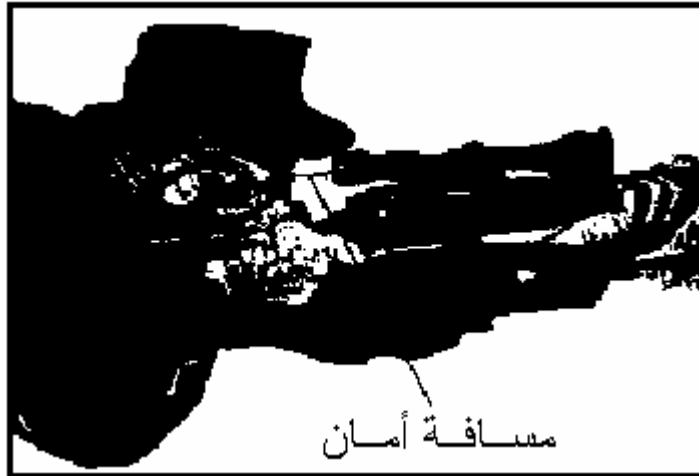

(

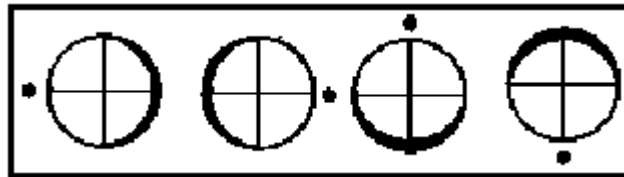

(

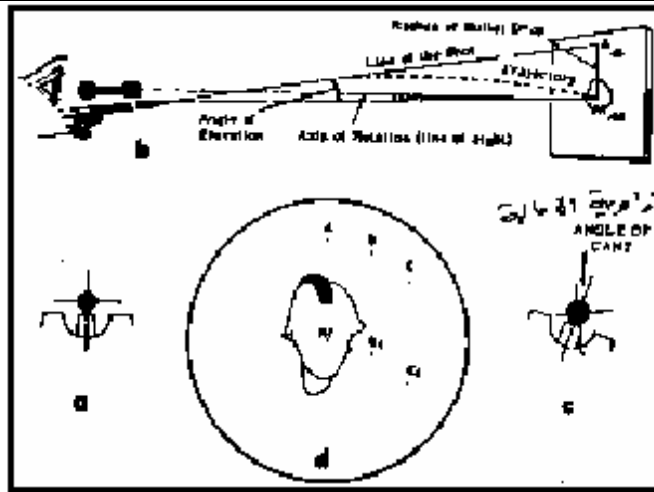

B1 C1





(

(

(

(

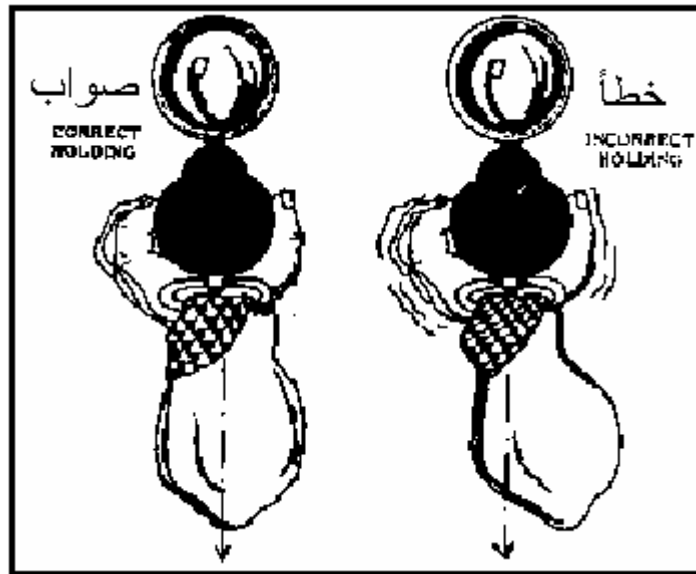



(: .



(: .

(: .

(:

:

(

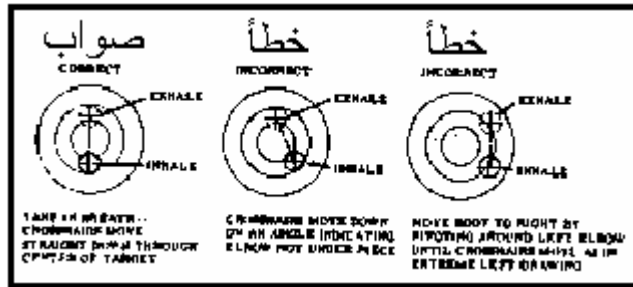

(

:

(

:

(

(

(

:

(

:

(

(

=

= ÷

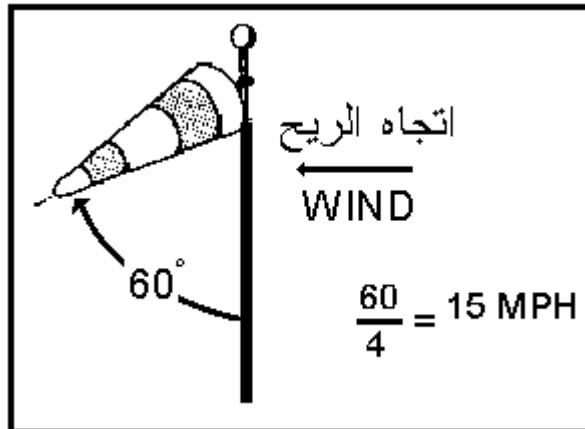

(



(

(

(

(

(

(

:()

(

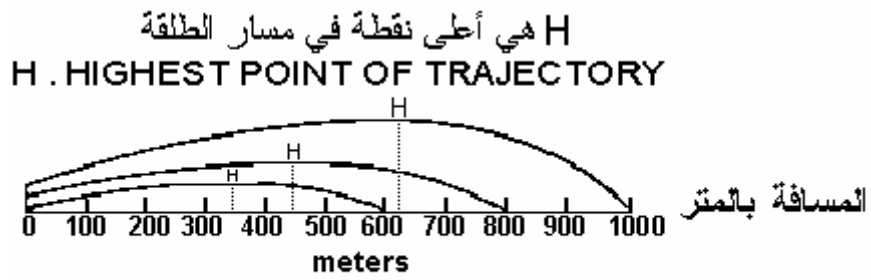

مسار الطلقة على مسافات مختلفة

:

(

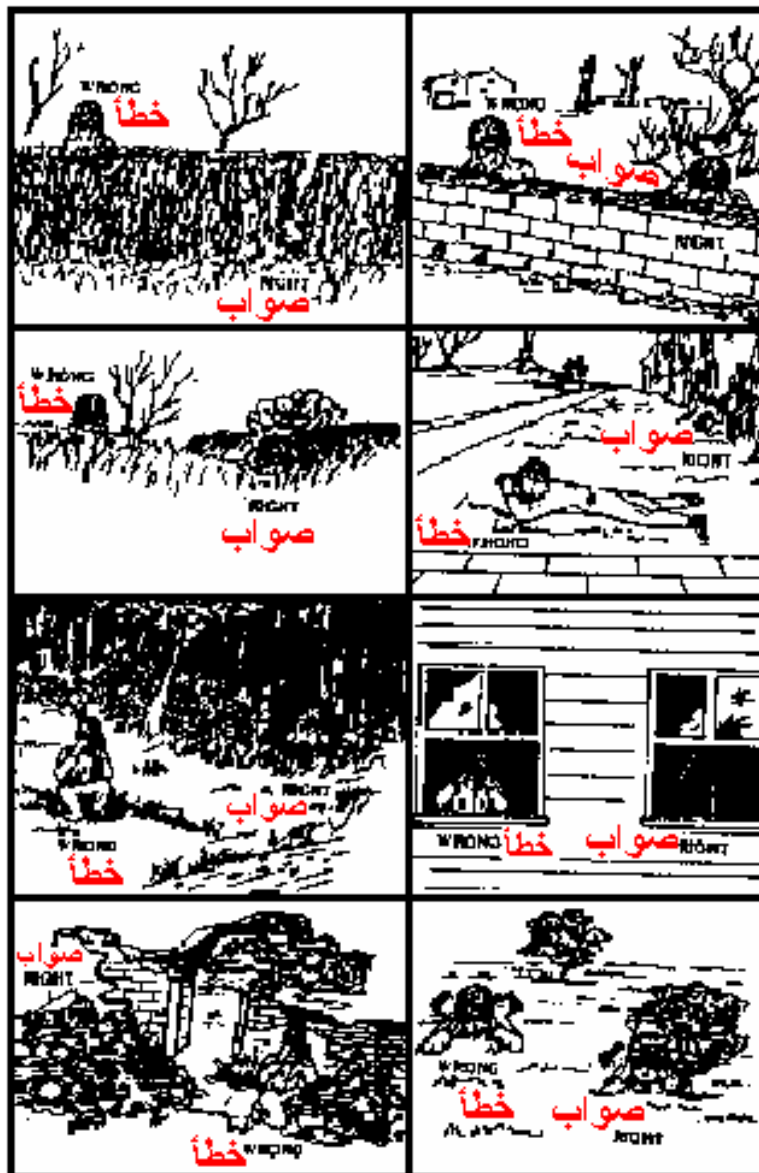

(

(

(

(

(

()

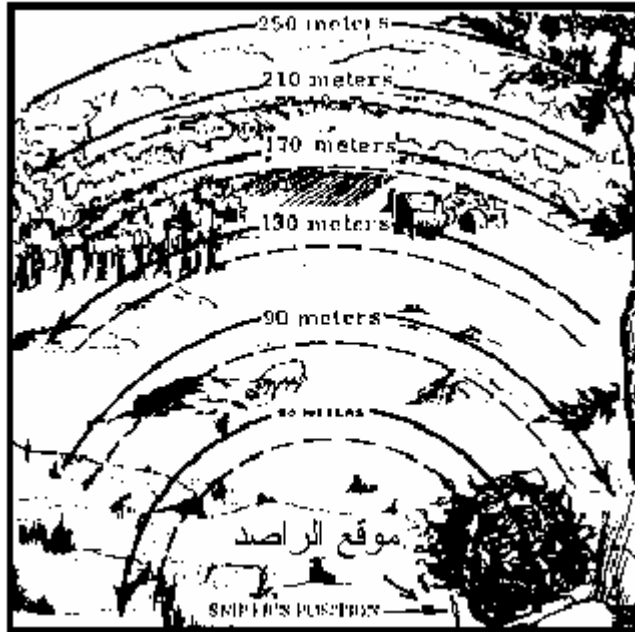

(

:

:

(

:

()

(

(

(

(

:

(

:

:

(

(

(

(

:

()

(

(

(

(

(

(

(

(

(

:

:

(

:

(

:

(

(

(

(

(

:

()

:

(

:

(

(: .

:

:

(
(
(
(
(
(
(
(

:

(
(
(
(
(

(

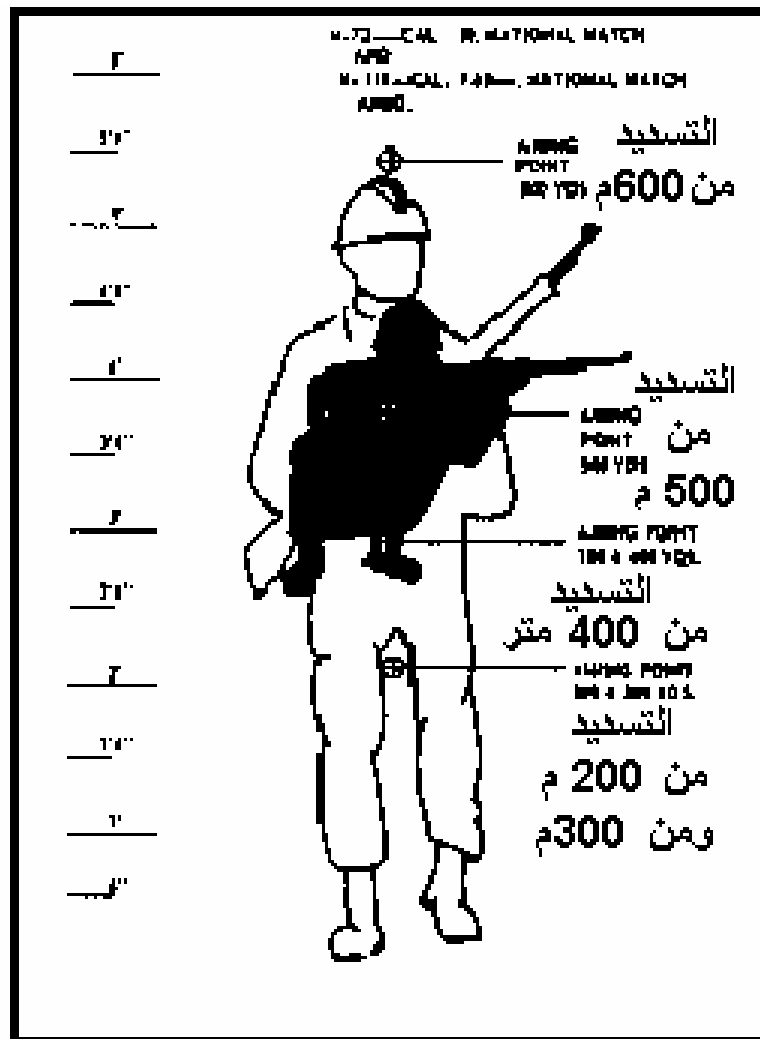

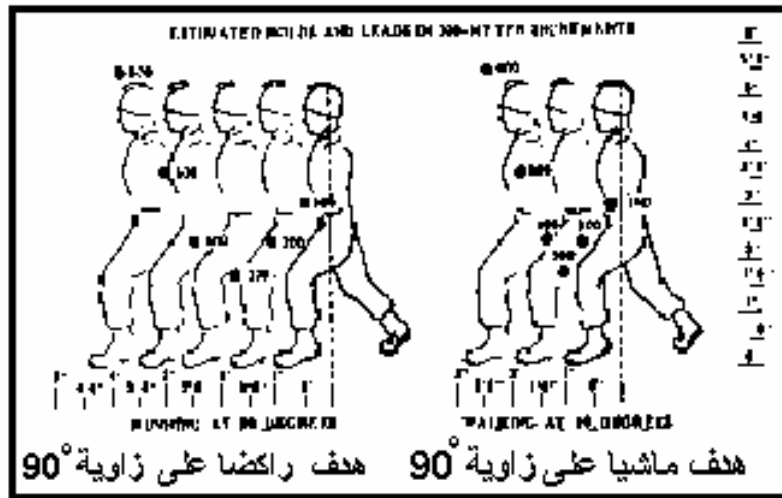

() ()

(

:

: (

: (

: (

(

(

...

(

:



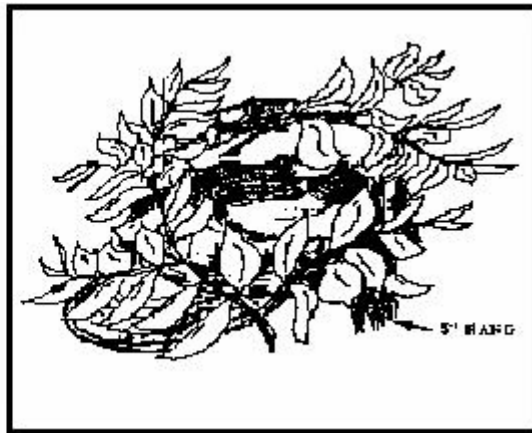
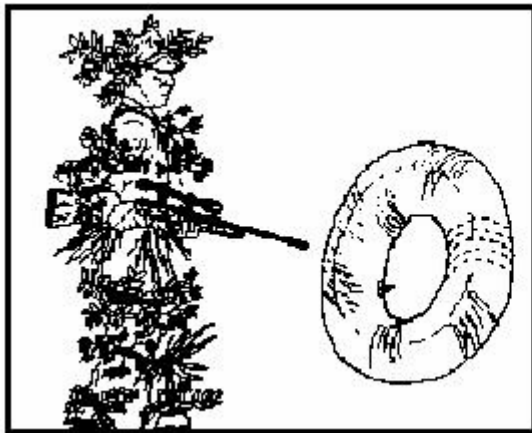

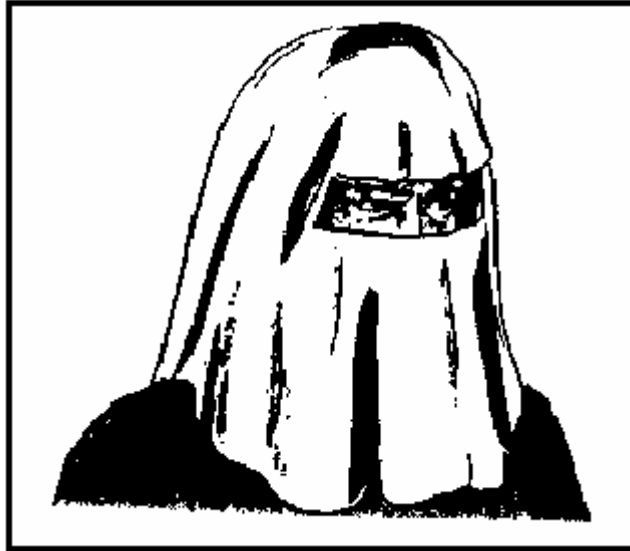

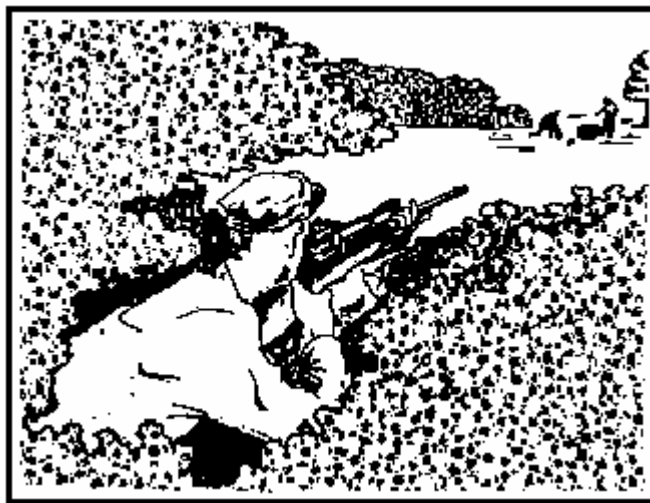

:

.

.

(

:

.

.

▪

▪

:

▪

.

▪

.

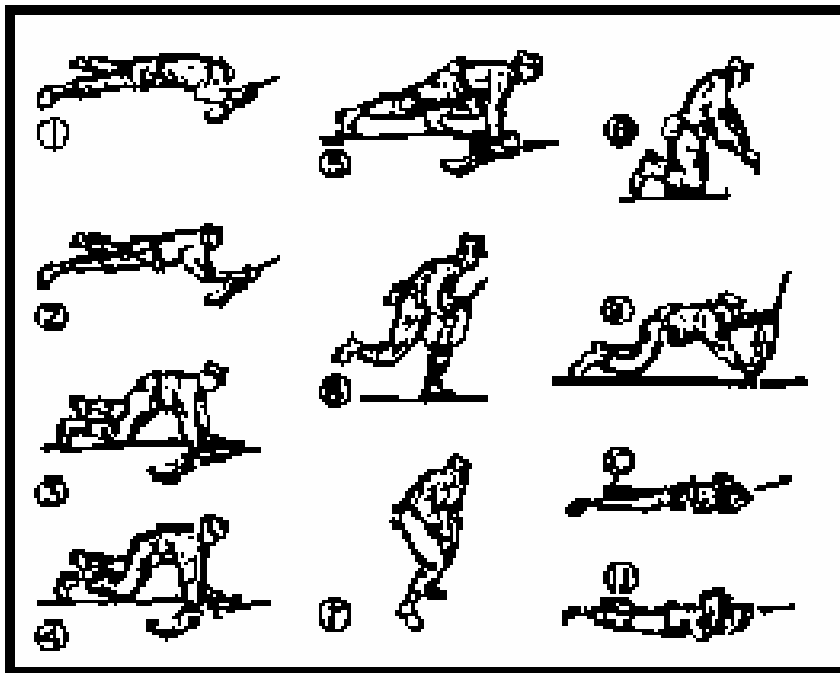

()

(

(

()

(

)

(

()

()

(

()

(

()

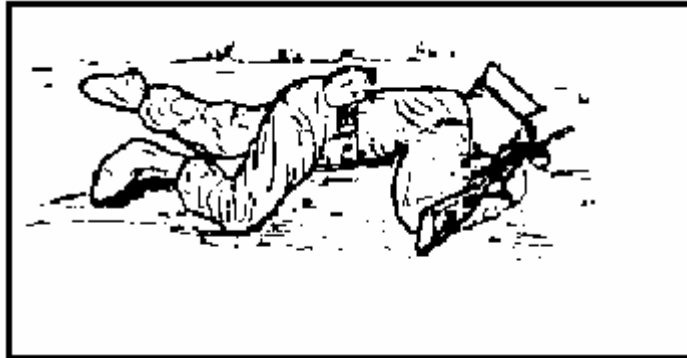

: (

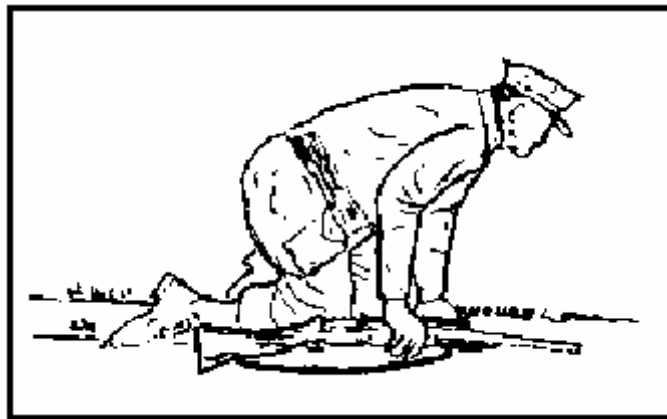

(:)

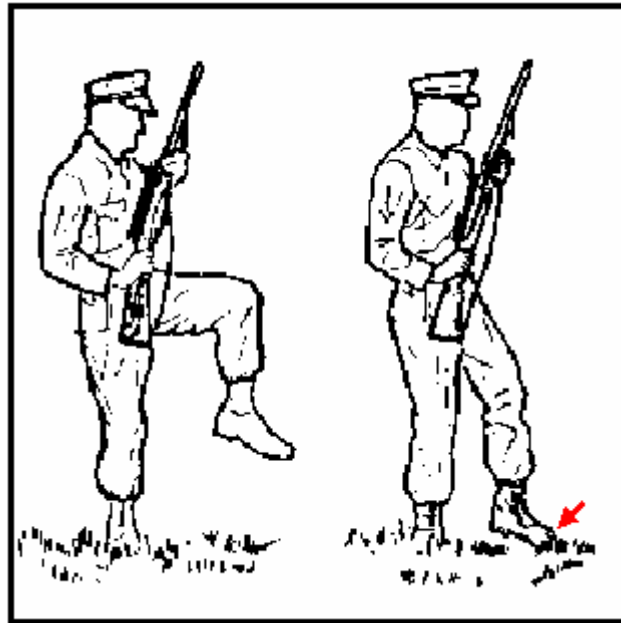

(:)

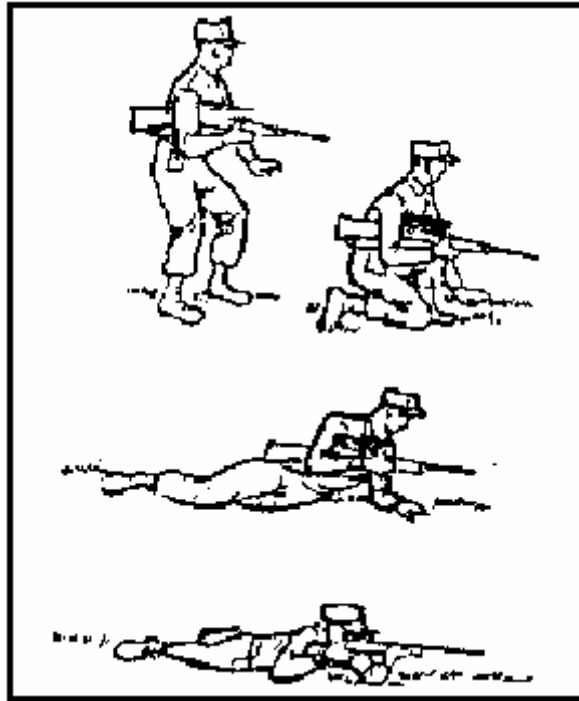

()

:

.

.

.

.

.

.

.

-

-

.

.

.

)

(

)

(

) (

)

(

) .()

() (

-

-

()

()

()

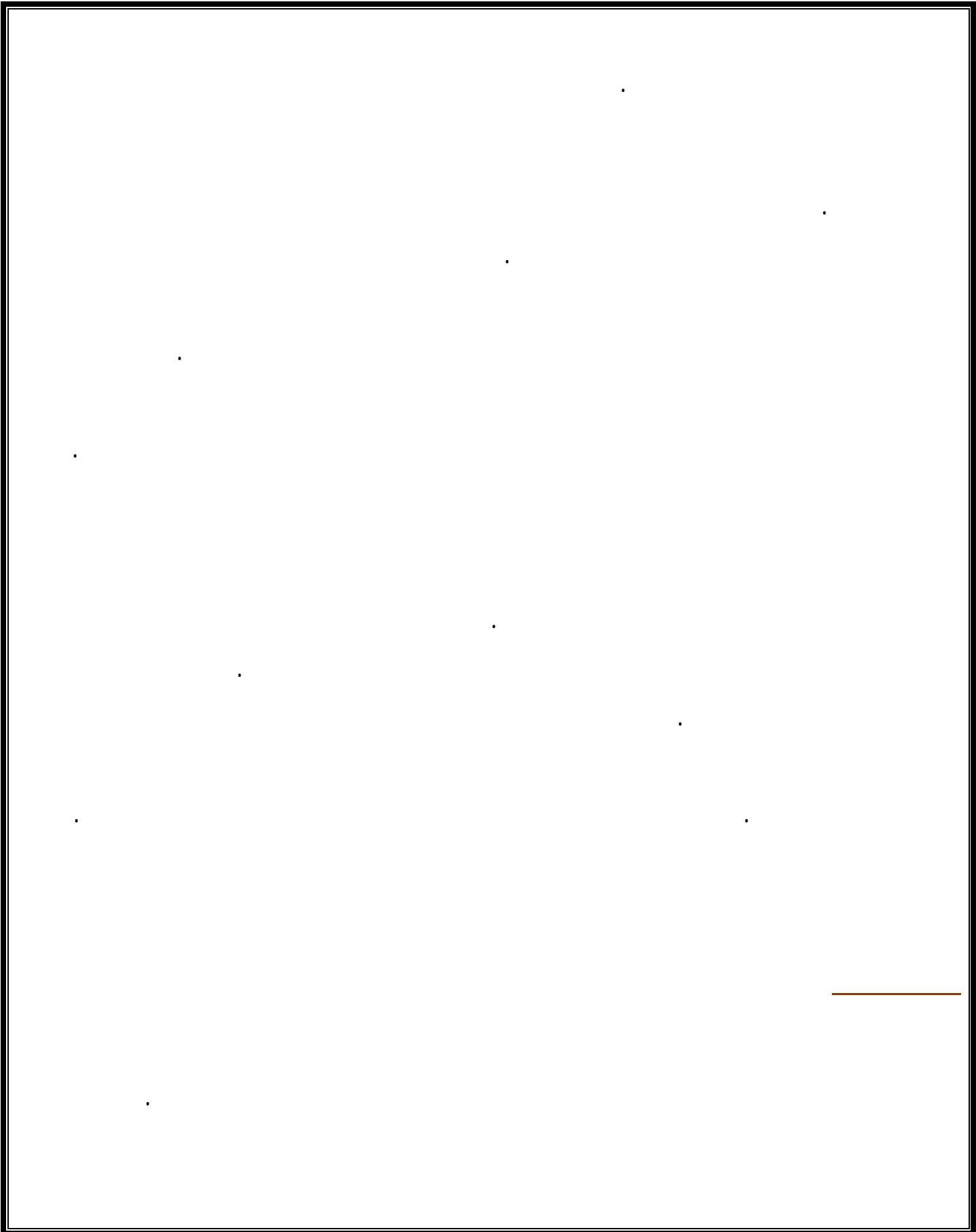

()

()

()

()

()

-

-

.

:

:

)

() (

()

()

()

)

()

(

..

{صفحة ناقصة في الأصل}

.

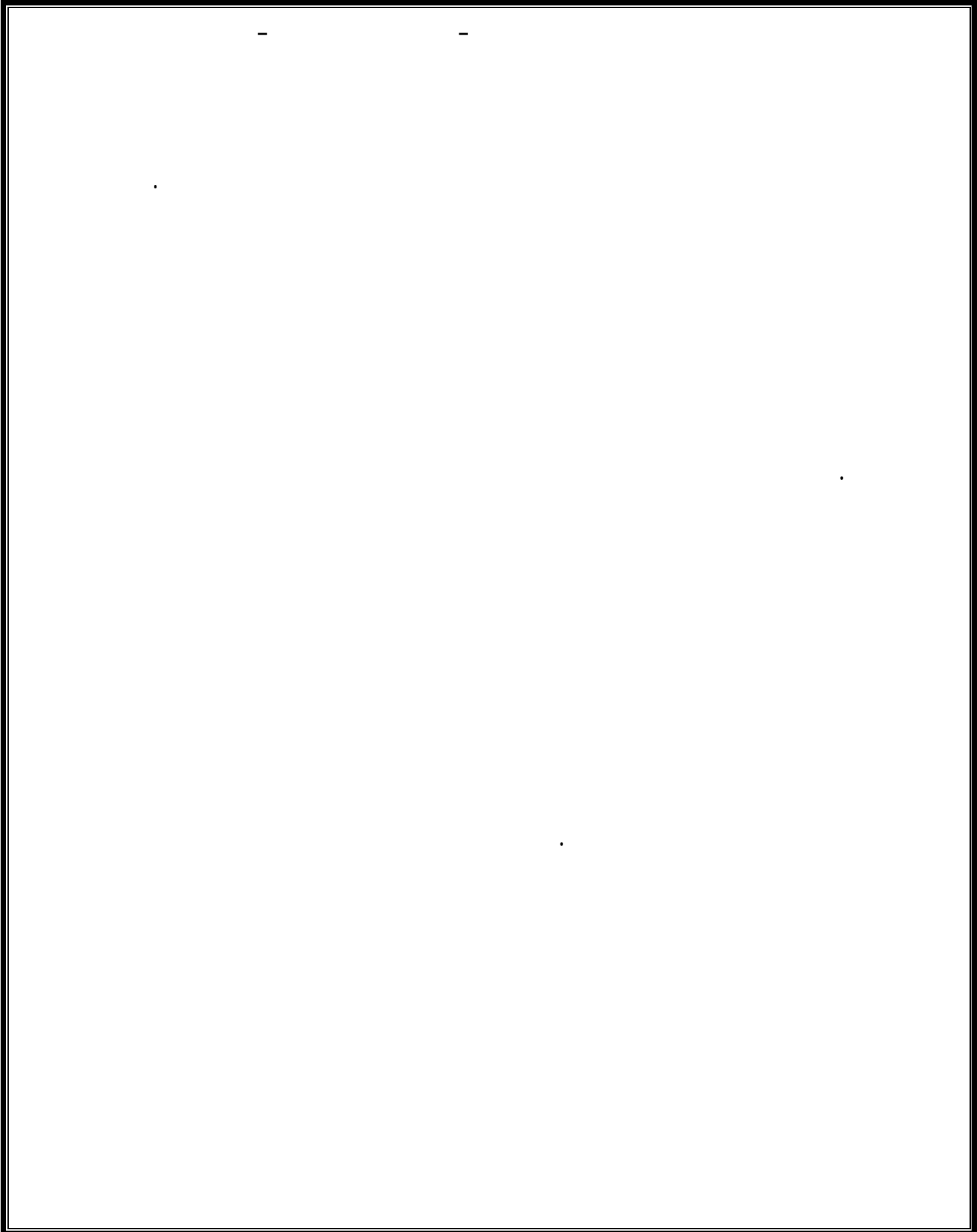

)

(

.

:

.

)

.(

.

()

()

(

()

(

(

(

(

(

(

(

(

(

(

(

(

(

(

(

.)

(

)

(
(
(
(
(
(
(
(
(

()

()

.()

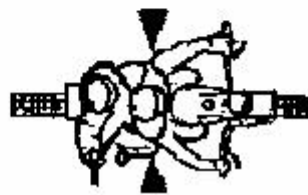
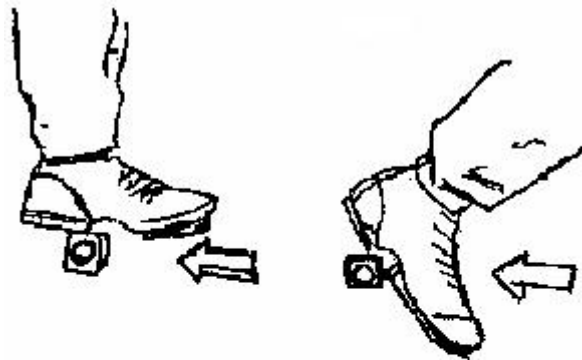

(

.() .

:

(

.()

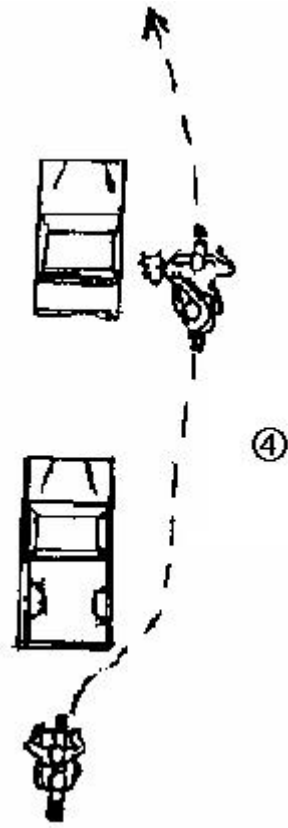
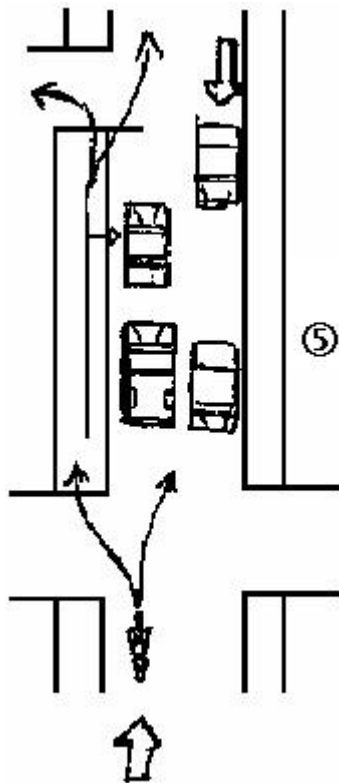

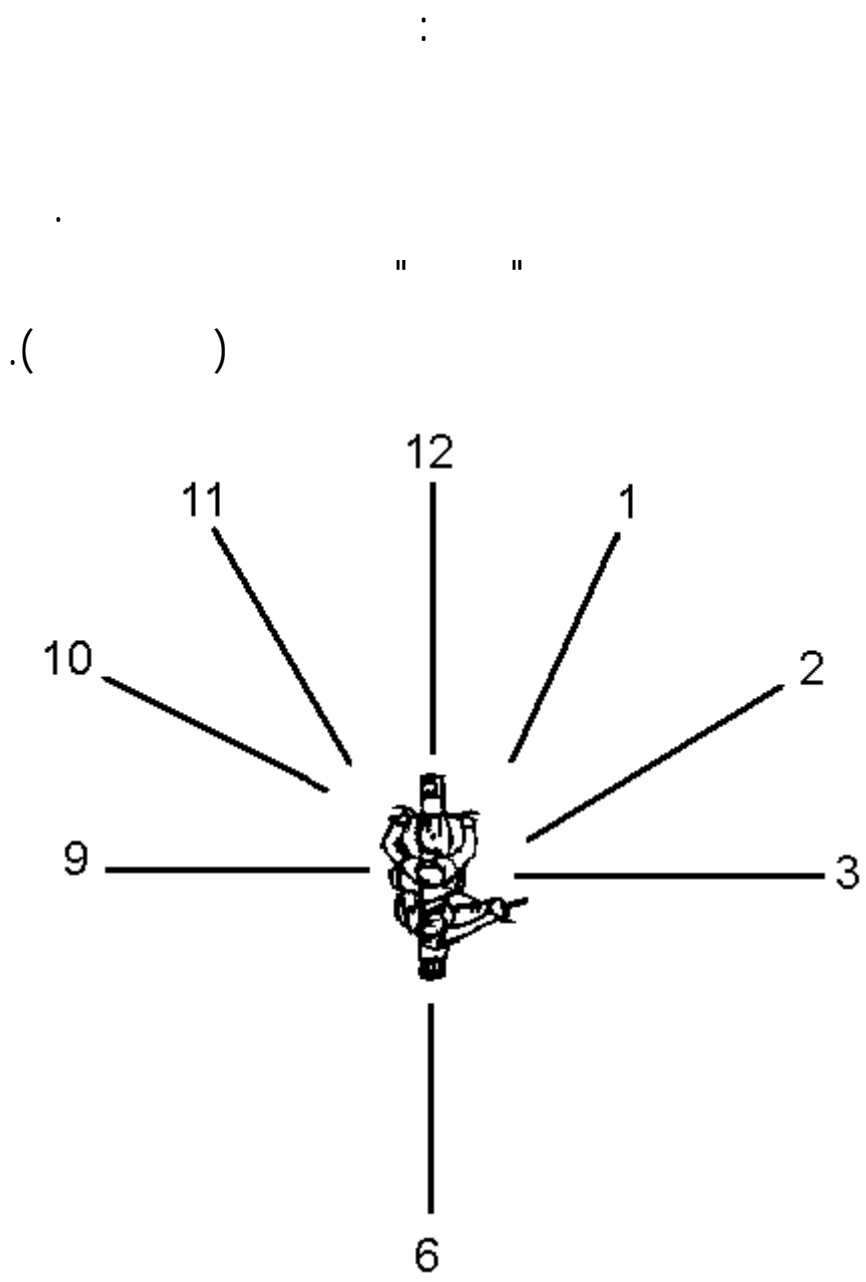

(

(

(

(

(

()

(

(

.() .

:

.()

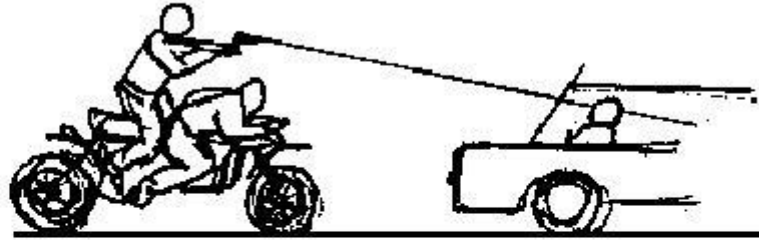
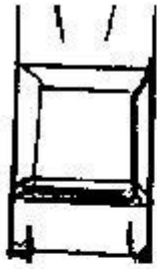

()

/

()

()

" "

()

.

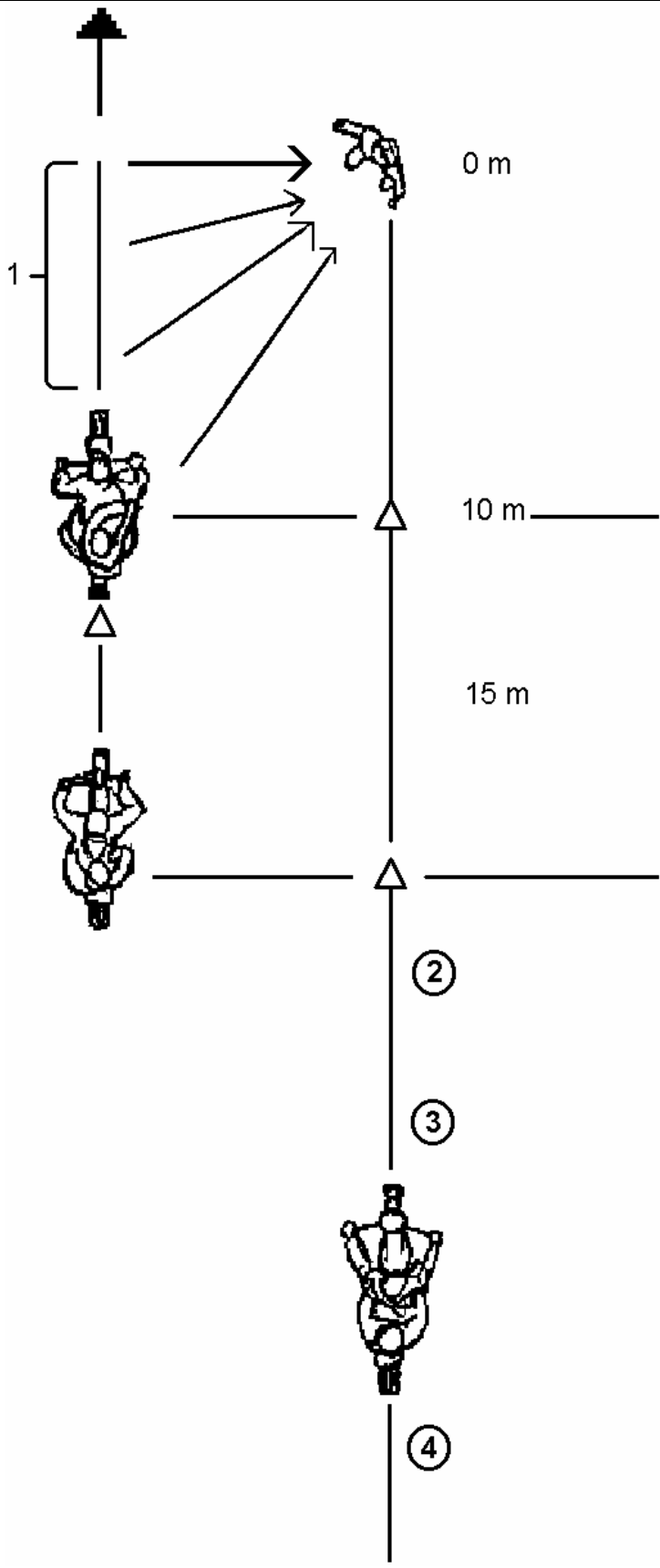

()

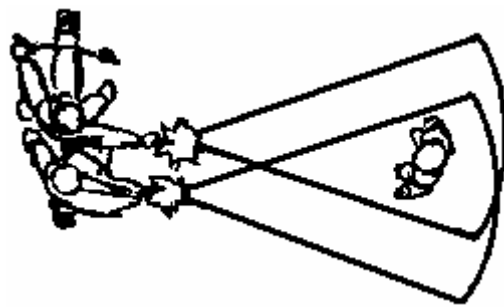
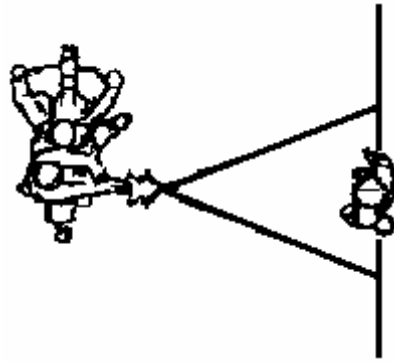

() ()

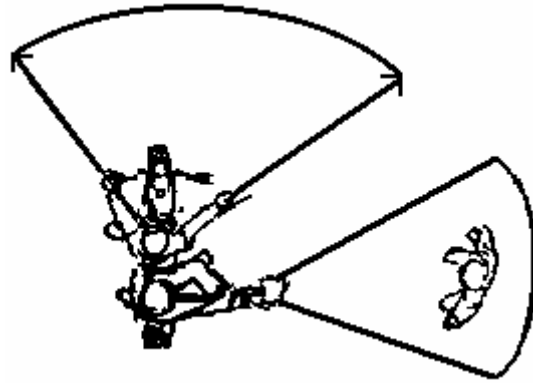

()

()

()

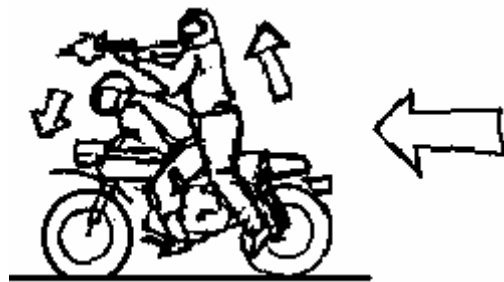

()

()

() .

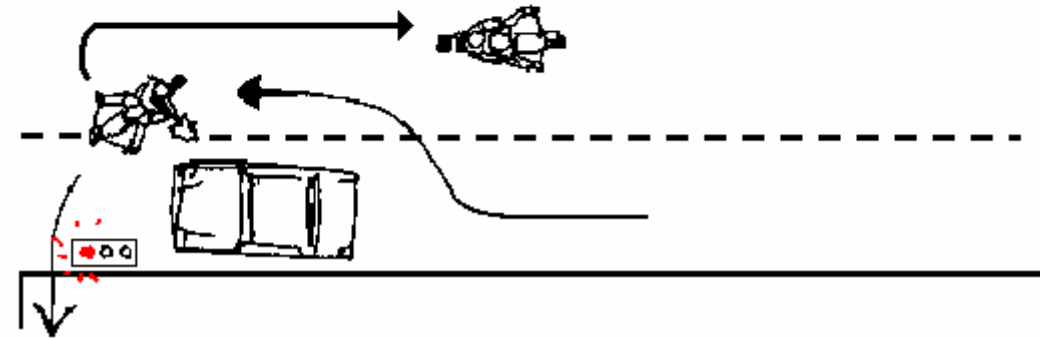
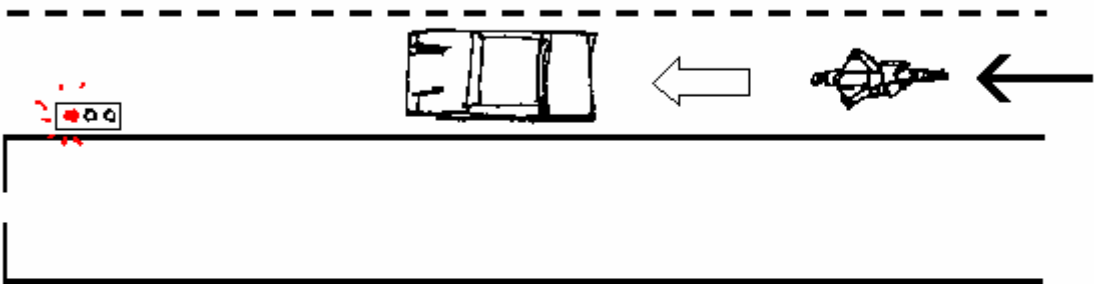

()

()

() .



①

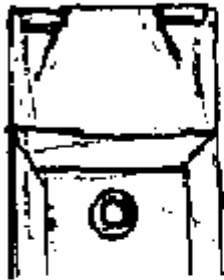

②

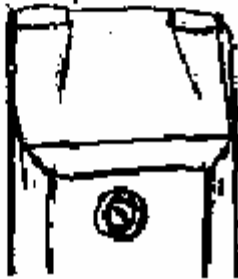

() .

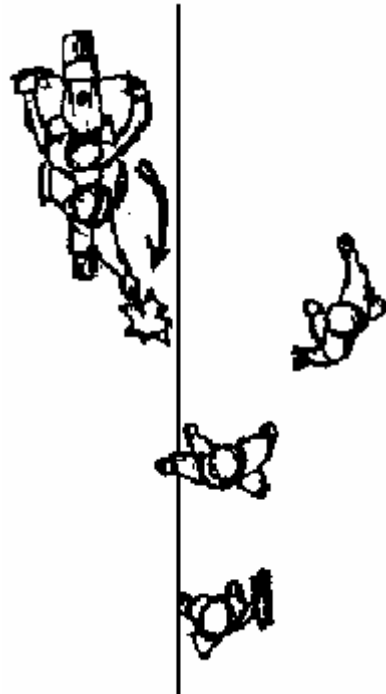

(

(

() .

(

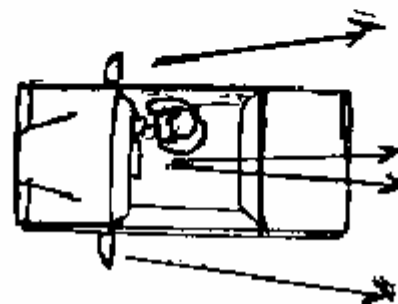
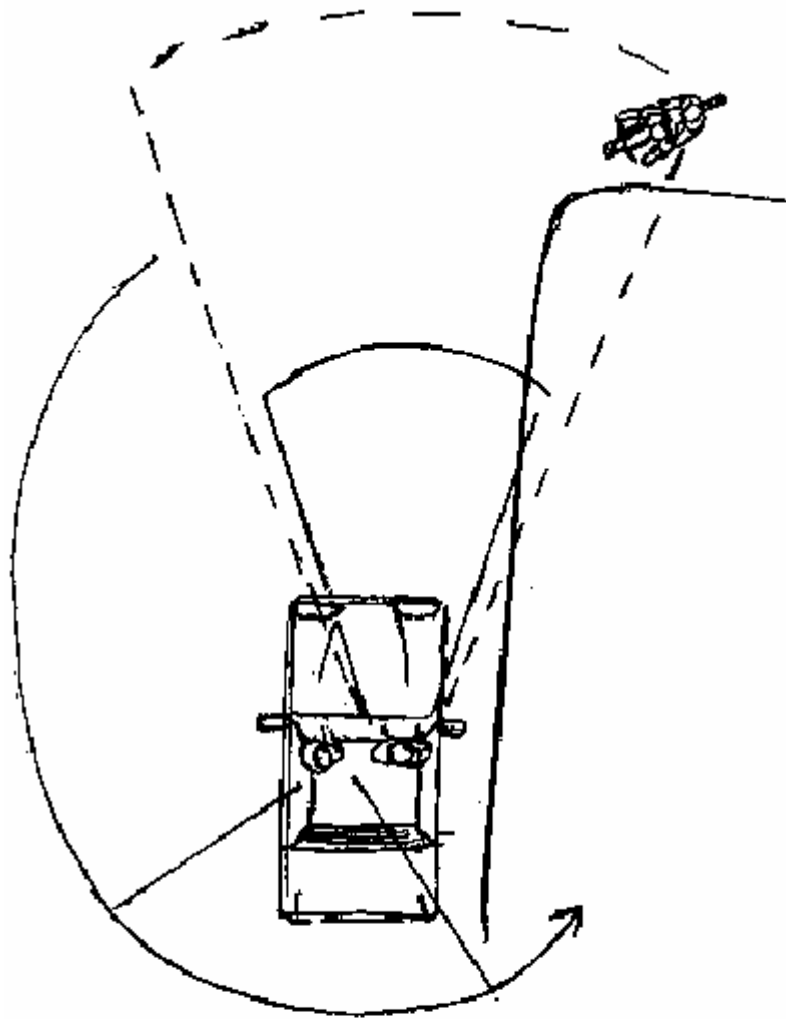

(

(

(

.()

(

(

(

()

:

:

()

.(()).

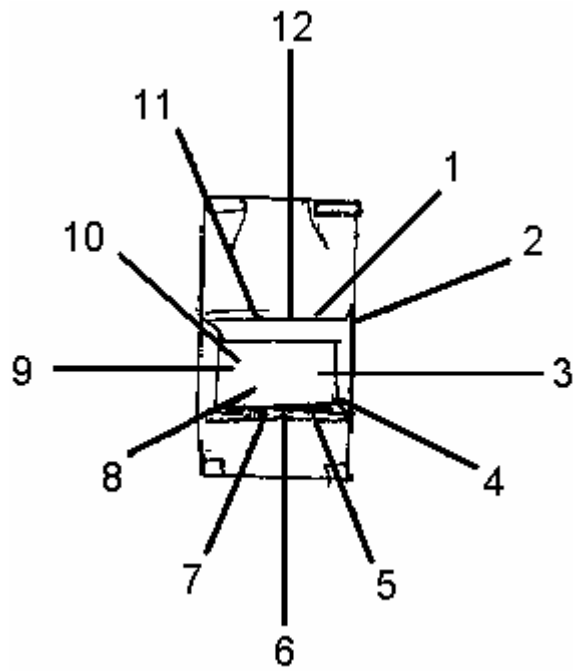

(

(

(

(

.() .

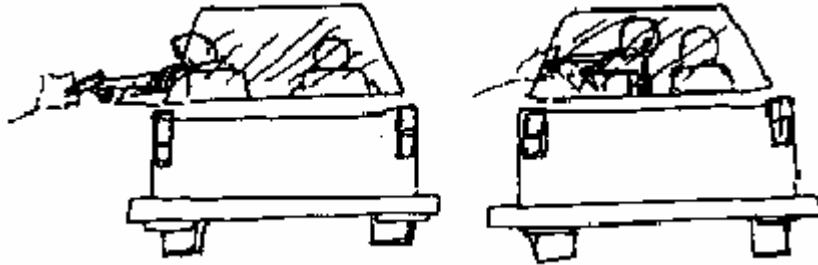

()
.()

.()

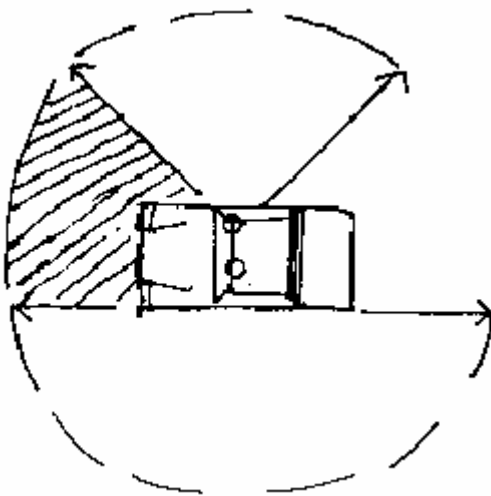

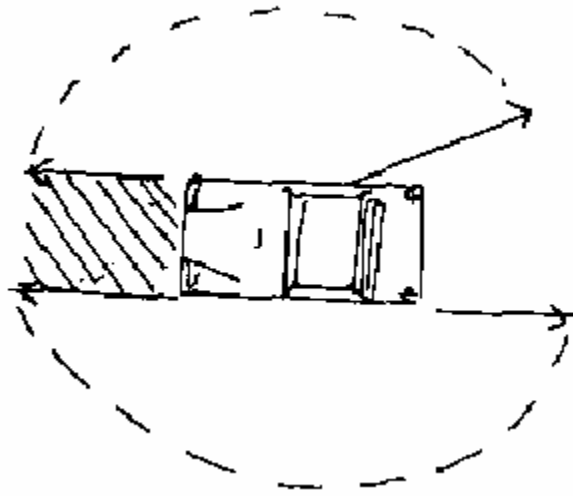

()

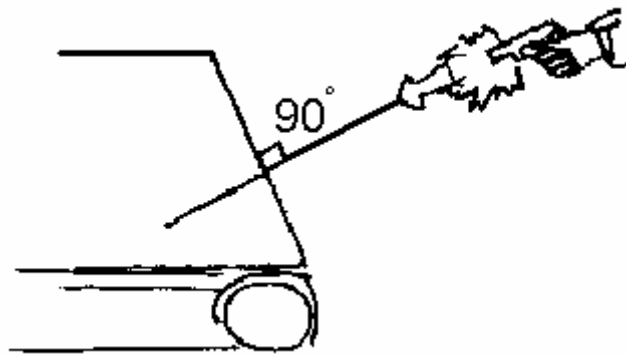

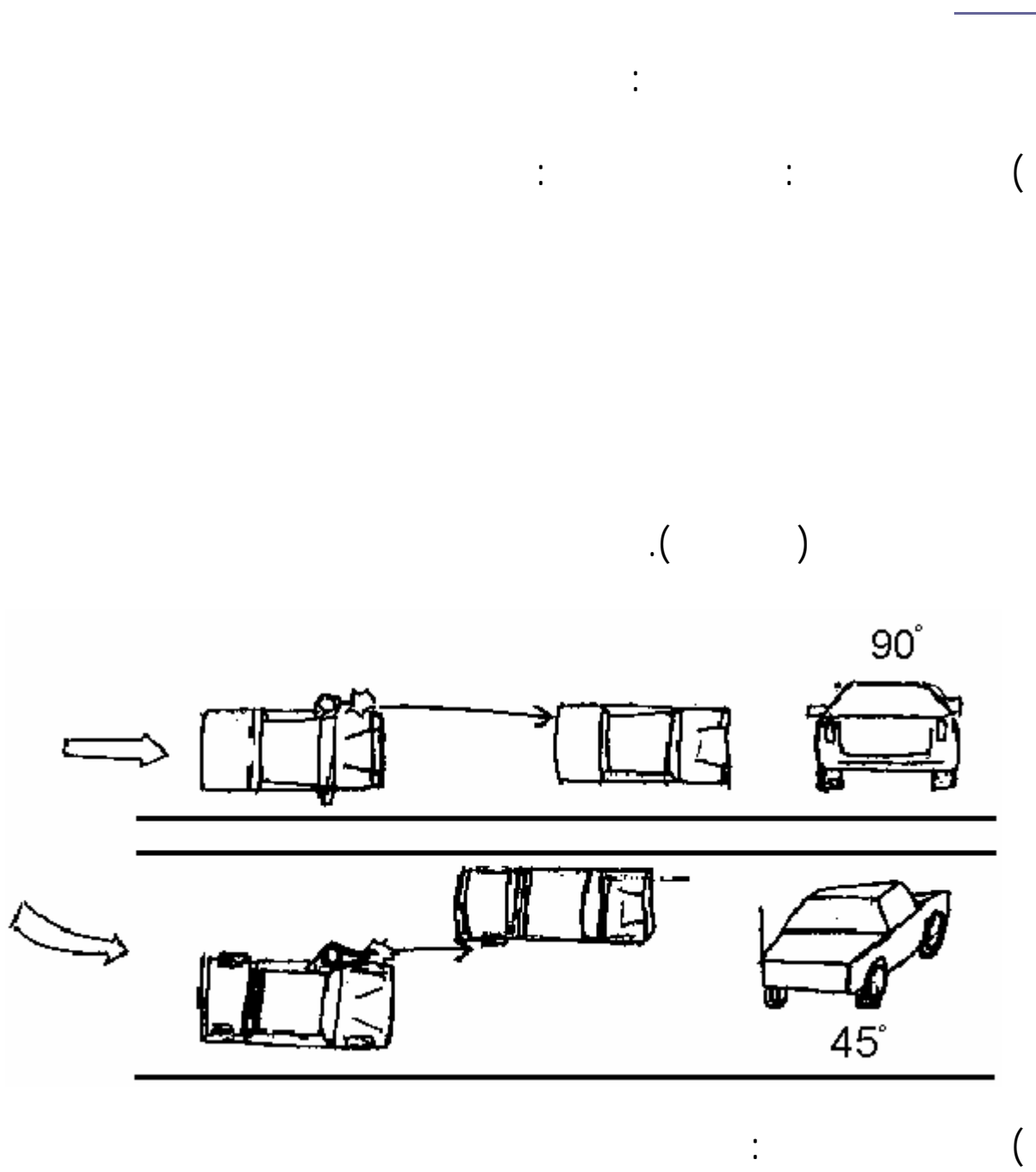

() .

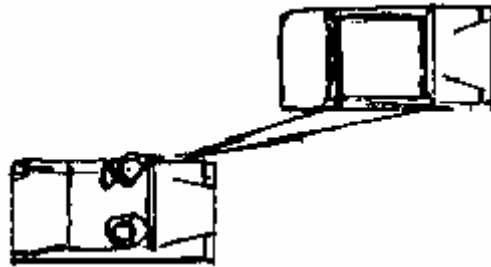
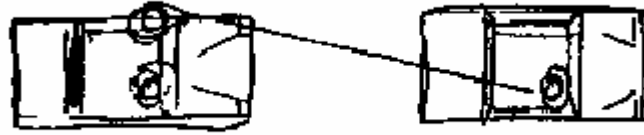

()

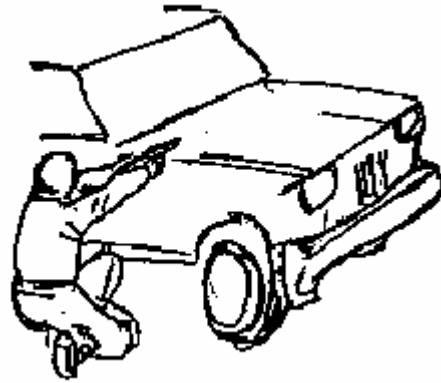
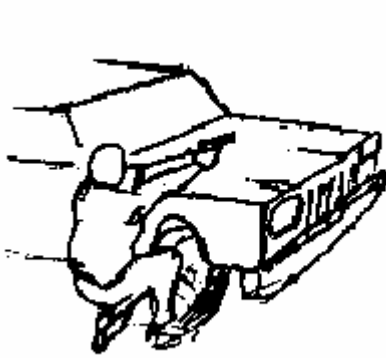

:

()

.()

:

.()

(
(

.()

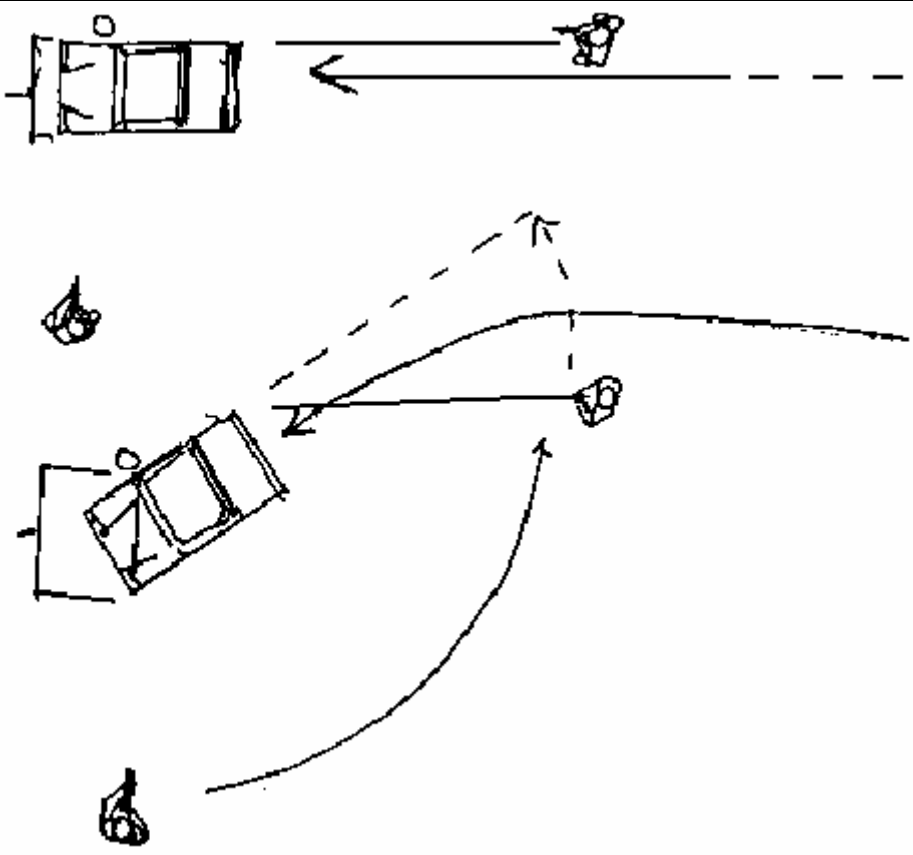

()

()

:

()

()

.()

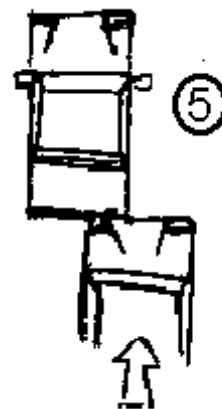
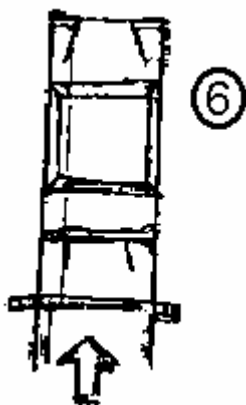
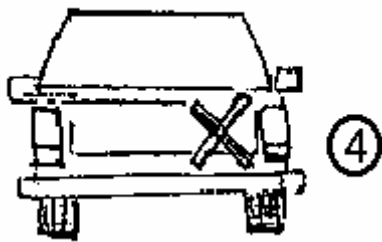
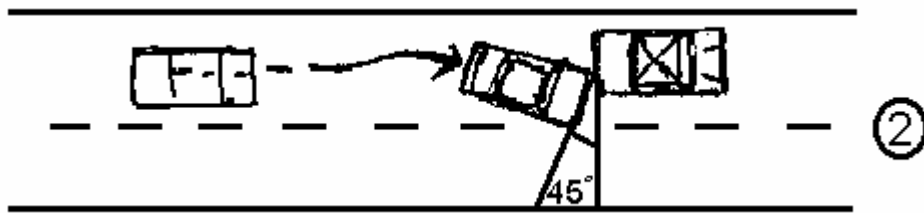
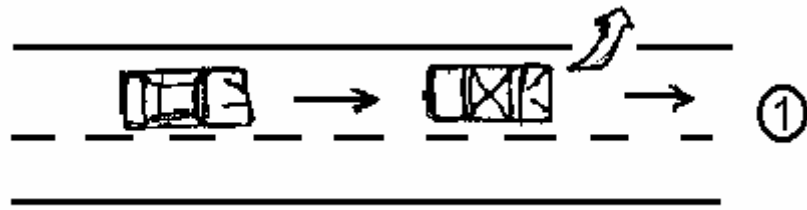

()

:

(

()

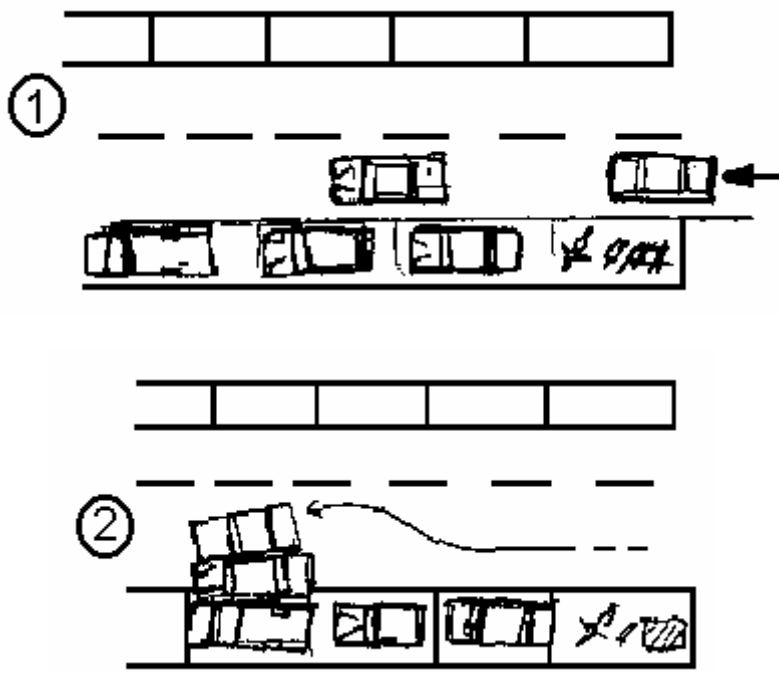

)

(

(

() .

()

:

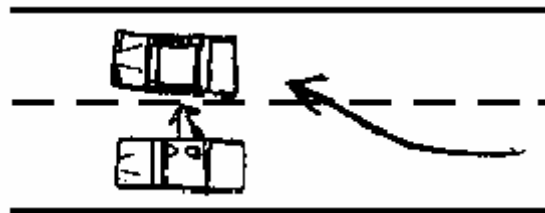
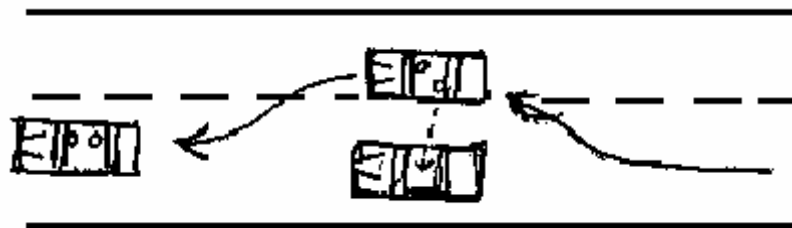

(
(
(

:

(

:

(

(

(

(

.()

()

.

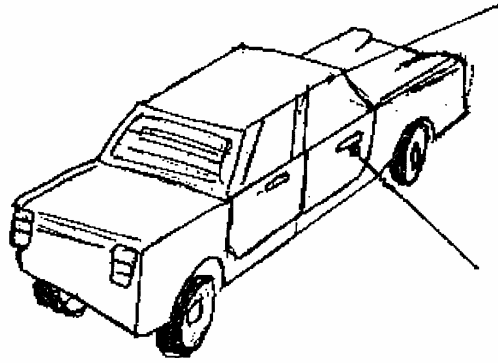

()

(

(

:

(

.()

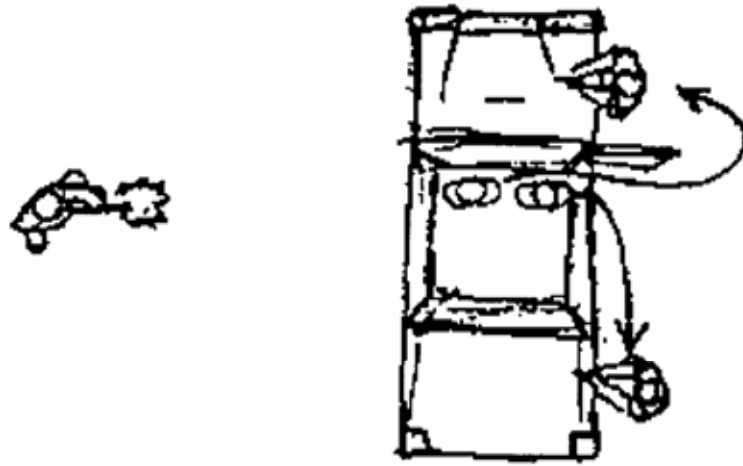

:

(

.()

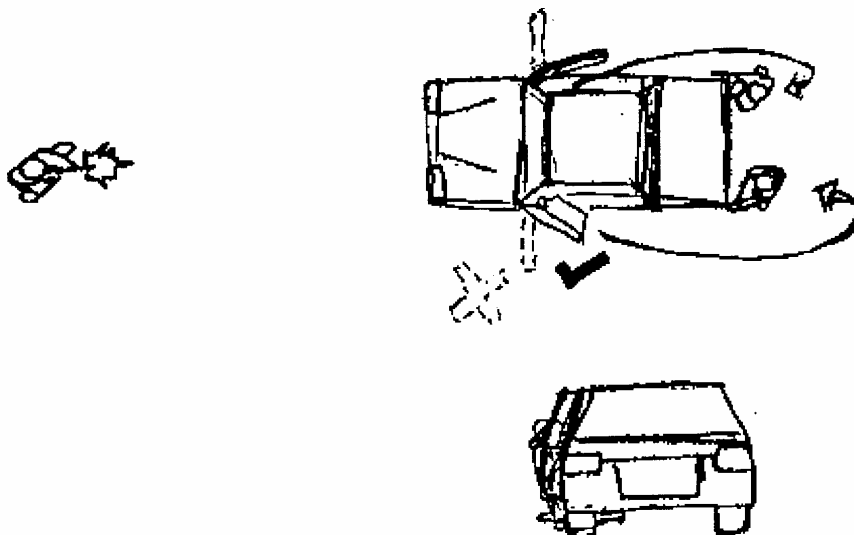

(:)

() .

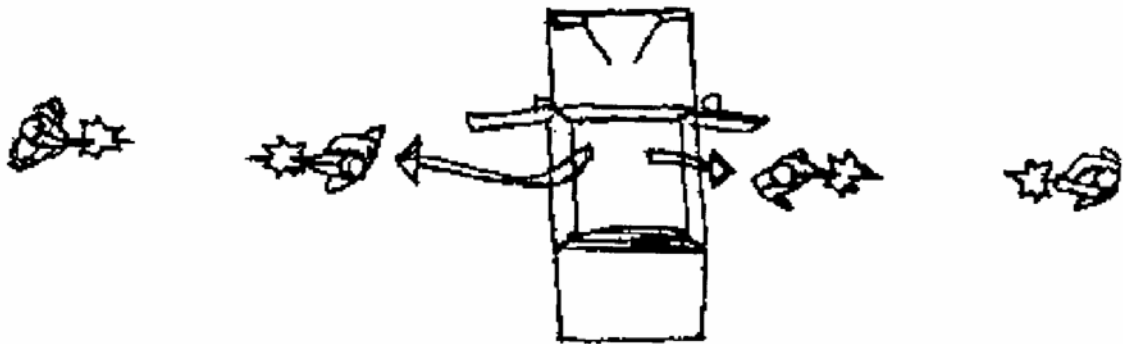

() .

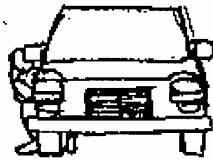
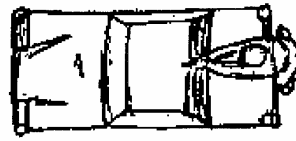
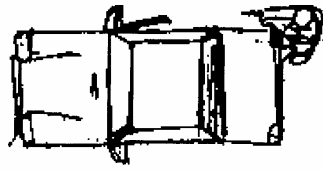

()

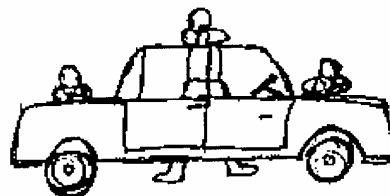
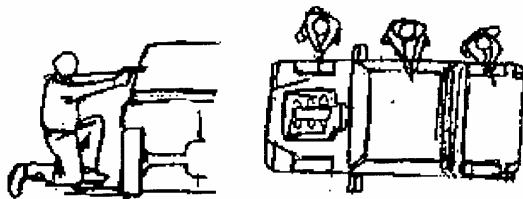

() .

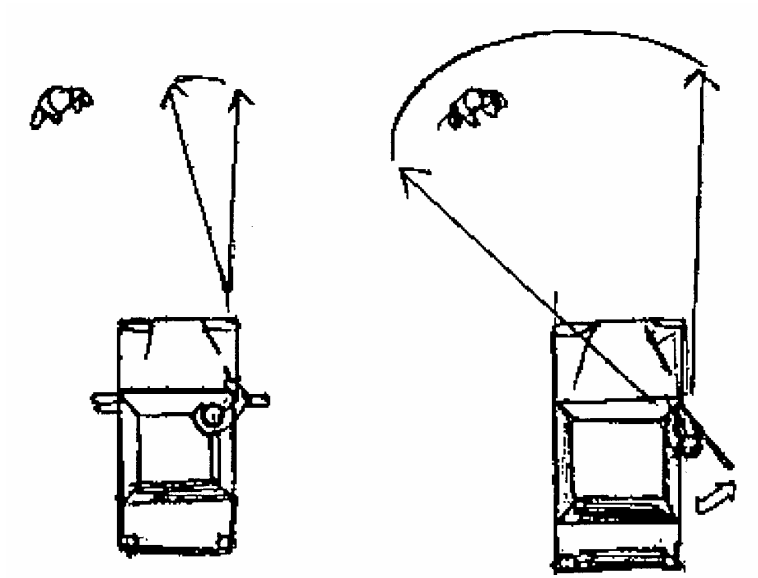

()

:

(

()

(

:

(

(

(

()

(

(

- ①
- ②
- ③
- ④
- ⑤

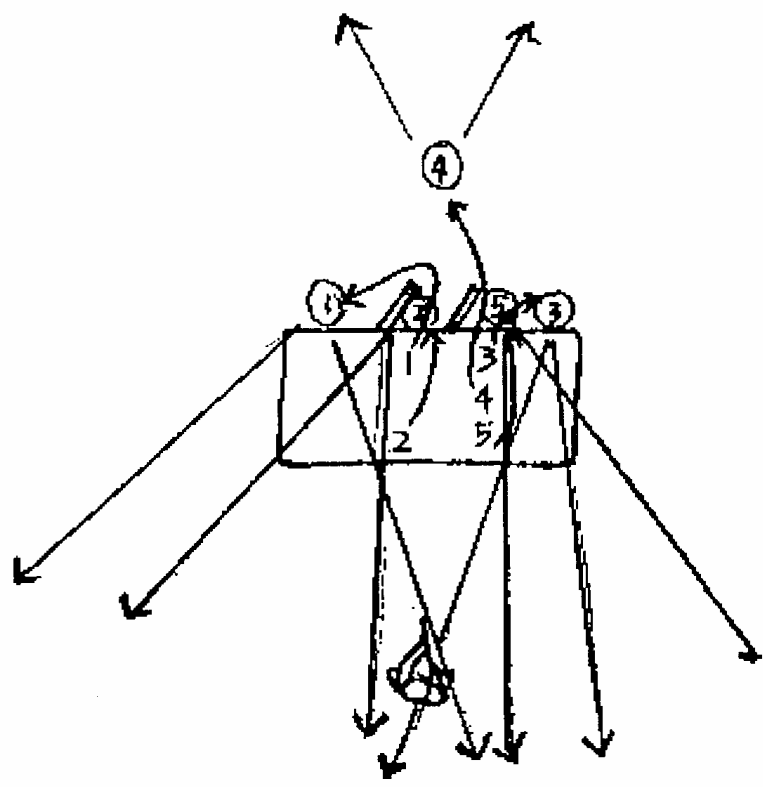

L

:

()

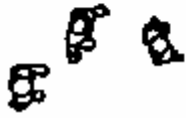
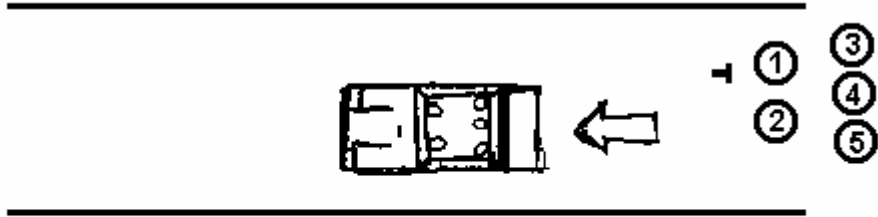

()

() ()

()

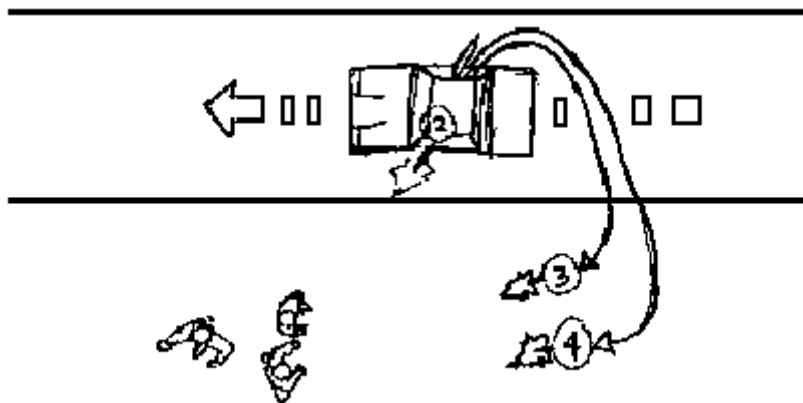

()

()

.()

()

()

()

.()

()

:

.

:

.

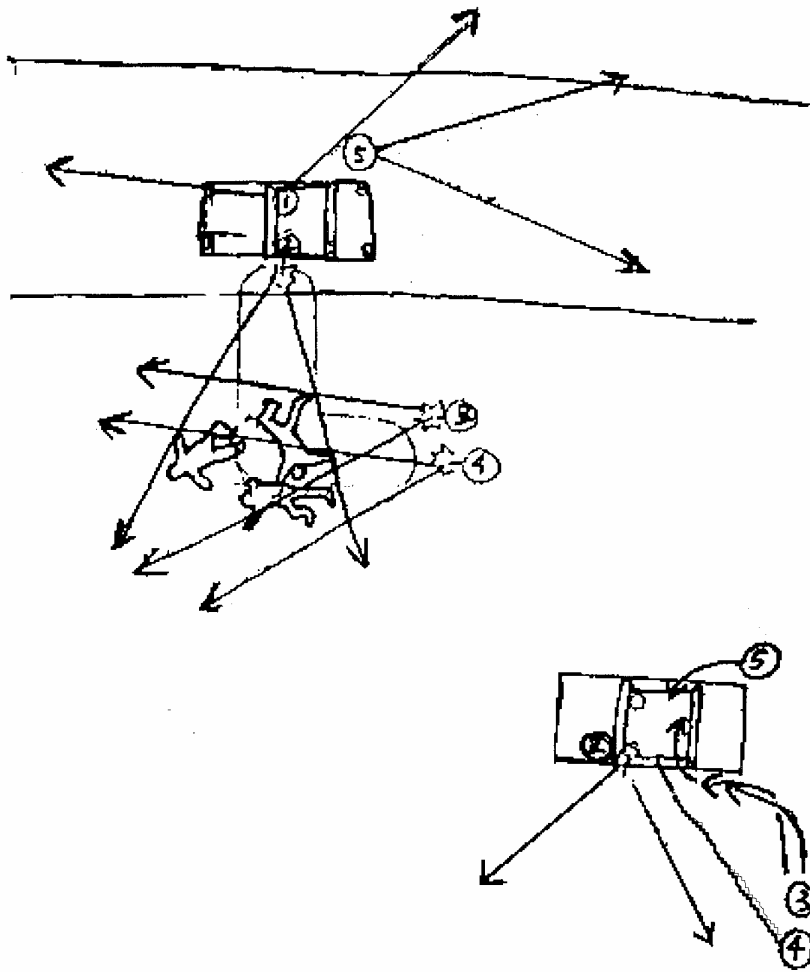

.()

.()

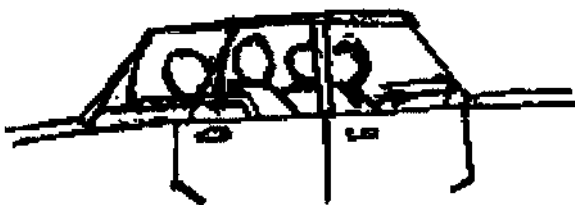
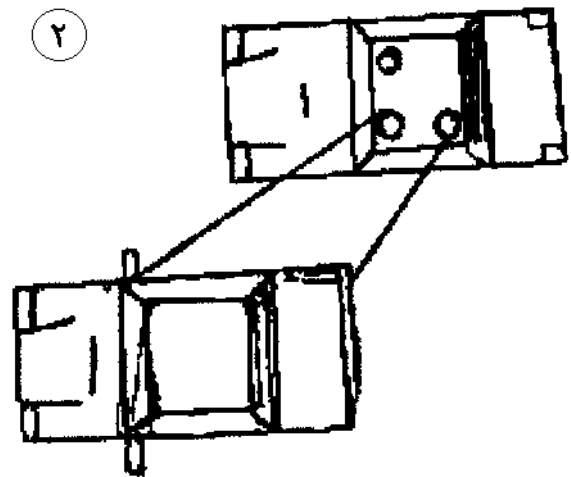
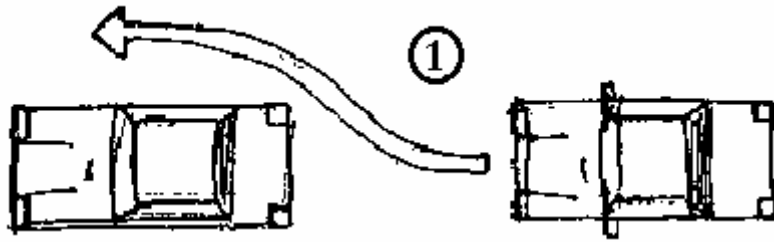

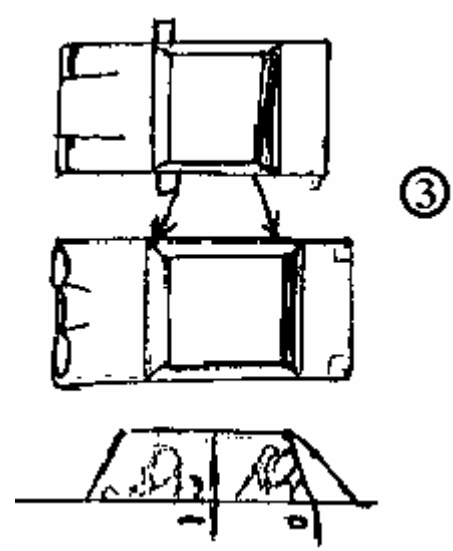
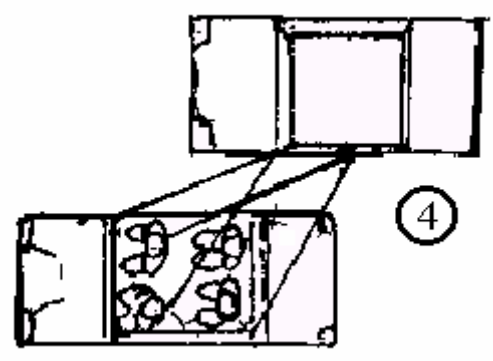
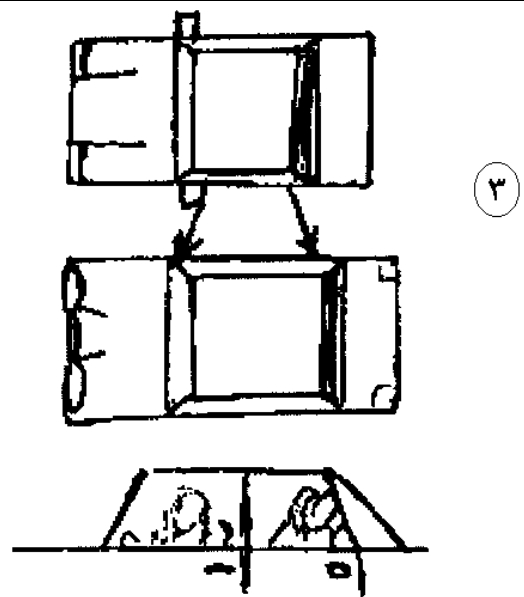
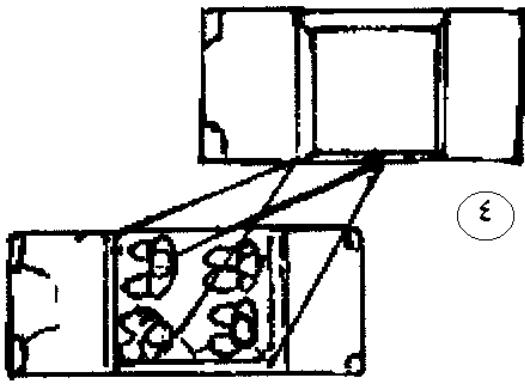

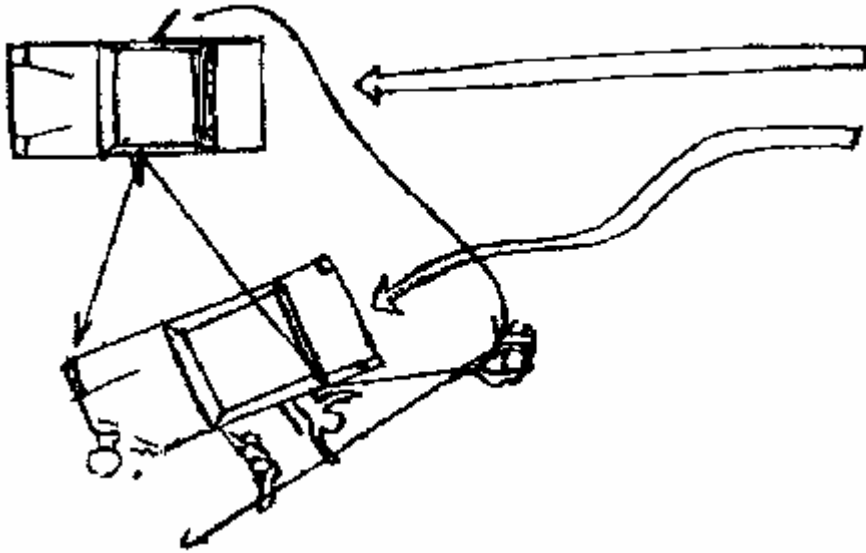

() ,

-
-
-

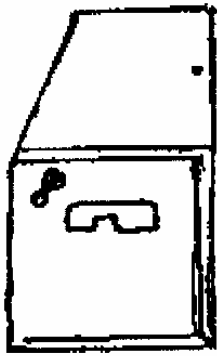

٢

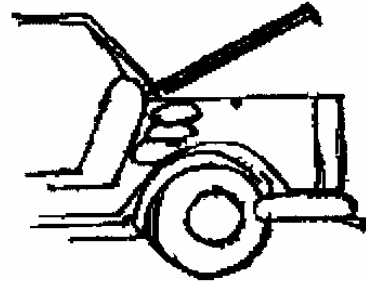
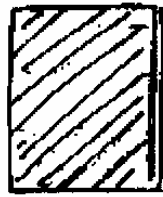

١

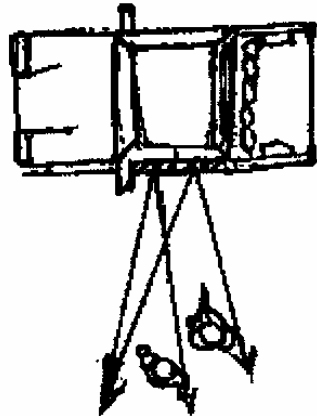

٣

· ()
· ()
· ()

.() ()
 .() . . . ()
 .() ()
 .() - - ()

.() ()
 .() ()
 .() ()

.() ()
 .() ()
 .() ()

()

:

▪

.

:

▪

” ”

(
(
(
(

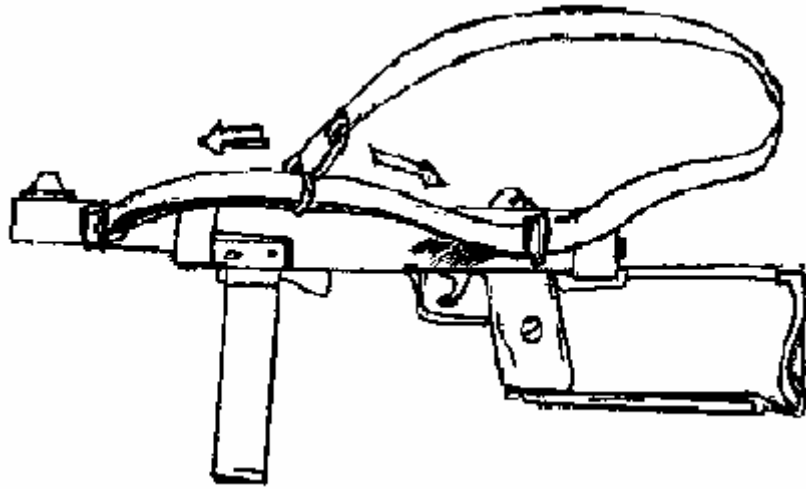

(

()



)

(

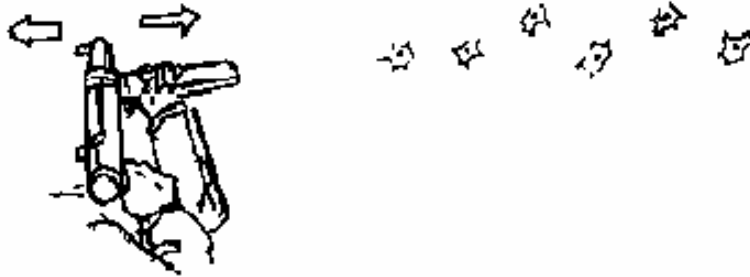

.)

(

()



()

(



(

.()

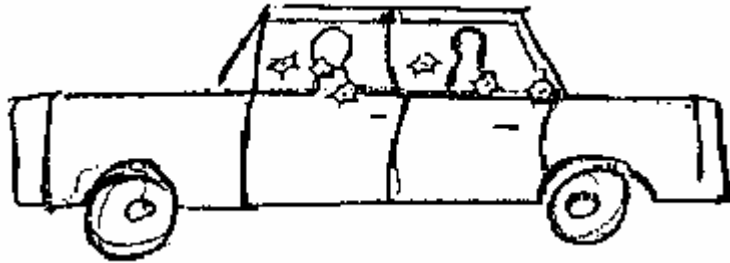

(

.() .

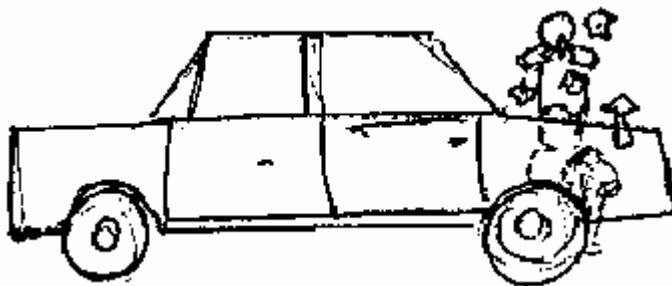

_____ (:

()

:

(

(

.()



()

: (

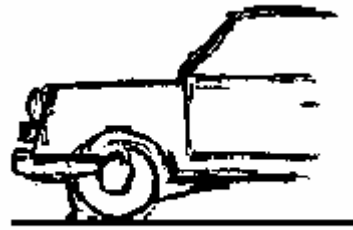
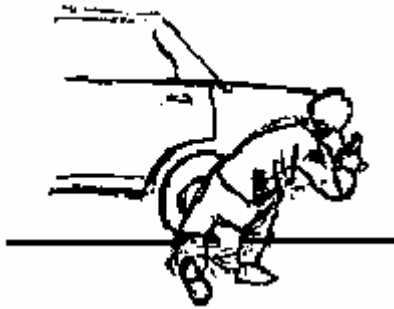



From M16A 24 inches sub-machine gun



From Elanfal /OW charging cell a cell instead of battery



AK 47 90 - 01V

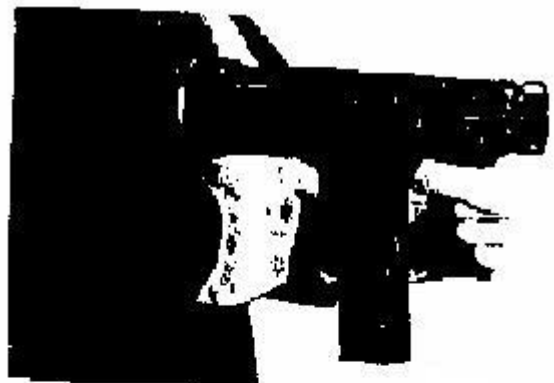

From Spectre M1. 4 sub-machine gun with bullet folder



Jeri-Matic sub-machine gun with round suppressor

:

(Code)

()

.()

: ()

(
(
(
(
(

()

()

:

:

.

:

.

."

."

:

.

:

(

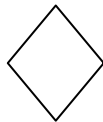

(

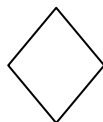

: (

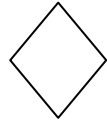

(-----)

)

(): :

.(

:
()

:

_____ +

.{()

()}

.

:

()

(

() =

()

.()

: ()
.

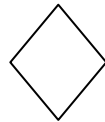

.

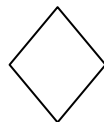
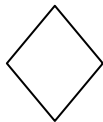

." " ←

:

” ”

(

(

:

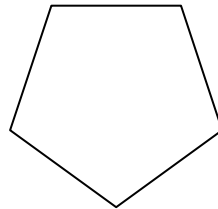
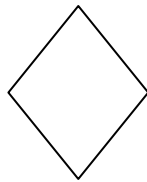

(

:

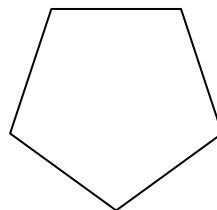
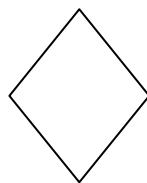

[() ()]

=(-) = (-)

.

() .

:

"

"

"

":

:

"

"

" "

(

(

(

(

(

(

"

"

:

(

(

. () RPG -

(

:

:

.(+)

)

.(

:

.()

()

(

.()

()

(

.() ()

(

(

:

▪

()

()

()

()

()

()

()

()

()

()

()

▪

.

_____ :

” ”

() () ▪

()
() ()
() () ()

() () () () ” ” ▪

) () () () () ()

.(

- - - - -) ▪

.(- -

: ▪

() ▪

:

_____ +
=

.() ▪

▪

.
 :
 () (= +) ()
 () () ()
 . ()
 :
 ()
 : ()
 : () :
 ————— -
 =
 () :
 () () () () ()
 () () () ()
 . " "

:(_____)

:
()

:" " ()
() () () () ()
:" ()
.() "

) ()
:(

:

(

)

.

-

.

” ”

.()

()

(

.()

()

(

.()

()

(

.()

()

(

.()

[() () () ()]

()

()

:

” ”

.(=) (=) (=) (=)

.()

()

” ”

:

(

:

” ”

:

.(=) (=) (=) (=)

.()

() (=)

.()

(=)(=)(=)()

:

)

.(

(

:

. ()

()

.(=)(=)(=)(=)

:

."

"

(=)(=)(=)(=)(=)(=) (

(=)(=)(=) (

(=)(=)(=)(=) (

(/ /):

(

)
 : ()
 : ()
 : () ()
 (, = ÷)
)
 .
 . ()
 .

()	()	()
()	()	()

(
 .() :
 .

()	()	()	()	()	()	
Y	∞	8	B	▽	△	

() ()
 () () () ()
 .(⚡) = = .(⚡ =)
 () ()
 : (....)

B	▽	△
Y	∞	⚡

()
 .
 : ()
 . " "

(=) (△) ()
 . (△ =)

	∞	Y	△	Y	∞	△	=
	△	B	△	∞	∞	△	=
△	B	△	△	∞	∞	△	=
		△	▽	△	△	∞	=

:

△ / △ B △ ∞ ∞ △ / ∞ Y △ Y ∞ △
 △ ▽ △ △ ∞ / △ B △ △ ∞ ∞

:() _____

." " :

			B	B	∞	△	=
∞	△	∞	△	△	∞	△	=
			△	▽	∞	∞	=
				▽	Y	∞	=

: ()

:()

”

”

=

▪

=

▪

=

▪

=

▪

/

/

/

):

(

:

()

()

:()

”

”

=

=

(

/

):

(

-
-

()

)

%

:

(

)

(

()

:

()

(

: () ()
 ()
 .() () ())
 . () ()
 = + = + () ()
 . () ()
 .() : () ()
 () ()
 ())
 :
 . → () ()
 . → (---) (---) ()
 . → = + ()
 . → = ()
 . → --- ()

:

$$.(A) \quad (X \quad Y)$$

$$.(\quad) () () = (Y) = (X) ($$

$$. = = (A) ()$$

: (

$$= - (-) = - (Y - A)$$

$$.() \quad () () = (Y)$$

: (

$$. = (A) (Y) :$$

$$. = = (A) = (Y)$$

$$.() ($$

: (

(

$$= + ($$

$$= ($$

$$. () () () ($$

:

(Y)

$$. (A)$$

(

()

()

.%

:

(

." " :

.(=)(=)(=)(=)

()

()

()

()

(

." " :

(

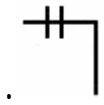

()

				2
				3
				4
				5
				6
				7
:		.		8

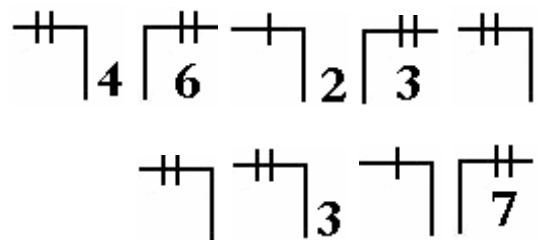

(

.) ()

:

(

(

(

:

(

(

:

(

(

()
(
(
(
:
:

(E,T,A,O,N,R,I,S)

/

(HE)

/

(TH)

(RE)

(AN)

() :

()

)

(

.(

(

(

(

.()

(

(

(

(

(

(

قربحمد الله

مع تحيات إخوانكم

أنصار الجهاد

فلا تنسوهم من دعائكم

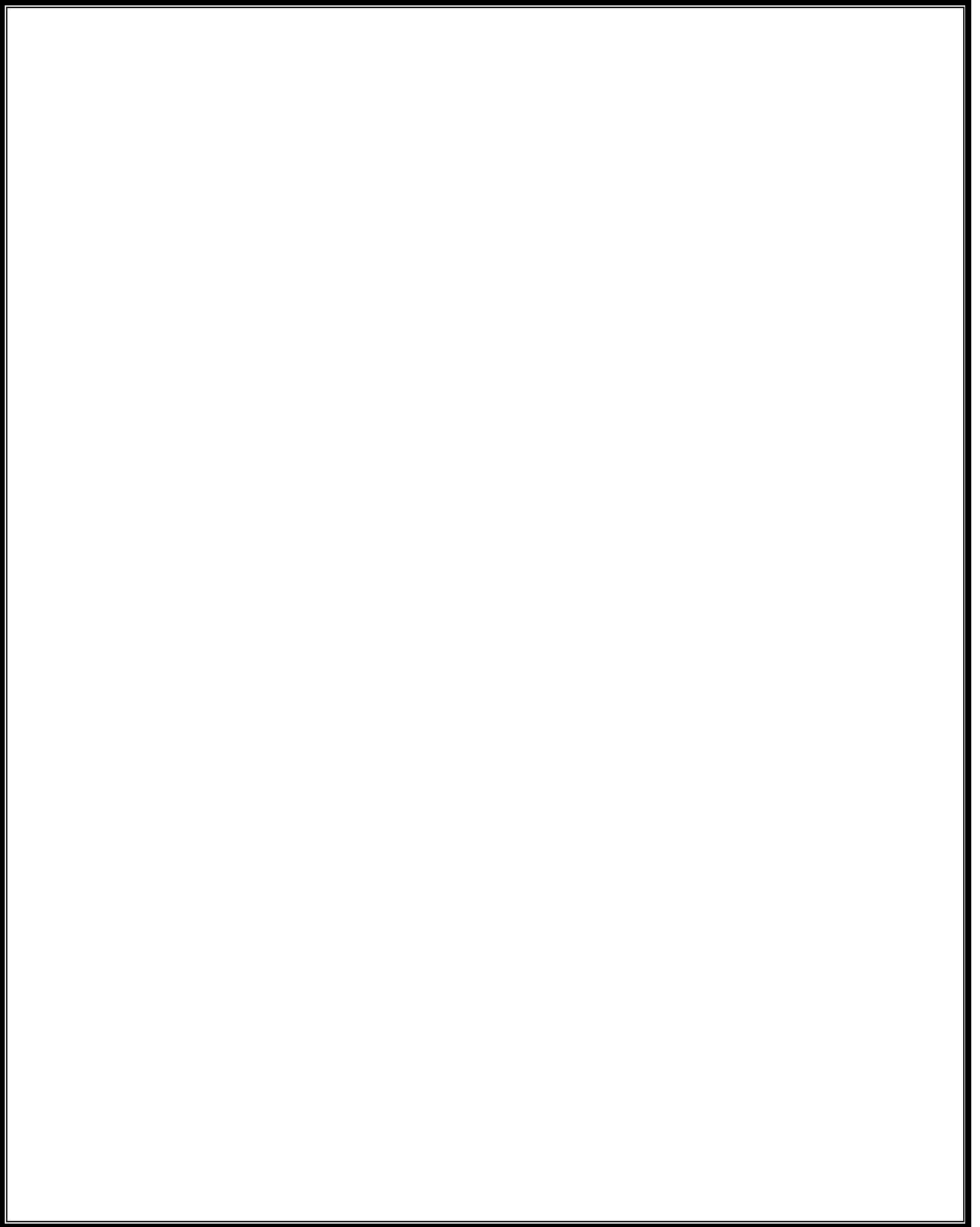

(

(

-----D.M.S.O

----- ()

(

(

(

(

(

-----Disk Tumbler Locks (

----- ()

----- ()

----- ()

----- ()

----- " "-----

----- (Code)

تربحمد الله